



**CITY OF WHARTON
CITY COUNCIL REGULAR MEETING**

**Monday, June 27, 2022
7:00 PM**

***CITY HALL 120 EAST CANEY STREET
WHARTON, TEXAS 77488***

**NOTICE OF
CITY OF WHARTON
CITY COUNCIL REGULAR MEETING**

Notice is hereby given that a City Council Regular Meeting will be held on Monday, June 27, 2022 at 7:00 PM at the Wharton City Hall, 120 East Caney Street, Wharton, Texas, at which time the following subjects will be discussed to-wit:

SEE ATTACHED AGENDA

Dated this 23rd day of June 2022.

By: 
Tim Barker, Mayor

I, the undersigned authority, do hereby certify that the above Notice of Meeting of the City Council Regular Meeting is a true and correct copy of said Notice and that I posted a true and correct copy of said Notice on the bulletin board, at City Hall of said City or Town in Wharton, Texas, a place convenient and readily accessible to the general public at all times, and said Notice was posted on June 23, 2022, at 4:30 p.m. and remained so posted continuously for at least 72 hours preceding the scheduled time of said Meeting.

The Wharton City Hall is wheelchair accessible. Access to the building and special parking is available at the primary entrance. Persons with disabilities, who plan to attend this meeting and who may need auxiliary aids or services such as interpreters for persons who are deaf or hearing impaired, readers, or large print, are requested to contact the City Secretary's Office at (979) 532-4811 Ext. 225 or by FAX (979) 532-0181 at least two (2) days prior to the meeting date. BRAILLE IS NOT AVAILABLE.

Dated this 23rd day of June 2022.

CITY OF WHARTON

By: 
Paula Favors
City Secretary



A G E N D A
CITY OF WHARTON
City Council Regular Meeting
Monday, June 27, 2022
City Hall - 7:00 PM

Call to Order –Opening Devotion –Pledge of Allegiance.

Roll Call and Excused Absences.

Public Comments.

Wharton Moment.

Review and Consider:

1. City of Wharton Financial Report for April 2022.
2. Utility Easement Agreements:
 - A. Resolution: A resolution of the Wharton City Council accepting a Utility Easement Agreement between the City of Wharton and Russell J. Baird for William Kincheloe League, Abstract No. 38, Wharton County, Texas, Block 1, Lot 3, 4, 5 & 6, of the Baird Subdivision and authorizing the Mayor of the City of Wharton to execute said agreement.
 - B. Resolution: A resolution of the Wharton City Council accepting a Utility Easement Agreement between the City of Wharton and Justin D. & Kristina D. Crouch for William Kincheloe League, Abstract No. 38, Wharton County, Texas, Block 1, Lot 1 & 2, of the Baird Subdivision and authorizing the Mayor of the City of Wharton to execute said agreement.
3. Request from The Brooks at Caney Creek for sidewalk replacement on North Richmond Road.
4. Wharton Economic Development Corporation Fiscal Year 2022-2023 Annual Budget.
5. Resolution: A resolution of the Wharton City Council approving an additional three (3) months on the MyGov, LLC Software for the City of Wharton and authorizing the Mayor of the City of Wharton to execute all documents related to said contract.
6. Resolution: A resolution of the Wharton City Council authorizing the submission of applications to the Texas Department of Emergency Management under the Hazard Mitigation Grant Program – Texas COVID-19 Pandemic DR-4485 on behalf of Wharton Independent School District, entering into a Memorandum of Understanding and authorizing the Mayor to execute all documents relating to said applications and Memorandum of Understanding.
7. Resolution: A resolution of the Wharton City Council ratifying a Facilities Extension Agreement with CenterPoint Energy for Utility Service on C.R. 222 for the Wharton Water Well Project and authorizing the Mayor of the City of Wharton to execute the agreement.

- [8.](#) Resolution: A resolution of the Wharton City Council approving an Encroachment Agreement with W. A. Harrison Agriculture, LTD., for a fence encroachment on Tract 224 of the Wharton Levee Project; and authorizing the Mayor of the City of Wharton to execute said agreement.
- [9.](#) Resolution: A resolution of the Wharton City Council authorizing and approving Change Order No. 2 with Arandas Industries for the Wharton Colorado River Flood Control Public Utility Abandonment – Hughes Street and authorizing the Mayor to execute all documents related to said Change Order.
- [10.](#) Resolution: A resolution of the Wharton City Council authorizing and approving Change Order No. 3 with Arandas Industries for the Wharton Colorado River Flood Control Public Utility Abandonment – Hughes Street and authorizing the Mayor to execute all documents related to said Change Order.
- [11.](#) Resolution: A resolution of the Wharton City Council approving Change Order No. 5 due to cost increases due to roof fan model changes with E Contractors for the Wharton Well and Water Plant Project and authorizing the Mayor to execute all documents related to said change order.
- [12.](#) Pay Request No. 5 from E-Contractors for the Wharton Well and Water Plant Contract No. 1 – General Construction.
- [13.](#) Pay Request No. 5 and 5a, from Weisinger Inc. for the Wharton Well and Water Plant Contract No. 2 – Well Construction.
- [14.](#) Resolution: A resolution of the Wharton City Council approving the dissolution of the City of Wharton Housing Finance Corporation; authorizing the preparation and execution of all documents necessary to dissolve the corporation; and authorizing the Mayor of the City of Wharton to execute all documents related to the dissolution.
- [15.](#) Update of City of Wharton Grant Programs.
- [16.](#) Update of City of Wharton on-going Projects.
- [17.](#) Appointments, Resignations and Vacancies to the City of Wharton Boards, Commissions and Committees:
 - A. Appointments.
 - B. Resignations.
 - C. Vacancies.
- [18.](#) City Council Boards, Commissions and Committee Reports:
 - A. Finance Committee meeting held June 13, 2022.
- [19.](#) City Manager’s Reports:
 - A. City Secretary/Personnel.
 - B. Code Enforcement.
 - C. Community Services Department/Civic Center.

- D. Emergency Management.
- E. E. M. S. Department.
- F. Facilities Maintenance Department/Wharton Municipal Pool.
- G. Fire Department.
- H. Fire Marshal.
- I. Legal Department.
- J. Municipal Court.
- K. Police Department.
- L. Public Works Department.
- M. Water/Sewer Department.
- N. Weedy Lots/Sign Ordinance.
- O. Wharton Regional Airport.

Executive Session:

20. City Council may adjourn into an Executive Session in accordance with Sections 551.074 of the Local Government Code, Revised Civil Statutes of Texas. Final action, decision or vote, if any with regard to any matter considered in Executive Session shall be made in Open Meeting.

Discussion:

- A. City Managers Evaluation.

Return to Open Session:

21. Action on items discussed in Executive Session:
- A. City Managers Evaluation.

Adjournment.

City of Wharton
 120 E. Caney Street
 Wharton, TX 77488

CITY COUNCIL COMMUNICATION

Meeting Date:	5/23/2022	Agenda Item:	City of Wharton Financial Report for April 2022.
<p>Attached you will find a copy of the City of Wharton Financial Report for the month of April 2022.</p> <p>Finance Director, Joan Andel, will present the report.</p>			
City Manager: Joseph R. Pace		Date: Thursday, May 19, 2022	
Approval: 			
Mayor: Tim Barker			

CITY OF WHARTON
 FINANCIAL STATEMENT
 AS OF: MAY 31ST, 2022

Item-1.

10 -General
 FINANCIAL SUMMARY

ACCT#	ACCOUNT NAME	ANNUAL BUDGET	CURRENT PERIOD	Y-T-D ACTUAL	% OF BUDGET	BUDGET BALANCE
<u>REVENUE SUMMARY</u>						
	Ad Valorum Taxes	596,371.00	6,150.53	553,125.82	92.75	43,245.18
	Sales Tax	1,537,000.00	162,437.31	1,183,407.64	76.99	353,592.36
	Other Taxes	1,132,270.00	33,925.66	687,260.74	60.70	445,009.26
	License and Permits	232,107.00	173,230.25	454,668.33	195.89	(222,561.33)
	Fines and Forfeitures	267,050.00	20,818.36	157,687.27	59.05	109,362.73
	Industrial District Pmt.	1,678,320.00	0.00	1,678,320.37	100.00	(0.37)
	Charges for Services	13,500.00	1,455.00	3,125.00	23.15	10,375.00
	Interest and Miscellaneous	61,500.00	401.51	16,179.01	26.31	45,320.99
	Intergovernmental	357,814.00	56,002.41	255,024.54	71.27	102,789.46
	Transfers In	992,929.00	74,543.08	620,213.56	62.46	372,715.44
		-----	-----	-----	-----	-----
**	TOTAL REVENUES **	6,868,861.00	528,964.11	5,609,012.28	81.66	1,259,848.72
		=====	=====	=====	=====	=====

<u>EXPENDITURE SUMMARY</u>						
	Mayor & Council	30,325.00	1,101.73	10,113.58	33.35	20,211.42
	City Manager	260,953.00	19,614.66	178,539.81	68.42	82,413.19
	City Secretary	186,427.00	13,502.12	122,114.83	65.50	64,312.17
	Legal and Professional Se	74,000.00	2,891.25	39,512.29	53.39	34,487.71
	Finance	327,888.00	35,757.04	220,981.56	67.40	106,906.44
	Municipal Courts	172,002.00	13,592.89	112,795.24	65.58	59,206.76
	Central Services	91,900.00	26,433.32	73,647.12	80.14	18,252.88
	Police	2,381,800.00	169,557.36	1,481,697.42	62.21	900,102.58
	Fire	446,055.00	28,959.14	290,968.03	65.23	155,086.97
	Code Enforcement	325,770.00	18,642.90	172,384.48	52.92	153,385.52
	Emergency Management	125,475.00	1,871.02	61,752.37	49.21	63,722.63
	Animal Control	73,907.00	5,450.47	43,820.95	59.29	30,086.05
	Communications	610,192.00	41,535.48	386,525.86	63.34	223,666.14
	Streets & Drainage	968,597.00	81,863.58	618,948.63	63.90	349,648.37
	Garage	138,533.00	22,758.21	106,764.53	77.07	31,768.47
	Facilities Maintenance	277,320.00	18,540.83	138,249.33	49.85	139,070.67
	Grant Admin/Housing	0.00	0.00	0.00	0.00	0.00
	Recreation	26,650.00	2,281.87	15,078.84	56.58	11,571.16
	Pool	55,375.00	3,496.01	11,224.22	20.27	44,150.78
	Grants	95,692.00	45,092.20	65,248.35	68.19	30,443.65
	Lease Payments	0.00	68,854.25	68,854.25	0.00	(68,854.25)
	Capital Outlay	200,000.00	177,453.50	329,039.94	164.52	(129,039.94)
	Transfers-Out	0.00	0.00	0.00	0.00	0.00
		-----	-----	-----	-----	-----
**	TOTAL EXPENDITURES **	6,868,861.00	799,249.83	4,548,261.63	66.22	2,320,599.37

CITY OF WHARTON
FINANCIAL STATEMENT
AS OF: MAY 31ST, 2022

Item-1.

10 -General
FINANCIAL SUMMARY

ACCT#	ACCOUNT NAME	ANNUAL BUDGET	CURRENT PERIOD	Y-T-D ACTUAL	% OF BUDGET	BUDGET BALANCE
		0.00	(270,285.72)	1,060,750.65	0.00	(1,060,750.65)

CITY OF WHARTON
 FINANCIAL STATEMENT
 AS OF: MAY 31ST, 2022

Item-1.

11 - PEG FUND
 FINANCIAL SUMMARY

ACCT#	ACCOUNT NAME	ANNUAL BUDGET	CURRENT PERIOD	Y-T-D ACTUAL	% OF BUDGET	BUDGET BALANCE
<u>REVENUE SUMMARY</u>						
	Other Taxes	3,500.00	0.00	1,566.73	44.76	1,933.27
	Interest and Miscellaneou	0.00	2.47	22.69	0.00	(22.69)
		-----	-----	-----	-----	-----
**	TOTAL REVENUES **	3,500.00	2.47	1,589.42	45.41	1,910.58
		=====	=====	=====	=====	=====
<u>EXPENDITURE SUMMARY</u>						
	Operations	3,500.00	0.00	4,984.07	142.40	(1,484.07)
		-----	-----	-----	-----	-----
**	TOTAL EXPENDITURES **	3,500.00	0.00	4,984.07	142.40	(1,484.07)
		=====	=====	=====	=====	=====
	EXCESS REVENUES/EXPENDITURES	0.00	2.47	(3,394.65)	0.00	3,394.65
		=====	=====	=====	=====	=====

CITY OF WHARTON
 FINANCIAL STATEMENT
 AS OF: MAY 31ST, 2022

Item-1.

12 -Hotel/Motel
 FINANCIAL SUMMARY

ACCT#	ACCOUNT NAME	ANNUAL BUDGET	CURRENT PERIOD	Y-T-D ACTUAL	% OF BUDGET	BUDGET BALANCE
<u>REVENUE SUMMARY</u>						
	Other Taxes	220,000.00	16,184.88	184,465.80	83.85	35,534.20
	Interest and Miscellaneou	100.00	4.35	26.92	26.92	73.08
	Intergovernmental	50,000.00	0.00	0.00	0.00	50,000.00
	Transfers In	0.00	0.00	0.00	0.00	0.00
		-----	-----	-----	-----	-----
**	TOTAL REVENUES **	270,100.00	16,189.23	184,492.72	68.31	85,607.28
		=====	=====	=====	=====	=====
<u>EXPENDITURE SUMMARY</u>						
	Operations	56,750.00	890.66	36,701.53	64.67	20,048.47
	Transfers-Out	213,350.00	0.00	125,000.00	58.59	88,350.00
		-----	-----	-----	-----	-----
**	TOTAL EXPENDITURES **	270,100.00	890.66	161,701.53	59.87	108,398.47
		=====	=====	=====	=====	=====
	EXCESS REVENUES/EXPENDITURES	0.00	15,298.57	22,791.19	0.00	(22,791.19)
		=====	=====	=====	=====	=====

CITY OF WHARTON
 FINANCIAL STATEMENT
 AS OF: MAY 31ST, 2022

Item-1.

14 -Seizure
 FINANCIAL SUMMARY

ACCT#	ACCOUNT NAME	ANNUAL BUDGET	CURRENT PERIOD	Y-T-D ACTUAL	% OF BUDGET	BUDGET BALANCE
<u>REVENUE SUMMARY</u>						
	Interest and Miscellaneou	1,700.00	3.55	38.01	2.24	1,661.99
	Intergovernmental	5,000.00	0.00	0.00	0.00	5,000.00
	Transfers In	0.00	0.00	0.00	0.00	0.00
		-----	-----	-----	-----	-----
**	TOTAL REVENUES **	6,700.00	3.55	38.01	0.57	6,661.99
		=====	=====	=====	=====	=====
<u>EXPENDITURE SUMMARY</u>						
	Operations	6,700.00	0.00	22,323.94	333.19	(15,623.94)
	Transfers-Out	0.00	0.00	0.00	0.00	0.00
		-----	-----	-----	-----	-----
**	TOTAL EXPENDITURES **	6,700.00	0.00	22,323.94	333.19	(15,623.94)
		=====	=====	=====	=====	=====
	EXCESS REVENUES/EXPENDITURES	0.00	3.55	(22,285.93)	0.00	22,285.93
		=====	=====	=====	=====	=====

CITY OF WHARTON
 FINANCIAL STATEMENT
 AS OF: MAY 31ST, 2022

Item-1.

20 -Debt Service Fund
 FINANCIAL SUMMARY

ACCT#	ACCOUNT NAME	ANNUAL BUDGET	CURRENT PERIOD	Y-T-D ACTUAL	% OF BUDGET	BUDGET BALANCE
<u>REVENUE SUMMARY</u>						
	Ad Valorum Taxes	1,822,623.00	19,284.78	1,740,010.29	95.47	82,612.71
	Interest and Miscellaneou	10,000.00	202.22	1,126.00	11.26	8,874.00
	Intergovernmental	0.00	0.00	0.00	0.00	0.00
	Transfers In	0.00	0.00	0.00	0.00	0.00
		-----	-----	-----	-----	-----
**	TOTAL REVENUES **	1,832,623.00	19,487.00	1,741,136.29	95.01	91,486.71
		=====	=====	=====	=====	=====
<u>EXPENDITURE SUMMARY</u>						
	Lease Payments	1,800,622.00	2,084,507.28	2,502,291.26	138.97	(701,669.26)
	Transfers-Out	0.00	0.00	0.00	0.00	0.00
		-----	-----	-----	-----	-----
**	TOTAL EXPENDITURES **	1,800,622.00	2,084,507.28	2,502,291.26	138.97	(701,669.26)
		=====	=====	=====	=====	=====
	EXCESS REVENUES/EXPENDITURES	32,001.00	(2,065,020.28)	(761,154.97)	378.53-	793,155.97
		=====	=====	=====	=====	=====

CITY OF WHARTON
 FINANCIAL STATEMENT
 AS OF: MAY 31ST, 2022

Item-1.

30 -Capital Improvement Fund
 FINANCIAL SUMMARY

ACCT#	ACCOUNT NAME	ANNUAL BUDGET	CURRENT PERIOD	Y-T-D ACTUAL	% OF BUDGET	BUDGET BALANCE
<u>REVENUE SUMMARY</u>						
	Interest and Miscellaneou	0.00	53.22	325.38	0.00	(325.38)
	Intergovernmental	0.00	0.00	0.00	0.00	0.00
	Transfers In	100,000.00	0.00	100,000.00	100.00	0.00
		-----	-----	-----	-----	-----
**	TOTAL REVENUES **	100,000.00	53.22	100,325.38	100.33	(325.38)
		=====	=====	=====	=====	=====
<u>EXPENDITURE SUMMARY</u>						
	Capital Outlay	100,000.00	0.00	6,300.00	6.30	93,700.00
		-----	-----	-----	-----	-----
**	TOTAL EXPENDITURES **	100,000.00	0.00	6,300.00	6.30	93,700.00
		=====	=====	=====	=====	=====
	EXCESS REVENUES/EXPENDITURES	0.00	53.22	94,025.38	0.00	(94,025.38)
		=====	=====	=====	=====	=====

CITY OF WHARTON
 FINANCIAL STATEMENT
 AS OF: MAY 31ST, 2022

Item-1.

41 -Water & Sewer Fund
 FINANCIAL SUMMARY

ACCT#	ACCOUNT NAME	ANNUAL BUDGET	CURRENT PERIOD	Y-T-D ACTUAL	% OF BUDGET	BUDGET BALANCE
<u>REVENUE SUMMARY</u>						
	Charges for Services	5,461,000.00	463,757.10	3,631,569.01	66.50	1,829,430.99
	Interest and Miscellaneou	8,500.00	389.60	9,621.44	113.19	(1,121.44)
	Intergovernmental	0.00	0.00	0.00	0.00	0.00
		-----	-----	-----	-----	-----
	** TOTAL REVENUES **	5,469,500.00	464,146.70	3,641,190.45	66.57	1,828,309.55
		=====	=====	=====	=====	=====
<u>EXPENDITURE SUMMARY</u>						
	Planning and Comm Develop	228,961.00	85,386.11	213,269.36	93.15	15,691.64
	Water/Sewer Admin.	198,991.00	16,736.22	143,951.32	72.34	55,039.68
	Water Operations	1,450,718.00	62,754.76	827,539.69	57.04	623,178.31
	Sewer Operations	980,311.00	56,455.01	587,701.18	59.95	392,609.82
	Solid Waste Operations	0.00	0.00	0.00	0.00	0.00
	Lease Payments	989,892.00	100,014.98	205,361.46	20.75	784,530.54
	Capital Outlay	626,110.00	0.00	0.00	0.00	626,110.00
	Transfers-Out	994,517.00	74,543.08	621,801.56	62.52	372,715.44
		-----	-----	-----	-----	-----
	** TOTAL EXPENDITURES **	5,469,500.00	395,890.16	2,599,624.57	47.53	2,869,875.43
		=====	=====	=====	=====	=====
	EXCESS REVENUES/EXPENDITURES	0.00	68,256.54	1,041,565.88	0.00	(1,041,565.88)
		=====	=====	=====	=====	=====

CITY OF WHARTON
 FINANCIAL STATEMENT
 AS OF: MAY 31ST, 2022

Item-1.

42 -Solid Waste Fund
 FINANCIAL SUMMARY

ACCT#	ACCOUNT NAME	ANNUAL BUDGET	CURRENT PERIOD	Y-T-D ACTUAL	% OF BUDGET	BUDGET BALANCE
<u>REVENUE SUMMARY</u>						
	Charges for Services	1,626,296.00	131,772.99	1,040,504.47	63.98	585,791.53
	Interest and Miscellaneou	800.00	333.05	1,784.55	223.07	(984.55)
		-----	-----	-----	-----	-----
	** TOTAL REVENUES **	1,627,096.00	132,106.04	1,042,289.02	64.06	584,806.98
		=====	=====	=====	=====	=====
<u>EXPENDITURE SUMMARY</u>						
	Solid Waste Operations	1,627,096.00	234,456.42	981,823.22	60.34	645,272.78
	Lease Payments	0.00	0.00	0.00	0.00	0.00
	Transfers-Out	0.00	0.00	0.00	0.00	0.00
		-----	-----	-----	-----	-----
	** TOTAL EXPENDITURES **	1,627,096.00	234,456.42	981,823.22	60.34	645,272.78
		=====	=====	=====	=====	=====
	EXCESS REVENUES/EXPENDITURES	0.00	(102,350.38)	60,465.80	0.00	(60,465.80)
		=====	=====	=====	=====	=====

CITY OF WHARTON
 FINANCIAL STATEMENT
 AS OF: MAY 31ST, 2022

Item-1.

43 -EMS Fund
 FINANCIAL SUMMARY

ACCT#	ACCOUNT NAME	ANNUAL BUDGET	CURRENT PERIOD	Y-T-D ACTUAL	% OF BUDGET	BUDGET BALANCE
<u>REVENUE SUMMARY</u>						
	Charges for Services	761,488.00	115,662.30	562,832.98	73.91	198,655.02
	Interest and Miscellaneous	2,455.00	222.39	1,412.77	57.55	1,042.23
	Intergovernmental	1,811,070.00	0.00	1,926,409.83	106.37	(115,339.83)
	Transfers In	0.00	0.00	0.00	0.00	0.00
		-----	-----	-----	-----	-----
**	TOTAL REVENUES **	2,575,013.00	115,884.69	2,490,655.58	96.72	84,357.42
		=====	=====	=====	=====	=====
<u>EXPENDITURE SUMMARY</u>						
	EMS Operations	2,476,601.00	148,474.09	1,307,862.98	52.81	1,168,738.02
	Lease Payments	0.00	0.00	0.00	0.00	0.00
	Transfers-Out	98,412.00	0.00	98,412.00	100.00	0.00
		-----	-----	-----	-----	-----
**	TOTAL EXPENDITURES **	2,575,013.00	148,474.09	1,406,274.98	54.61	1,168,738.02
		=====	=====	=====	=====	=====
	EXCESS REVENUES/EXPENDITURES	0.00	(32,589.40)	1,084,380.60	0.00	(1,084,380.60)
		=====	=====	=====	=====	=====

CITY OF WHARTON
 FINANCIAL STATEMENT
 AS OF: MAY 31ST, 2022

Item-1.

44 -Civic Center Fund
 FINANCIAL SUMMARY

ACCT#	ACCOUNT NAME	ANNUAL BUDGET	CURRENT PERIOD	Y-T-D ACTUAL	% OF BUDGET	BUDGET BALANCE
<u>REVENUE SUMMARY</u>						
	Charges for Services	62,851.00	7,736.00	44,863.50	71.38	17,987.50
	Interest and Miscellaneou	575.00	53.62	108.66	18.90	466.34
	Intergovernmental	50,000.00	0.00	50,000.00	100.00	0.00
	Transfers In	211,350.00	0.00	123,000.00	58.20	88,350.00
		-----	-----	-----	-----	-----
**	TOTAL REVENUES **	324,776.00	7,789.62	217,972.16	67.11	106,803.84
		=====	=====	=====	=====	=====
<u>EXPENDITURE SUMMARY</u>						
	Civic Center Operations	308,880.00	21,217.07	137,300.44	44.45	171,579.56
	Lease Payments	15,896.00	6,841.87	13,681.42	86.07	2,214.58
		-----	-----	-----	-----	-----
**	TOTAL EXPENDITURES **	324,776.00	28,058.94	150,981.86	46.49	173,794.14
		=====	=====	=====	=====	=====
	EXCESS REVENUES/EXPENDITURES	0.00	(20,269.32)	66,990.30	0.00	(66,990.30)
		=====	=====	=====	=====	=====

CITY OF WHARTON
 FINANCIAL STATEMENT
 AS OF: MAY 31ST, 2022

Item-1.

45 -Airport Fund
 FINANCIAL SUMMARY

ACCT#	ACCOUNT NAME	ANNUAL BUDGET	CURRENT PERIOD	Y-T-D ACTUAL	% OF BUDGET	BUDGET BALANCE
<u>REVENUE SUMMARY</u>						
	Charges for Services	273,220.00	11,763.75	187,809.53	68.74	85,410.47
	Interest and Miscellaneou	1,410.00	17.31	121.18	8.59	1,288.82
	Intergovernmental	50,000.00	0.00	30,409.41	60.82	19,590.59
	Transfers In	0.00	0.00	0.00	0.00	0.00
		-----	-----	-----	-----	-----
**	TOTAL REVENUES **	324,630.00	11,781.06	218,340.12	67.26	106,289.88
		=====	=====	=====	=====	=====
<u>EXPENDITURE SUMMARY</u>						
	Airport Operations	295,030.00	16,872.24	137,698.47	46.67	157,331.53
	Lease Payments	29,600.00	13,210.25	26,758.08	90.40	2,841.92
		-----	-----	-----	-----	-----
**	TOTAL EXPENDITURES **	324,630.00	30,082.49	164,456.55	50.66	160,173.45
		=====	=====	=====	=====	=====
	EXCESS REVENUES/EXPENDITURES	0.00	(18,301.43)	53,883.57	0.00	(53,883.57)
		=====	=====	=====	=====	=====

COMPANY: 61 - Consolidated Cash
ACCOUNT: 1000 Cash in Bank
TYPE: Check
STATUS: All
FOLIO: All

CHECK DATE: 5/01/2022 THRU 5/31/2022
CLEAR DATE: 0/00/0000 THRU 99/99/9999
STATEMENT: 0/00/0000 THRU 99/99/9999
VOIDED DATE: 0/00/0000 THRU 99/99/9999
AMOUNT: 0.00 THRU 999,999,999.99
CHECK NUMBER: 000000 THRU 999999

Item-1.

ACCOUNT	--DATE--	--TYPE--	NUMBER	-----DESCRIPTION-----	----AMOUNT---	STATUS	FOLIO	CLEAR DATE
CHECK:								
1000	5/04/2022	CHECK	111753	Sun Life Financial	2,931.38CR	OUTSTND	A	0/00/0000
1000	5/04/2022	CHECK	111754	AFLAC	1,806.42CR	OUTSTND	A	0/00/0000
1000	5/04/2022	CHECK	111755	VOID CHECK	0.00	OUTSTND	A	0/00/0000
1000	5/04/2022	CHECK	111756	Legal Shield	454.45CR	OUTSTND	A	0/00/0000
1000	5/04/2022	CHECK	111757	TML GROUP BENEFITS RISK P	69,388.03CR	OUTSTND	A	0/00/0000
1000	5/04/2022	CHECK	111758	VOID CHECK	0.00	OUTSTND	A	0/00/0000
1000	5/04/2022	CHECK	111759	VOID CHECK	0.00	OUTSTND	A	0/00/0000
1000	5/04/2022	CHECK	111760	VOID CHECK	0.00	OUTSTND	A	0/00/0000
1000	5/05/2022	CHECK	111761	KALINA NURSERY, LLC	312.50CR	OUTSTND	A	0/00/0000
1000	5/11/2022	CHECK	111762	TEXASGULF CREDIT UNION VOIDED	3,107.00CR	VOIDED	A	5/11/2022
1000	5/11/2022	CHECK	111763	WILLIAM E HEITKAMP, TRUSVOIDED	939.90CR	VOIDED	A	5/11/2022
1000	5/10/2022	CHECK	111764	PAUL WEBB	13,482.82CR	OUTSTND	A	0/00/0000
1000	5/10/2022	CHECK	111765	VOID CHECK	0.00	OUTSTND	A	0/00/0000
1000	5/10/2022	CHECK	111766	PAUL WEBB	2,891.25CR	OUTSTND	A	0/00/0000
1000	5/10/2022	CHECK	111767	QUIDDITY ENGINEERING, LLC	7,387.50CR	OUTSTND	A	0/00/0000
*** 1000	5/10/2022	CHECK	111769	ROBERTS, PEGGY & RON	22.87CR	OUTSTND	G	0/00/0000
1000	5/10/2022	CHECK	111770	TORRES, ROQUE	96.63CR	OUTSTND	G	0/00/0000
1000	5/10/2022	CHECK	111771	FLEMING, JESSICA	2.03CR	OUTSTND	G	0/00/0000
1000	5/10/2022	CHECK	111772	FIGUERA REAL ES, DAVID	62.25CR	OUTSTND	G	0/00/0000
1000	5/10/2022	CHECK	111773	COPELAND, LAUREN	10.08CR	OUTSTND	G	0/00/0000
1000	5/10/2022	CHECK	111774	HERNANDEZ, BIANCA	75.04CR	OUTSTND	G	0/00/0000
1000	5/10/2022	CHECK	111775	OFFICE OF RECOVERY SERVICES	138.46CR	OUTSTND	A	0/00/0000
1000	5/10/2022	CHECK	111776	TEXASGULF CREDIT UNION	3,107.00CR	OUTSTND	A	0/00/0000
1000	5/10/2022	CHECK	111777	WILLIAM E HEITKAMP, TRUSTEE	939.90CR	OUTSTND	A	0/00/0000
1000	5/10/2022	CHECK	111778	AMAZON CAPITAL SERVICES	148.24CR	OUTSTND	A	0/00/0000
1000	5/10/2022	CHECK	111779	AMEGY BANK OF TEXAS	228,166.00CR	OUTSTND	A	0/00/0000
1000	5/10/2022	CHECK	111780	ASCO EQUIPMENT	473.09CR	OUTSTND	A	0/00/0000
1000	5/10/2022	CHECK	111781	AT & T	1,397.57CR	OUTSTND	A	0/00/0000
1000	5/10/2022	CHECK	111782	AT&T	240.04CR	OUTSTND	A	0/00/0000
1000	5/10/2022	CHECK	111783	AT&T	1,379.01CR	OUTSTND	A	0/00/0000
1000	5/10/2022	CHECK	111784	AT&T MOBILITY	1,584.42CR	OUTSTND	A	0/00/0000
1000	5/10/2022	CHECK	111785	BOB BAKER	164.97CR	OUTSTND	A	0/00/0000
1000	5/10/2022	CHECK	111786	BARBEE SERVICES, INC.	604.08CR	OUTSTND	A	0/00/0000
1000	5/10/2022	CHECK	111787	BEFCO ENGINEERING, INC.	60,000.00CR	OUTSTND	A	0/00/0000
1000	5/10/2022	CHECK	111788	BOUND TREE MEDICAL, LLC	1,827.38CR	OUTSTND	A	0/00/0000
1000	5/10/2022	CHECK	111789	BUCKEYE CLEANING CENTER	62.05CR	OUTSTND	A	0/00/0000
1000	5/10/2022	CHECK	111790	RASHIED M BYRD	259.78CR	OUTSTND	A	0/00/0000
1000	5/10/2022	CHECK	111791	CAPITAL ONE (WALMART)	704.37CR	OUTSTND	A	0/00/0000
1000	5/10/2022	CHECK	111792	VOID CHECK	0.00	OUTSTND	A	0/00/0000
1000	5/10/2022	CHECK	111793	CENTERPOINT ENERGY	24.45CR	OUTSTND	A	0/00/0000
1000	5/10/2022	CHECK	111794	CINTAS CORPORATION	602.30CR	OUTSTND	A	0/00/0000
1000	5/10/2022	CHECK	111795	CORE & MAIN LP	2,038.79CR	OUTSTND	A	0/00/0000
1000	5/10/2022	CHECK	111796	CRAMER MARKETING	267.96CR	OUTSTND	A	0/00/0000
1000	5/10/2022	CHECK	111797	CUMMINS SOUTHERN	1,858.72CR	OUTSTND	A	0/00/0000

CHECK RECONCILIATION REGISTER

6/13/2022 8:50 AM
COMPANY: 61 - Consolidated Cash
ACCOUNT: 1000 Cash in Bank
TYPE: Check
STATUS: All
FOLIO: All

CHECK DATE: 5/01/2022 THRU 5/31/2022
CLEAR DATE: 0/00/0000 THRU 99/99/9999
STATEMENT: 0/00/0000 THRU 99/99/9999
VOIDED DATE: 0/00/0000 THRU 99/99/9999
AMOUNT: 0.00 THRU 999,999,999.99
CHECK NUMBER: 000000 THRU 999999

Item-1.

ACCOUNT	--DATE--	--TYPE--	NUMBER	-----DESCRIPTION-----	---AMOUNT---	STATUS	FOLIO	CLEAR DATE
CHECK:								
1000	5/10/2022	CHECK	111798	CUSTOM CREATIONS	42.00CR	OUTSTND	A	0/00/0000
1000	5/10/2022	CHECK	111799	DARRIN EDWARDS	75.00CR	OUTSTND	A	0/00/0000
1000	5/10/2022	CHECK	111800	DELL MARKETING L.P.	820.40CR	OUTSTND	A	0/00/0000
1000	5/10/2022	CHECK	111801	DEPARTMENT OF STATE	423.00CR	OUTSTND	A	0/00/0000
1000	5/10/2022	CHECK	111802	DEPARTMENT OF STATE HEALTH	621.40CR	OUTSTND	A	0/00/0000
1000	5/10/2022	CHECK	111803	DHARMA REED	50.00CR	OUTSTND	A	0/00/0000
1000	5/10/2022	CHECK	111804	DIRECTV	181.98CR	OUTSTND	A	0/00/0000
1000	5/10/2022	CHECK	111805	DON ELLIOTT AUTOWORLD	1,081.80CR	OUTSTND	A	0/00/0000
1000	5/10/2022	CHECK	111806	DSS DRIVING SAFETY SERVICES, L	370.00CR	OUTSTND	A	0/00/0000
1000	5/10/2022	CHECK	111807	EL CAMPO MEMORIAL HOSPITAL	65.00CR	OUTSTND	A	0/00/0000
1000	5/10/2022	CHECK	111808	EMANUEL ENTERPRISES, LLC	15,554.00CR	OUTSTND	A	0/00/0000
1000	5/10/2022	CHECK	111809	FERGUSON ENTERPRISES, INC	818.58CR	OUTSTND	A	0/00/0000
1000	5/10/2022	CHECK	111810	FORECLOSURE CLEANING & MAINTEN	811.88CR	OUTSTND	A	0/00/0000
1000	5/10/2022	CHECK	111811	GEORGIA DAVIS	200.00CR	OUTSTND	A	0/00/0000
1000	5/10/2022	CHECK	111812	GFL ENVIRONMENTAL (WCA)	51,121.23CR	OUTSTND	A	0/00/0000
1000	5/10/2022	CHECK	111813	GITA HAJARI	200.00CR	OUTSTND	A	0/00/0000
1000	5/10/2022	CHECK	111814	GREAT WESTERN DINING SERVICE,	841.90CR	OUTSTND	A	0/00/0000
1000	5/10/2022	CHECK	111815	GREEN PUMP & SUPPLY	4,946.00CR	OUTSTND	A	0/00/0000
1000	5/10/2022	CHECK	111816	BEN GUANAJUATO	270.00CR	OUTSTND	A	0/00/0000
1000	5/10/2022	CHECK	111817	JEFFERY L GUBBELS	2,230.00CR	OUTSTND	A	0/00/0000
1000	5/10/2022	CHECK	111818	HENRY SCHEIN, INC	186.30CR	OUTSTND	A	0/00/0000
1000	5/10/2022	CHECK	111819	INVENTORY TRADING COMPANY	162.00CR	OUTSTND	A	0/00/0000
1000	5/10/2022	CHECK	111820	JACKIE TEMPLE	50.00CR	OUTSTND	A	0/00/0000
1000	5/10/2022	CHECK	111821	JB GORDON JR	360.00CR	OUTSTND	A	0/00/0000
1000	5/10/2022	CHECK	111822	KATIE SMITH	200.00CR	OUTSTND	A	0/00/0000
1000	5/10/2022	CHECK	111823	C J KEARNEY	2,100.00CR	OUTSTND	A	0/00/0000
1000	5/10/2022	CHECK	111824	KINLOCH EQUIPMENT & SUPPL	1,457.87CR	OUTSTND	A	0/00/0000
1000	5/10/2022	CHECK	111825	LIBERTY EQUIPMENT	3,480.00CR	OUTSTND	A	0/00/0000
1000	5/10/2022	CHECK	111826	LLRIM	700.00CR	OUTSTND	A	0/00/0000
1000	5/10/2022	CHECK	111827	TERRY DAVID LYNCH	468.61CR	OUTSTND	A	0/00/0000
1000	5/10/2022	CHECK	111828	MAGNA FLOW ENVIRONMENTALVOIDED	3,249.28CR	VOIDED	A	5/10/2022
1000	5/10/2022	CHECK	111829	DANIEL E MAREK	126.67CR	OUTSTND	A	0/00/0000
1000	5/10/2022	CHECK	111830	MATT'S APPLIANCE SERVICE	172.44CR	OUTSTND	A	0/00/0000
1000	5/10/2022	CHECK	111831	MAYA LOTT	200.00CR	OUTSTND	A	0/00/0000
1000	5/10/2022	CHECK	111832	MCI	63.71CR	OUTSTND	A	0/00/0000
1000	5/10/2022	CHECK	111833	MES - TEXAS	1,424.94CR	OUTSTND	A	0/00/0000
1000	5/10/2022	CHECK	111834	METRO FIRE APPARATUS	238.00CR	OUTSTND	A	0/00/0000
1000	5/10/2022	CHECK	111835	MORALES HOME & LAWN CARE, INC	2,500.00CR	OUTSTND	A	0/00/0000
1000	5/10/2022	CHECK	111836	NAPCO CHEMICAL COMPANY, INC	1,900.00CR	OUTSTND	A	0/00/0000
1000	5/10/2022	CHECK	111837	O'REILLY AUTOMOTIVE STORES, IN	1,012.59CR	OUTSTND	A	0/00/0000
1000	5/10/2022	CHECK	111838	VOID CHECK	0.00	OUTSTND	A	0/00/0000
1000	5/10/2022	CHECK	111839	PERCHERON, LLC	12,050.00CR	OUTSTND	A	0/00/0000
1000	5/10/2022	CHECK	111840	PITNEY BOWES BANK INC	200.00CR	OUTSTND	A	0/00/0000
1000	5/10/2022	CHECK	111841	POINT EMBLEMS	410.00CR	OUTSTND	A	0/00/0000

CHECK RECONCILIATION REGISTER

6/13/2022 8:50 AM

COMPANY: 61 - Consolidated Cash
 ACCOUNT: 1000 Cash in Bank
 TYPE: Check
 STATUS: All
 FOLIO: All

CHECK DATE: 5/01/2022 THRU 5/31/2022
 CLEAR DATE: 0/00/0000 THRU 99/99/9999
 STATEMENT: 0/00/0000 THRU 99/99/9999
 VOIDED DATE: 0/00/0000 THRU 99/99/9999
 AMOUNT: 0.00 THRU 999,999,999.99
 CHECK NUMBER: 000000 THRU 999999

Item-1.

ACCOUNT	--DATE--	--TYPE--	NUMBER	-----DESCRIPTION-----	---AMOUNT---	STATUS	FOLIO	CLEAR DATE
CHECK:								
1000	5/10/2022	CHECK	111842	THE POLICE AND SHERIFFS PRESS,	50.16CR	OUTSTND	A	0/00/0000
1000	5/10/2022	CHECK	111843	PROSPERITY BANK	1,041.15CR	OUTSTND	A	0/00/0000
1000	5/10/2022	CHECK	111844	QUADMED, INC.	119.95CR	OUTSTND	A	0/00/0000
1000	5/10/2022	CHECK	111845	QUIDDITY ENGINEERING, LLC	49,463.23CR	OUTSTND	A	0/00/0000
1000	5/10/2022	CHECK	111846	VOID CHECK	0.00	OUTSTND	A	0/00/0000
1000	5/10/2022	CHECK	111847	QUILL CORPORATION	778.20CR	OUTSTND	A	0/00/0000
1000	5/10/2022	CHECK	111848	VOID CHECK	0.00	OUTSTND	A	0/00/0000
1000	5/10/2022	CHECK	111849	RICHMOND RD. TRUCK & AUTO PART	1,455.52CR	OUTSTND	A	0/00/0000
1000	5/10/2022	CHECK	111850	VOID CHECK	0.00	OUTSTND	A	0/00/0000
1000	5/10/2022	CHECK	111851	RMA TOLL PROCESSING	11.38CR	OUTSTND	A	0/00/0000
1000	5/10/2022	CHECK	111852	ROBERSON A/C & REFRIGERAT	1,531.00CR	OUTSTND	A	0/00/0000
1000	5/10/2022	CHECK	111853	SHERWIN WILLIAMS	359.00CR	OUTSTND	A	0/00/0000
1000	5/10/2022	CHECK	111854	SPARKLIGHT/ NEWWAVE	133.44CR	OUTSTND	A	0/00/0000
1000	5/10/2022	CHECK	111855	STAR PARTS INC	19.67CR	OUTSTND	A	0/00/0000
1000	5/10/2022	CHECK	111856	STROUHAL TIRE	871.52CR	OUTSTND	A	0/00/0000
1000	5/10/2022	CHECK	111857	TEC-TRONIC SYSTEMS, INC	64.98CR	OUTSTND	A	0/00/0000
1000	5/10/2022	CHECK	111858	TEXAS COMMISSION ON LAW ENFORC	70.00CR	OUTSTND	A	0/00/0000
1000	5/10/2022	CHECK	111859	TEXAS QUALITY LAWN EQUIPMENT	39.99CR	OUTSTND	A	0/00/0000
1000	5/10/2022	CHECK	111860	TEXAS WORKFORCE COMMISSIO	10,497.57CR	OUTSTND	A	0/00/0000
1000	5/10/2022	CHECK	111861	TITAN AVIATION FUELS	34,428.11CR	OUTSTND	A	0/00/0000
1000	5/10/2022	CHECK	111862	TRACTOR SUPPLY CREDIT PLAN	127.74CR	OUTSTND	A	0/00/0000
1000	5/10/2022	CHECK	111863	TRANTEX TRANSPORTATION	355.00CR	OUTSTND	A	0/00/0000
1000	5/10/2022	CHECK	111864	TYLER TECHNOLOGIES, INC.	974.00CR	OUTSTND	A	0/00/0000
1000	5/10/2022	CHECK	111865	VC3 INC	180.76CR	OUTSTND	A	0/00/0000
1000	5/10/2022	CHECK	111866	VERIZON WIRELESS	626.64CR	OUTSTND	A	0/00/0000
1000	5/10/2022	CHECK	111867	WHARTON COUNTY ELECTRIC C	1,340.44CR	OUTSTND	A	0/00/0000
1000	5/10/2022	CHECK	111868	VOID CHECK	0.00	OUTSTND	A	0/00/0000
1000	5/10/2022	CHECK	111869	PAUL WEBB	2,189.20CR	OUTSTND	A	0/00/0000
1000	5/10/2022	CHECK	111870	WHARTON COUNTY SHERIFF'S OFFIC	133.50CR	OUTSTND	A	0/00/0000
1000	5/10/2022	CHECK	111871	WHARTON EZ LUBE	7.00CR	OUTSTND	A	0/00/0000
1000	5/10/2022	CHECK	111872	WHARTON FEED & SUPPLY	25.00CR	OUTSTND	A	0/00/0000
1000	5/10/2022	CHECK	111873	WHARTON LAWN & GARDEN	236.00CR	OUTSTND	A	0/00/0000
1000	5/10/2022	CHECK	111874	WHARTON VETERINARY CLINIC, PLL	174.60CR	OUTSTND	A	0/00/0000
1000	5/10/2022	CHECK	111875	ZBRANEK GRAVEL, LLC	8,331.93CR	OUTSTND	A	0/00/0000
1000	5/10/2022	CHECK	111876	PRUDENTIA, INC.	8,196.86CR	OUTSTND	A	0/00/0000
1000	5/10/2022	CHECK	111877	MELANIE HARRIS	50.00CR	OUTSTND	A	0/00/0000
1000	5/17/2022	CHECK	111878	GRANTWORKS	39,000.00CR	OUTSTND	A	0/00/0000
1000	5/17/2022	CHECK	111879	UNITED STATES POST OFFICE	204.25CR	OUTSTND	A	0/00/0000
1000	5/17/2022	CHECK	111880	WHARTON CO CLERK	54.00CR	OUTSTND	A	0/00/0000
1000	5/17/2022	CHECK	111881	WHARTON CO CLERK	208.00CR	OUTSTND	A	0/00/0000
1000	5/24/2022	CHECK	111882	TEXASGULF CREDIT UNION	3,107.00CR	OUTSTND	A	0/00/0000
1000	5/24/2022	CHECK	111883	WILLIAM E HEITKAMP, TRUSTEE	939.90CR	OUTSTND	A	0/00/0000
1000	5/24/2022	CHECK	111884	OFFICE OF RECOVERY SERVICES	138.46CR	OUTSTND	A	0/00/0000
*** 1000	5/25/2022	CHECK	111886	AGENCY 405 - CRIME RECORDS SER	3.00CR	OUTSTND	A	0/00/0000

CHECK RECONCILIATION REGISTER

6/13/2022 8:50 AM

COMPANY: 61 - Consolidated Cash
 ACCOUNT: 1000 Cash in Bank
 TYPE: Check
 STATUS: All
 FOLIO: All

CHECK DATE: 5/01/2022 THRU 5/31/2022
 CLEAR DATE: 0/00/0000 THRU 99/99/9999
 STATEMENT: 0/00/0000 THRU 99/99/9999
 VOIDED DATE: 0/00/0000 THRU 99/99/9999
 AMOUNT: 0.00 THRU 999,999,999.99
 CHECK NUMBER: 000000 THRU 999999

Item-1.

ACCOUNT	--DATE--	--TYPE--	NUMBER	-----DESCRIPTION-----	---AMOUNT---	STATUS	FOLIO	CLEAR DATE
CHECK:								
1000	5/25/2022	CHECK	111887	ALLIED BREATHING AIR	747.19CR	OUTSTND	A	0/00/0000
1000	5/25/2022	CHECK	111888	AMAZON CAPITAL SERVICES	516.45CR	OUTSTND	A	0/00/0000
1000	5/25/2022	CHECK	111889	ANIMAL CARE EQUIPMENT	90.55CR	OUTSTND	A	0/00/0000
1000	5/25/2022	CHECK	111890	AQUA-TECH LABORATORIES, I	3,709.00CR	OUTSTND	A	0/00/0000
1000	5/25/2022	CHECK	111891	ARADYNE INDUSTRIES, INC	872.10CR	OUTSTND	A	0/00/0000
1000	5/25/2022	CHECK	111892	ARANDA INDUSTRIES, LLC	266,660.25CR	OUTSTND	A	0/00/0000
1000	5/25/2022	CHECK	111893	ASCO EQUIPMENT	4,813.00CR	OUTSTND	A	0/00/0000
1000	5/25/2022	CHECK	111894	AT & T	1,467.95CR	OUTSTND	A	0/00/0000
1000	5/25/2022	CHECK	111895	VOID CHECK	0.00	OUTSTND	A	0/00/0000
1000	5/25/2022	CHECK	111896	AT&T	133.69CR	OUTSTND	A	0/00/0000
1000	5/25/2022	CHECK	111897	AT&T	1,381.02CR	OUTSTND	A	0/00/0000
1000	5/25/2022	CHECK	111898	AT&T GLOBAL SERVICES, INC.	7,742.16CR	OUTSTND	A	0/00/0000
1000	5/25/2022	CHECK	111899	AT&T MOBILITY	631.69CR	OUTSTND	A	0/00/0000
1000	5/25/2022	CHECK	111900	AUTOZONE, INC.	438.20CR	OUTSTND	A	0/00/0000
1000	5/25/2022	CHECK	111901	BACK 40 CARWASH, LLC	150.00CR	OUTSTND	A	0/00/0000
1000	5/25/2022	CHECK	111902	BARBEE SERVICES, INC.	2,018.94CR	OUTSTND	A	0/00/0000
1000	5/25/2022	CHECK	111903	VOID CHECK	0.00	OUTSTND	A	0/00/0000
1000	5/25/2022	CHECK	111904	BLS CONSTRUCTION INC	796.00CR	OUTSTND	A	0/00/0000
1000	5/25/2022	CHECK	111905	BOUND TREE MEDICAL, LLC	1,831.75CR	OUTSTND	A	0/00/0000
1000	5/25/2022	CHECK	111906	VOID CHECK	0.00	OUTSTND	A	0/00/0000
1000	5/25/2022	CHECK	111907	VOID CHECK	0.00	OUTSTND	A	0/00/0000
1000	5/25/2022	CHECK	111908	BRAZORIA COUNTY WATER LAB	255.00CR	OUTSTND	A	0/00/0000
1000	5/25/2022	CHECK	111909	BUGABUG	588.00CR	OUTSTND	A	0/00/0000
1000	5/25/2022	CHECK	111910	RASHIED M BYRD	41.61CR	OUTSTND	A	0/00/0000
1000	5/25/2022	CHECK	111911	CAPITAL ONE (WALMART)	873.20CR	OUTSTND	A	0/00/0000
1000	5/25/2022	CHECK	111912	VOID CHECK	0.00	OUTSTND	A	0/00/0000
1000	5/25/2022	CHECK	111913	CENTERPOINT ENERGY	356.34CR	OUTSTND	A	0/00/0000
1000	5/25/2022	CHECK	111914	VOID CHECK	0.00	OUTSTND	A	0/00/0000
1000	5/25/2022	CHECK	111915	CHERYL'S EXXON	28.00CR	OUTSTND	A	0/00/0000
1000	5/25/2022	CHECK	111916	CLARK SUPPLY	53.93CR	OUTSTND	A	0/00/0000
1000	5/25/2022	CHECK	111917	JARED CULLAR	539.19CR	OUTSTND	A	0/00/0000
1000	5/25/2022	CHECK	111918	CUSTOM CREATIONS	331.00CR	OUTSTND	A	0/00/0000
1000	5/25/2022	CHECK	111919	DEPARTMENT OF STATE HEALTH	213.92CR	OUTSTND	A	0/00/0000
1000	5/25/2022	CHECK	111920	DIRECTV	188.23CR	OUTSTND	A	0/00/0000
1000	5/25/2022	CHECK	111921	DISTRICT CLERK OF WHARTON CO.	450.00CR	OUTSTND	A	0/00/0000
1000	5/25/2022	CHECK	111922	DON ELLIOTT AUTOWORLD	1,701.18CR	OUTSTND	A	0/00/0000
1000	5/25/2022	CHECK	111923	DRANE RANGER	2,105.00CR	OUTSTND	A	0/00/0000
1000	5/25/2022	CHECK	111924	DSS DRIVING SAFETY SERVICES, L	440.00CR	OUTSTND	A	0/00/0000
1000	5/25/2022	CHECK	111925	E-CONTRACTORS USA, LLC	980,737.37CR	OUTSTND	A	0/00/0000
1000	5/25/2022	CHECK	111926	EL CAMPO MEMORIAL HOSPITAL	1,273.50CR	OUTSTND	A	0/00/0000
1000	5/25/2022	CHECK	111927	EL CAMPO SPRAYING, INC	5,252.23CR	OUTSTND	A	0/00/0000
1000	5/25/2022	CHECK	111928	SHANNON COURVILLE	456.00CR	OUTSTND	A	0/00/0000
1000	5/25/2022	CHECK	111929	FEDEX	35.33CR	OUTSTND	A	0/00/0000
1000	5/25/2022	CHECK	111930	FERGUSON ENTERPRISES, INC	5,647.24CR	OUTSTND	A	0/00/0000

CHECK RECONCILIATION REGISTER

6/13/2022 8:50 AM

COMPANY: 61 - Consolidated Cash
 ACCOUNT: 1000 Cash in Bank
 TYPE: Check
 STATUS: All
 FOLIO: All

CHECK DATE: 5/01/2022 THRU 5/31/2022
 CLEAR DATE: 0/00/0000 THRU 99/99/99
 STATEMENT: 0/00/0000 THRU 99/99/99
 VOIDED DATE: 0/00/0000 THRU 99/99/9999
 AMOUNT: 0.00 THRU 999,999,999.99
 CHECK NUMBER: 000000 THRU 999999

Item-1.

ACCOUNT	--DATE--	--TYPE--	NUMBER	-----DESCRIPTION-----	----AMOUNT---	STATUS	FOLIO	CLEAR DATE
CHECK:								
1000	5/25/2022	CHECK	111931	FORECLOSURE CLEANING & MAINTEN	811.88CR	OUTSTND	A	0/00/0000
1000	5/25/2022	CHECK	111932	FOSTER FENCE LTD	7,255.00CR	OUTSTND	A	0/00/0000
1000	5/25/2022	CHECK	111933	FRAZER LTD	87.29CR	OUTSTND	A	0/00/0000
1000	5/25/2022	CHECK	111934	JASON R GANGSTAD	479.14CR	OUTSTND	A	0/00/0000
1000	5/25/2022	CHECK	111935	GFL ENVIRONMENTAL (WCA)	74,598.71CR	OUTSTND	A	0/00/0000
1000	5/25/2022	CHECK	111936	GOLD STAR PETROLEUM, INC.	20,375.46CR	OUTSTND	A	0/00/0000
1000	5/25/2022	CHECK	111937	GREAT WESTERN DINING SERVICE,	551.50CR	OUTSTND	A	0/00/0000
1000	5/25/2022	CHECK	111938	GROUP & PENSION ADMIN, INC	231.02CR	OUTSTND	A	0/00/0000
1000	5/25/2022	CHECK	111939	GULF COAST PAPER CO VOIDED	126.48CR	VOIDED	A	5/25/2022
1000	5/25/2022	CHECK	111940	HARRIS COUNTY A/R RADIO	127.50CR	OUTSTND	A	0/00/0000
1000	5/25/2022	CHECK	111941	HARRISON, WALDROP,	8,000.00CR	OUTSTND	A	0/00/0000
1000	5/25/2022	CHECK	111942	HDR ENGINEERING, INC.	11,253.59CR	OUTSTND	A	0/00/0000
1000	5/25/2022	CHECK	111943	HEB CREDIT RECEIVABLES	21.70CR	OUTSTND	A	0/00/0000
1000	5/25/2022	CHECK	111944	HENRY SCHEIN, INC	1,078.31CR	OUTSTND	A	0/00/0000
1000	5/25/2022	CHECK	111945	HODGES WELDING SUPPLY	415.60CR	OUTSTND	A	0/00/0000
1000	5/25/2022	CHECK	111946	HOUSTON BEARING & SUPPLY	650.00CR	OUTSTND	A	0/00/0000
1000	5/25/2022	CHECK	111947	MARIA C. BRUCIA	345.00CR	OUTSTND	A	0/00/0000
1000	5/25/2022	CHECK	111948	HUNGERFORD CO-OP	125.95CR	OUTSTND	A	0/00/0000
1000	5/25/2022	CHECK	111949	IMPACT PROMOTIONAL SERVICES, L	19.73CR	OUTSTND	A	0/00/0000
1000	5/25/2022	CHECK	111950	INSURANCENET	71.00CR	OUTSTND	A	0/00/0000
1000	5/25/2022	CHECK	111951	JAKYRA ROBLES	200.00CR	OUTSTND	A	0/00/0000
1000	5/25/2022	CHECK	111952	JTM CONSTRUCTION, LLC	35,180.10CR	OUTSTND	A	0/00/0000
1000	5/25/2022	CHECK	111953	C J KEARNEY	2,100.00CR	OUTSTND	A	0/00/0000
1000	5/25/2022	CHECK	111954	KULP 106.7FM & 1390AM	150.00CR	OUTSTND	A	0/00/0000
1000	5/25/2022	CHECK	111955	LEAH KING	200.00CR	OUTSTND	A	0/00/0000
1000	5/25/2022	CHECK	111956	LIFE-ASSIST, INC.	99.45CR	OUTSTND	A	0/00/0000
1000	5/25/2022	CHECK	111957	LINEBARGER GOGGAN BLAIR	4,039.46CR	OUTSTND	A	0/00/0000
1000	5/25/2022	CHECK	111958	LORI MATA	200.00CR	OUTSTND	A	0/00/0000
1000	5/25/2022	CHECK	111959	MAGNA FLOW ENVIRONMENTAL, INC.	2,776.19CR	OUTSTND	A	0/00/0000
1000	5/25/2022	CHECK	111960	MARILYN JOHNSON	200.00CR	OUTSTND	A	0/00/0000
1000	5/25/2022	CHECK	111961	METRO FIRE APPARATUS	3,642.67CR	OUTSTND	A	0/00/0000
1000	5/25/2022	CHECK	111962	MINER, LTD DBA OVERHEAD DOOR C	2,309.72CR	OUTSTND	A	0/00/0000
1000	5/25/2022	CHECK	111963	MOBILE COMMUNICATIONS AMERICA,	600.00CR	OUTSTND	A	0/00/0000
1000	5/25/2022	CHECK	111964	MUSTANG CAT	54.01CR	OUTSTND	A	0/00/0000
1000	5/25/2022	CHECK	111965	NATIONAL PEN CO. LLC	110.94CR	OUTSTND	A	0/00/0000
1000	5/25/2022	CHECK	111966	NORTHERN SAFETY CO., INC.	249.09CR	OUTSTND	A	0/00/0000
1000	5/25/2022	CHECK	111967	NUTRIEN AG SOLUTIONS	260.00CR	OUTSTND	A	0/00/0000
1000	5/25/2022	CHECK	111968	O'REILLY AUTOMOTIVE STORES, IN	398.35CR	OUTSTND	A	0/00/0000
1000	5/25/2022	CHECK	111969	VOID CHECK	0.00	OUTSTND	A	0/00/0000
1000	5/25/2022	CHECK	111970	OFFICE DEPOT	1,607.88CR	OUTSTND	A	0/00/0000
1000	5/25/2022	CHECK	111971	STEVEN M. BURKE	1,780.00CR	OUTSTND	A	0/00/0000
1000	5/25/2022	CHECK	111972	JOSEPH R FACE	200.42CR	OUTSTND	A	0/00/0000
1000	5/25/2022	CHECK	111973	PEKAR'S BODY SHOP, INC.	3,959.48CR	OUTSTND	A	0/00/0000
1000	5/25/2022	CHECK	111974	PHIL'S PLUMBING CO.	481.28CR	OUTSTND	A	0/00/0000

COMPANY: 61 - Consolidated Cash
ACCOUNT: 1000 Cash in Bank
TYPE: Check
STATUS: All
FOLIO: All

CHECK DATE: 5/01/2022 THRU 5/31/2022
CLEAR DATE: 0/00/0000 THRU 99/99/9999
STATEMENT: 0/00/0000 THRU 99/99/9999
VOIDED DATE: 0/00/0000 THRU 99/99/9999
AMOUNT: 0.00 THRU 999,999,999.99
CHECK NUMBER: 000000 THRU 999999

Item-1.

ACCOUNT	--DATE--	--TYPE--	NUMBER	-----DESCRIPTION-----	---AMOUNT---	STATUS	FOLIO	CLEAR DATE
CHECK:								
1000	5/25/2022	CHECK	111975	PITNEY BOWES BANK INC	500.00CR	OUTSTND	A	0/00/0000
1000	5/25/2022	CHECK	111976	PITNEY BOWES BANK INC	76.99CR	OUTSTND	A	0/00/0000
1000	5/25/2022	CHECK	111977	POLYDYNE INC	1,363.50CR	OUTSTND	A	0/00/0000
1000	5/25/2022	CHECK	111978	POSTMASTER	265.00CR	OUTSTND	A	0/00/0000
1000	5/25/2022	CHECK	111979	PROSPERITY BANK	708.34CR	OUTSTND	A	0/00/0000
1000	5/25/2022	CHECK	111980	VOID CHECK	0.00	OUTSTND	A	0/00/0000
1000	5/25/2022	CHECK	111981	VOID CHECK	0.00	OUTSTND	A	0/00/0000
1000	5/25/2022	CHECK	111982	PROVANTAGE LLC	455.40CR	OUTSTND	A	0/00/0000
1000	5/25/2022	CHECK	111983	PUBLIC MANAGEMENT, INC	12,000.00CR	OUTSTND	A	0/00/0000
1000	5/25/2022	CHECK	111984	PUMPS OF HOUSTON, INC	1,900.00CR	OUTSTND	A	0/00/0000
1000	5/25/2022	CHECK	111985	QT PETROLEUM ON DEMAND	1,425.00CR	OUTSTND	A	0/00/0000
1000	5/25/2022	CHECK	111986	QUALITY HOT-MIX INC	1,881.00CR	OUTSTND	A	0/00/0000
1000	5/25/2022	CHECK	111987	QUILL CORPORATION	1,730.60CR	OUTSTND	A	0/00/0000
1000	5/25/2022	CHECK	111988	VOID CHECK	0.00	OUTSTND	A	0/00/0000
1000	5/25/2022	CHECK	111989	RACHEL ROBERSON	43.55CR	OUTSTND	A	0/00/0000
1000	5/25/2022	CHECK	111990	REGINA FERNANDEZ	500.00CR	OUTSTND	A	0/00/0000
1000	5/25/2022	CHECK	111991	RELIANT ENERGY	24,972.11CR	OUTSTND	A	0/00/0000
1000	5/25/2022	CHECK	111992	VOID CHECK	0.00	OUTSTND	A	0/00/0000
1000	5/25/2022	CHECK	111993	VOID CHECK	0.00	OUTSTND	A	0/00/0000
1000	5/25/2022	CHECK	111994	VOID CHECK	0.00	OUTSTND	A	0/00/0000
1000	5/25/2022	CHECK	111995	VOID CHECK	0.00	OUTSTND	A	0/00/0000
1000	5/25/2022	CHECK	111996	VOID CHECK	0.00	OUTSTND	A	0/00/0000
1000	5/25/2022	CHECK	111997	VOID CHECK	0.00	OUTSTND	A	0/00/0000
1000	5/25/2022	CHECK	111998	VOID CHECK	0.00	OUTSTND	A	0/00/0000
1000	5/25/2022	CHECK	111999	VOID CHECK	0.00	OUTSTND	A	0/00/0000
1000	5/25/2022	CHECK	112000	VOID CHECK	0.00	OUTSTND	A	0/00/0000
1000	5/25/2022	CHECK	112001	VOID CHECK	0.00	OUTSTND	A	0/00/0000
1000	5/25/2022	CHECK	112002	VOID CHECK	0.00	OUTSTND	A	0/00/0000
1000	5/25/2022	CHECK	112003	VOID CHECK	0.00	OUTSTND	A	0/00/0000
1000	5/25/2022	CHECK	112004	VOID CHECK	0.00	OUTSTND	A	0/00/0000
1000	5/25/2022	CHECK	112005	VOID CHECK	0.00	OUTSTND	A	0/00/0000
1000	5/25/2022	CHECK	112006	VOID CHECK	0.00	OUTSTND	A	0/00/0000
1000	5/25/2022	CHECK	112007	VOID CHECK	0.00	OUTSTND	A	0/00/0000
1000	5/25/2022	CHECK	112008	REYNA'S CAFE	753.96CR	OUTSTND	A	0/00/0000
1000	5/25/2022	CHECK	112009	RICHMOND RD. TRUCK & AUTO PART	1,373.98CR	OUTSTND	A	0/00/0000
1000	5/25/2022	CHECK	112010	VOID CHECK	0.00	OUTSTND	A	0/00/0000
1000	5/25/2022	CHECK	112011	VOID CHECK	0.00	OUTSTND	A	0/00/0000
1000	5/25/2022	CHECK	112012	RICOH USA, INC.	2,494.85CR	OUTSTND	A	0/00/0000
1000	5/25/2022	CHECK	112013	ROBERSON A/C & REFRIGERAT	1,113.00CR	OUTSTND	A	0/00/0000
1000	5/25/2022	CHECK	112014	ROTARY CLUB OF WHARTON	40.00CR	OUTSTND	A	0/00/0000
1000	5/25/2022	CHECK	112015	SCHMIDT IMPLEMENT INC.	259.99CR	OUTSTND	A	0/00/0000
1000	5/25/2022	CHECK	112016	SETRAC	625.00CR	OUTSTND	A	0/00/0000
1000	5/25/2022	CHECK	112017	SHADAVIA WOODARD	500.00CR	OUTSTND	A	0/00/0000
1000	5/25/2022	CHECK	112018	SHERWIN WILLIAMS	762.40CR	OUTSTND	A	0/00/0000

COMPANY: 61 - Consolidated Cash
ACCOUNT: 1000 Cash in Bank
TYPE: Check
STATUS: All
FOLIO: All

CHECK DATE: 5/01/2022 THRU 5/31/2022
CLEAR DATE: 0/00/0000 THRU 99/99/9999
STATEMENT: 0/00/0000 THRU 99/99/9999
VOIDED DATE: 0/00/0000 THRU 99/99/9999
AMOUNT: 0.00 THRU 999,999,999.99
CHECK NUMBER: 000000 THRU 999999

Item-1.

ACCOUNT	--DATE--	--TYPE--	NUMBER	-----DESCRIPTION-----	---AMOUNT---	STATUS	FOLIO	CLEAR DATE
CHECK:								
1000	5/25/2022	CHECK	112019	SHI GOVERNMENT	3,796.77CR	OUTSTND	A	0/00/0000
1000	5/25/2022	CHECK	112020	SNAP-ON INDUSTRIAL	773.22CR	OUTSTND	A	0/00/0000
1000	5/25/2022	CHECK	112021	SOUTH TEXAS CORRUGATED	1,526.80CR	OUTSTND	A	0/00/0000
1000	5/25/2022	CHECK	112022	SOUTHWEST SOLUTIONS GROUP, INC	188.37CR	OUTSTND	A	0/00/0000
1000	5/25/2022	CHECK	112023	SPARKLIGHT/ NEWWAVE	44.18CR	OUTSTND	A	0/00/0000
1000	5/25/2022	CHECK	112024	STAR PARTS INC	318.06CR	OUTSTND	A	0/00/0000
1000	5/25/2022	CHECK	112025	VOID CHECK	0.00	OUTSTND	A	0/00/0000
1000	5/25/2022	CHECK	112026	VOID CHECK	0.00	OUTSTND	A	0/00/0000
1000	5/25/2022	CHECK	112027	STROUHAL TIRE	2,421.28CR	OUTSTND	A	0/00/0000
1000	5/25/2022	CHECK	112028	VOID CHECK	0.00	OUTSTND	A	0/00/0000
1000	5/25/2022	CHECK	112029	SUMMIT FIRE & SECURITY	1,511.00CR	OUTSTND	A	0/00/0000
1000	5/25/2022	CHECK	112030	SUTHERLAND LUMBER CO.	422.86CR	OUTSTND	A	0/00/0000
1000	5/25/2022	CHECK	112031	PATRICK KRPEC DBA	271.40CR	OUTSTND	A	0/00/0000
1000	5/25/2022	CHECK	112032	T J WELDING & FABRICATION	360.00CR	OUTSTND	A	0/00/0000
1000	5/25/2022	CHECK	112033	TEC-TRONIC SYSTEMS, INC	4,065.94CR	OUTSTND	A	0/00/0000
1000	5/25/2022	CHECK	112034	TELEFLEX LLC	1,215.50CR	OUTSTND	A	0/00/0000
1000	5/25/2022	CHECK	112035	TEXAS DEPT OF TRANSPORTATION	175,011.00CR	OUTSTND	A	0/00/0000
1000	5/25/2022	CHECK	112036	TEXAS ENGINEERING EXTENSION SE	455.00CR	OUTSTND	A	0/00/0000
1000	5/25/2022	CHECK	112037	TEXAS QUALITY LAWN EQUIPMENT	84.99CR	OUTSTND	A	0/00/0000
1000	5/25/2022	CHECK	112038	THOMSON REUTERS - WEST	242.11CR	OUTSTND	A	0/00/0000
1000	5/25/2022	CHECK	112039	TITAN AVIATION FUELS	36,163.62CR	OUTSTND	A	0/00/0000
1000	5/25/2022	CHECK	112040	TRACTOR SUPPLY CREDIT PLAN	57.98CR	OUTSTND	A	0/00/0000
1000	5/25/2022	CHECK	112041	TRAFCO INDUSTRIES, INC.	72.00CR	OUTSTND	A	0/00/0000
1000	5/25/2022	CHECK	112042	TRANTEX TRANSPORTATION	72.76CR	OUTSTND	A	0/00/0000
1000	5/25/2022	CHECK	112043	TYLER TECHNOLOGIES, INC.	836.09CR	OUTSTND	A	0/00/0000
1000	5/25/2022	CHECK	112044	UPS	40.33CR	OUTSTND	A	0/00/0000
1000	5/25/2022	CHECK	112045	USA BLUE BOOK	1,172.49CR	OUTSTND	A	0/00/0000
1000	5/25/2022	CHECK	112046	VC3 INC	1,545.00CR	OUTSTND	A	0/00/0000
1000	5/25/2022	CHECK	112047	VERIZON CONNECT NWF, INC.	97.14CR	OUTSTND	A	0/00/0000
1000	5/25/2022	CHECK	112048	VERIZON WIRELESS	2,358.63CR	OUTSTND	A	0/00/0000
1000	5/25/2022	CHECK	112049	PAUL WEBB	1,632.50CR	OUTSTND	A	0/00/0000
1000	5/25/2022	CHECK	112050	WHARTON CO CLERK	26.00CR	OUTSTND	A	0/00/0000
1000	5/25/2022	CHECK	112051	WHARTON CO TIRE COMPANY I	22.00CR	OUTSTND	A	0/00/0000
1000	5/25/2022	CHECK	112052	WHARTON COUNTY CENTRAL APPRAIS	10,572.75CR	OUTSTND	A	0/00/0000
1000	5/25/2022	CHECK	112053	WHARTON COUNTY SHERIFF'S OFFIC	400.50CR	OUTSTND	A	0/00/0000
1000	5/25/2022	CHECK	112054	WHARTON INDEPENDENT	31,389.95CR	OUTSTND	A	0/00/0000
1000	5/25/2022	CHECK	112055	WHARTON JOURNAL SPECTATOR	1,052.63CR	OUTSTND	A	0/00/0000
1000	5/25/2022	CHECK	112056	WHARTON LAWN & GARDEN	132.56CR	OUTSTND	A	0/00/0000
1000	5/25/2022	CHECK	112057	LARRY SITKA	100.00CR	OUTSTND	A	0/00/0000
1000	5/26/2022	CHECK	112058	JOSEPH R PACE	818.18CR	OUTSTND	A	0/00/0000
1000	5/26/2022	CHECK	112059	PROSPERITY BANK	788,854.25CR	OUTSTND	A	0/00/0000
1000	5/31/2022	CHECK	112060	CITY OF WHARTON	100.00CR	OUTSTND	A	0/00/0000
1000	5/31/2022	CHECK	112061	GOVERNMENT FINANCE OFFICERS AS	460.00CR	OUTSTND	A	0/00/0000
1000	5/31/2022	CHECK	112062	MASON'S PLUMBING CO, LLC	645.00CR	OUTSTND	A	0/00/0000

CHECK RECONCILIATION REGISTER

6/13/2022 8:50 AM
 COMPANY: 61 - Consolidated Cash
 ACCOUNT: 1000 Cash in Bank
 TYPE: Check
 STATUS: All
 FOLIO: All

CHECK DATE: 5/01/2022 THRU 5/31/2022
 CLEAR DATE: 0/00/0000 THRU 99/99/9999
 STATEMENT: 0/00/0000 THRU 99/99/9999
 VOIDED DATE: 0/00/0000 THRU 99/99/9999
 AMOUNT: 0.00 THRU 999,999,999.99
 CHECK NUMBER: 000000 THRU 999999

Item-1.

ACCOUNT	--DATE--	--TYPE--	NUMBER	-----DESCRIPTION-----	---AMOUNT---	STATUS	FOLIO	CLEAR DATE
CHECK:								
1000	5/31/2022	CHECK	112063	UNITED STATES POST OFFICE	1,004.38CR	OUTSTND	A	0/00/0000
1000	5/31/2022	CHECK	112064	WADLER, PERCHES, HUNDL & KERLI	6,883.27CR	OUTSTND	A	0/00/0000
TOTALS FOR ACCOUNT 1000				CHECK	TOTAL:	3,307,886.73CR		
				DEPOSIT	TOTAL:	0.00		
				INTEREST	TOTAL:	0.00		
				MISCELLANEOUS	TOTAL:	0.00		
				SERVICE CHARGE	TOTAL:	0.00		
				EFT	TOTAL:	0.00		
				BANK-DRAFT	TOTAL:	0.00		
TOTALS FOR Consolidated Cash				CHECK	TOTAL:	3,307,886.73CR		
				DEPOSIT	TOTAL:	0.00		
				INTEREST	TOTAL:	0.00		
				MISCELLANEOUS	TOTAL:	0.00		
				SERVICE CHARGE	TOTAL:	0.00		
				EFT	TOTAL:	0.00		
				BANK-DRAFT	TOTAL:	0.00		

6/13/2022 8:52 AM
 COMPANY: 61 - Consolidated Cash
 ACCOUNT: 1000 Cash in Bank
 TYPE: Check
 STATUS: All
 FOLIO: All

CHECK RECONCILIATION REGISTER

PAGE: 1
 CHECK DATE: 5/01/2022 THRU 5/31/2022
 CLEAR DATE: 0/00/0000 THRU 99/99/99
 STATEMENT: 0/00/0000 THRU 99/99/99
 VOIDED DATE: 0/00/0000 THRU 99/99/9999
 AMOUNT: 5,000.00 THRU 999,999,999.99
 CHECK NUMBER: 000000 THRU 999999

Item-1.

ACCOUNT	--DATE--	--TYPE--	NUMBER	-----DESCRIPTION-----	-----AMOUNT---	STATUS	FOLIO	CLEAR DATE
CHECK:								
1000	5/04/2022	CHECK	111757	TML GROUP BENEFITS RISK P	69,388.03CR	OUTSTND	A	0/00/0000
*** 1000	5/10/2022	CHECK	111764	PAUL WEBB	13,482.82CR	OUTSTND	A	0/00/0000
*** 1000	5/10/2022	CHECK	111767	QUIDDITY ENGINEERING, LLC	7,387.50CR	OUTSTND	A	0/00/0000
*** 1000	5/10/2022	CHECK	111779	AMEGY BANK OF TEXAS	228,166.00CR	OUTSTND	A	0/00/0000
*** 1000	5/10/2022	CHECK	111787	BEFCO ENGINEERING, INC.	60,000.00CR	OUTSTND	A	0/00/0000
*** 1000	5/10/2022	CHECK	111808	EMANUEL ENTERPRISES, LLC	15,554.00CR	OUTSTND	A	0/00/0000
*** 1000	5/10/2022	CHECK	111812	GFL ENVIRONMENTAL (WCA)	51,121.23CR	OUTSTND	A	0/00/0000
*** 1000	5/10/2022	CHECK	111839	PERCHERON, LLC	12,050.00CR	OUTSTND	A	0/00/0000
*** 1000	5/10/2022	CHECK	111845	QUIDDITY ENGINEERING, LLC	49,463.23CR	OUTSTND	A	0/00/0000
*** 1000	5/10/2022	CHECK	111860	TEXAS WORKFORCE COMMISSIO	10,497.57CR	OUTSTND	A	0/00/0000
1000	5/10/2022	CHECK	111861	TITAN AVIATION FUELS	34,428.11CR	OUTSTND	A	0/00/0000
*** 1000	5/10/2022	CHECK	111875	ZBRANEK GRAVEL, LLC	8,331.93CR	OUTSTND	A	0/00/0000
1000	5/10/2022	CHECK	111876	PRUDENTIA, INC.	8,196.86CR	OUTSTND	A	0/00/0000
*** 1000	5/17/2022	CHECK	111878	GRANTWORKS	39,000.00CR	OUTSTND	A	0/00/0000
*** 1000	5/25/2022	CHECK	111892	ARANDA INDUSTRIES, LLC	266,660.25CR	OUTSTND	A	0/00/0000
*** 1000	5/25/2022	CHECK	111898	AT&T GLOBAL SERVICES, INC.	7,742.16CR	OUTSTND	A	0/00/0000
*** 1000	5/25/2022	CHECK	111925	E-CONTRACTORS USA, LLC	980,737.37CR	OUTSTND	A	0/00/0000
*** 1000	5/25/2022	CHECK	111927	EL CAMPO SPRAYING, INC	5,252.23CR	OUTSTND	A	0/00/0000
*** 1000	5/25/2022	CHECK	111930	FERGUSON ENTERPRISES, INC	5,647.24CR	OUTSTND	A	0/00/0000
*** 1000	5/25/2022	CHECK	111932	FOSTER FENCE LTD	7,255.00CR	OUTSTND	A	0/00/0000
*** 1000	5/25/2022	CHECK	111935	GFL ENVIRONMENTAL (WCA)	74,598.71CR	OUTSTND	A	0/00/0000
1000	5/25/2022	CHECK	111936	GOLD STAR PETROLEUM, INC.	20,375.46CR	OUTSTND	A	0/00/0000
*** 1000	5/25/2022	CHECK	111941	HARRISON, WALDROP,	8,000.00CR	OUTSTND	A	0/00/0000
1000	5/25/2022	CHECK	111942	HDR ENGINEERING, INC.	11,253.59CR	OUTSTND	A	0/00/0000
*** 1000	5/25/2022	CHECK	111952	JTM CONSTRUCTION, LLC	35,180.10CR	OUTSTND	A	0/00/0000
*** 1000	5/25/2022	CHECK	111983	PUBLIC MANAGEMENT, INC	12,000.00CR	OUTSTND	A	0/00/0000
*** 1000	5/25/2022	CHECK	111991	RELIANT ENERGY	24,972.11CR	OUTSTND	A	0/00/0000
*** 1000	5/25/2022	CHECK	112035	TEXAS DEPT OF TRANSPORTATION	175,011.00CR	OUTSTND	A	0/00/0000
*** 1000	5/25/2022	CHECK	112039	TITAN AVIATION FUELS	36,163.62CR	OUTSTND	A	0/00/0000
*** 1000	5/25/2022	CHECK	112052	WHARTON COUNTY CENTRAL APPRAIS	10,572.75CR	OUTSTND	A	0/00/0000
*** 1000	5/25/2022	CHECK	112054	WHARTON INDEPENDENT	31,389.95CR	OUTSTND	A	0/00/0000
*** 1000	5/26/2022	CHECK	112059	PROSPERITY BANK	788,854.25CR	OUTSTND	A	0/00/0000
*** 1000	5/31/2022	CHECK	112064	WADLER, PERCHES, HUNDL & KERLI	6,883.27CR	OUTSTND	A	0/00/0000

2019 Tax Notes, Payment
 Levee Asbestos Abatement

Herbicide- Airport
 PW Gate Operate

2020 Tax Notes
 Paym

TOTALS FOR ACCOUNT 1000

CHECK	TOTAL:	3,115,616.34CR
DEPOSIT	TOTAL:	0.00
INTEREST	TOTAL:	0.00
MISCELLANEOUS	TOTAL:	0.00
SERVICE CHARGE	TOTAL:	0.00
EFT	TOTAL:	0.00
BANK-DRAFT	TOTAL:	0.00

- (A) - Utility Abandonment - Levee
- (B) - Utility Abandonment - Levee
- (C) - American Rescue Plan - Recovery Funding
- (D) - Cow Levee Project - Attorney AD LITEM Fees

**CITY OF WHARTON
PROSPERITY
BANK BALANCES**

<u>Account</u>	<u>05/31/22</u>
General	\$902,990.59
PEG	\$14,530.88
Hotel/Motel	\$28,792.75
Municipal Technology	\$6,521.23
Seizure	\$20,922.12
Fire Special Revenue	\$395.27
Municipal Building	\$56,640.98
Debt	\$103,582.38
2017 Tax Notes	\$324,190.43
2011 Tax & Rev Bond	\$182,943.50
2013 Bond	\$8,159.09
Capital Improvement	\$313,371.13
QECB	\$811,781.03
2015 Bond	\$142,431.52
USDA Water Well	\$1,115,625.68
2019 Tax Anticipation Notes	\$376,478.64
2019 Bond	\$1,367,479.10
2020 Tax Notes Series	\$953,186.93
FM 1301 Project	\$13,428,256.64
Utility SIB	\$5,383,148.34
Water/Sewer	\$1,268,818.89
Solid Waste	\$35,731.65
EMS	\$716,951.56
Civic Center	\$50,127.30
Airport	\$68,932.81
Consolidated Cash	\$838,475.16
Payroll	\$3,718.13
Credit Card Clearing	\$19,481.32
Railroad Depot	\$514.18
	<u><u>\$28,544,179.23</u></u>

Monthly average yield for May 2022 was .20%

OTHER INVESTMENTS

DEBT FUND

Texasgulf Credit Union	\$2,840.21
------------------------	------------

**TEXPOOL INVESTMENTS
SUMMARY OF ACCOUNTS
FOR THE MONTH ENDING MAY 2022**

ACCOUNT	BEGINNING BALANCE 05/01/22	INVESTMENTS	RETIREMENTS	INTEREST EARNED	ENDING BALANCE 05/31/22
General Fund	3,222.84	1,100,000.00	0.00	324.22	1,103,547.06
Hotel/Motel Fund	102.02	-	0.00	0.00	102.02
Municipal Court Technology	272.58	-	0.00	0.16	272.74
Seizure Fund	3,683.04	-	0.00	1.92	3,684.96
Municipal Court Building Security	3,902.29	-	0.00	2.07	3,904.36
Debt Service	2,800.08	-	0.00	1.43	2,801.51
2011 Tax & Rev Bond	3,031.59	1,000,000.00	0.00	99.17	1,003,130.76
2019 Tax Anticipation Notes	593.89	-	0.00	0.31	594.20
2019 Bond	3,841.84	-	0.00	2.03	3,843.87
Water & Sewer Fund	1,296.71	1,000,000.00	0.00	268.62	1,001,565.33
Solid Water Fund	486.76	-	0.00	0.27	487.03
EMS Fund	3,393.47	1,000,000.00	0.00	250.97	1,003,644.44
Civic Center Fund	468.48	-	0.00	0.27	468.75
Airport Fund	3,920.81	-	0.00	2.07	3,922.88
TOTAL TEXPOOL INVESTMENTS	\$31,016.40	\$4,100,000.00	\$0.00	\$953.51	\$4,131,969.91

The monthly average yield for May was .62%

The City of Wharton's investments are in compliance with the investment strategy as expressed in the investment policy and with the relevant provisions of Chapter 2256 of the Texas Government Code and with Generally Accepted Accounting Principles.

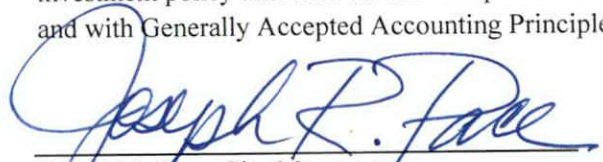
Joseph R. Face, City Manager

Joan Andel, Finance Director

CITY OF WHARTON

June 2022

SELECTED FINANCIAL INFORMATION

AD VOLAREM TAXES - CURRENT TAXES	Actual YTD FY 2020-21	Actual YTD FY 2021-22	% Change
Assessed Value	551,520,031	598,254,016	8.47%
Exemptions	(11,529,427)	(11,884,280)	3.08%
Net Taxable Value Before Freeze	539,990,604	586,369,736	8.59%
Less: Total Freeze Taxable	(80,665,028)	(87,310,619)	N/A
Freeze Adjusted Taxable	459,325,576	499,059,117	8.65%
Tax Rate per \$100 Value	0.43726	0.41917	-4.14%
Tax Levy Before Freeze Ceiling	2,008,447	2,091,906	4.16%
Plus: Freeze Ceiling	269,160	272,141	N/A
Tax Levy	2,277,607	2,364,047	3.80%
Estimated Delinquency	(68,328)	(70,921)	3.79%
Estimated Tax Revenue	2,209,279	2,293,126	3.80%
Actual Collections to Date-Current	2,171,374	2,241,744	3.24%
Variance Over (Under) from Estimated Collections	(37,905)	(51,382)	

ANALYSIS OF SALES TAX

	FY 2020-2021 Actual			FY 2021-2022 Actual			FY 2022	Comparisons			
	City	WEDCO	Total	City	WEDCO	Total	Net	2020-21 to 2021-22		2021-22 to Budget	
							Budget	\$ Dif	% Dif	\$ Dif	% Dif
October	124,207	62,104	186,311	129,433	64,717	194,150	129,532	5,226	4.21%	(99)	-0.08%
November	132,457	66,228	198,685	145,513	72,757	218,270	137,688	13,056	9.86%	7,825	5.68%
December	176,526	88,263	264,789	189,606	94,803	284,409	166,317	13,080	7.41%	23,289	14.00%
January	126,875	63,437	190,312	124,993	62,497	187,490	117,162	(1,882)	-1.48%	7,831	6.68%
February	122,308	61,154	183,462	124,026	62,013	186,039	112,641	1,718	1.40%	11,385	10.11%
March	178,026	89,013	267,039	162,437	81,219	243,656	167,802	(15,589)	-8.76%	(5,364)	-3.20%
April	152,841	76,420	229,261	144,558	72,279	216,837	147,868	(8,282)	-5.42%	(3,310)	-2.24%
May	136,653	68,327	204,980	0	0	-	131,843				
June	153,591	76,795	230,386	0	0	0	149,468				
July	145,755	72,877	218,632	0	0	0	140,853				
August	138,957	69,479	208,436	0	0	0	134,124				
September	168,441	84,221	252,662	0	0	0	163,313				
Total	1,756,637	878,318	2,634,955	1,020,567	510,284	1,530,851	1,698,610	7,328	0.72%	41,557	4.24%



Monthly Newsletter: June 2022

ANNOUNCEMENTS

We welcome the following entities who joined TexPool in May 2022:

- TexPool**
 McKinney MUD 2 of Collin County
 North Hays County MUD 2
 Montgomery County MUD 186

TexPool Prime
 Viridian Municipal Management District

- Upcoming Events**
 June 15, 2022 - June 17, 2022
Texas Association of Community College Business Officers (TACCBO) Annual Meeting and Conference
 Waco Convention Center, Waco, TX
 June 23, 2022 - June 25, 2022
Association of Water Board Directors Annual Conference
 Fort Worth Convention Center, Fort Worth, TX
 June 26, 2022 - June 28, 2022
Texas Association of State Senior College and University Business Officers (TASSCUBO) Summer Conference
 Hyatt Regency - Lost Pines Resort, Bastrop, TX

TexPool Advisory Board Members

- | | |
|---------------------|-----------------|
| Patrick Krishock | Jerry Dale |
| Belinda Weaver | David Landeros |
| Deborah Lauder milk | Sharon Matthews |
| Valarie Van Vlack | David Garcia |

Overseen by the State of Texas Comptroller of Public Accounts Glenn Hegar
 Operated under the supervision of the Texas Treasury Safekeeping Trust Company

TexPool Participant Services is Now Paperless!

As of January 3, 2022, participants are no longer required to send original documentation for requests that have been submitted via email or fax. For questions, contact 1-866-839-7665.

Economic and Market Commentary: Ear to the ground

June 1, 2022

The cautious and shrewd way Federal Reserve policymakers communicate can put diplomats to shame. But the success of their decisions in the coming months will depend upon how well they listen.

Managing monetary policy in the midst of a global pandemic has been, and remains extraordinarily difficult. No one can deny that. But the Fed’s response to mounting inflation in the last several quarters showed it wanted to stick to its new paradigm in the face of facts. If you recall, in August of 2020, it recast its policy framework to allow inflation to exceed 2% as long as the labor market is strong. Officials not only viewed rising prices in 2021 as “transient,” but also a positive after years of undershooting 2%.

While telegraphing 50 basis-point hikes in the next two FOMC meetings, minutes from the last meeting and recent official speeches suggest the committee might pause to assess their impact. In other words, they will—and should—return to making decisions based on data in the fight against inflation without inducing a recession. Policymakers have to listen to what the economy is telling them on a

(continued page 6)

Performance as of May 31, 2022

	TexPool	TexPool Prime
Current Invested Balance	\$26,022,107,081	\$10,635,158,204
Weighted Average Maturity**	25 Days	20 Days
Weighted Average Life**	93 Days	58 Days
Net Asset Value	0.99978	0.99978
Total Number of Participants	2,709	459
Management Fee on Invested Balance	0.0450%	0.0550%
Interest Distributed	\$13,838,421.11	\$7,424,020.28
Management Fee Collected	\$646,076.49	\$412,632.62
Standard & Poor’s Current Rating	AAAm	AAAm

Month Averages

Average Invested Balance	\$26,221,171,318	\$10,775,834,407
Average Monthly Rate*	0.62%	0.81%
Average Weighted Average Maturity**	23	20
Average Weighted Average Life**	94	60

*This average monthly rate for TexPool Prime for each date may reflect a waiver of some portion or all of each of the management fees.

**See page 2 for definitions.

Past performance is no guarantee of future results.



Portfolio by Maturity (%)

As of May 31, 2022

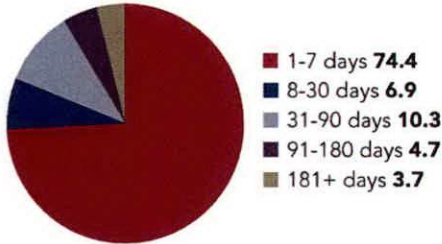

Portfolio by Type of Investment (%)

As of May 31, 2022

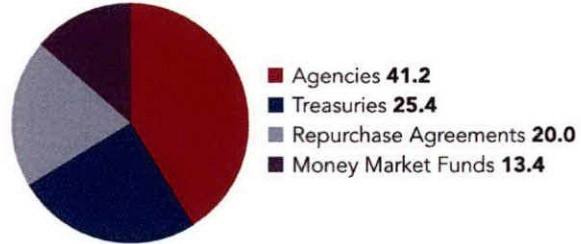

Portfolio Asset Summary as of May 31, 2022

	Book Value	Market Value
Uninvested Balance	\$746.58	\$746.58
Receivable for Investments Sold	0.00	0.00
Accrual of Interest Income	13,239,410.71	13,239,410.71
Interest and Management Fees Payable	-13,838,432.26	-13,838,432.26
Payable for Investments Purchased	-124,001,527.50	-124,001,527.50
Accrued Expenses & Taxes	-22,376.48	-22,376.48
Repurchase Agreements	5,243,484,686.00	5,243,484,686.00
Mutual Fund Investments	3,523,074,000.00	3,523,074,000.00
Government Securities	9,245,226,335.03	9,244,988,725.23
US Treasury Bills	4,134,504,337.74	4,131,382,419.99
US Treasury Notes	4,000,439,901.11	3,998,160,483.24
Total	\$26,022,107,080.93	\$26,016,468,135.51

Market value of collateral supporting the Repurchase Agreements is at least 102% of the Book Value. The portfolio is managed by Federated Investment Counseling and the assets are safe kept in a separate custodial account at State Street Bank in the name of TexPool. The only source of payment to the Participants is the assets of TexPool. There is no secondary source of payment for the pool such as insurance or State guarantee. Should you require a copy of the portfolio, please contact TexPool Participant Services.

Participant Summary

	Number of Participants	Balance
School District	600	\$7,638,449,744.20
Higher Education	60	\$1,289,120,802.59
County	196	\$2,995,984,987.19
Healthcare	90	\$1,532,766,056.58
Utility District	886	\$4,393,089,869.11
City	484	\$6,901,234,828.38
Emergency Districts	98	\$330,418,973.51
Economic Development Districts	84	\$171,186,657.74
Other	211	\$769,869,228.35

**Definition of Weighted Average Maturity and Weighted Average Life

WAM is the mean average of the periods of time remaining until the securities held in TexPool (a) are scheduled to be repaid, (b) would be repaid upon a demand by TexPool, or (c) are scheduled to have their interest rate readjusted to reflect current market rates. Securities with adjustable rates payable upon demand are treated as maturing on the earlier of the two dates set forth in (b) and (c) if their scheduled maturity is 397 days or less; and the later of the two dates set forth in (b) and (c) if their scheduled maturity is more than 397 days. The mean is weighted based on the percentage of the amortized cost of the portfolio invested in each period.

WAL is calculated in the same manner as WAM, but is based solely on the periods of time remaining until the securities held in TexPool (a) are scheduled to be repaid or (b) would be repaid upon a demand by TexPool, without reference to when interest rates of securities within TexPool are scheduled to be readjusted.



Daily Summary						
Date	Money Mkt. Fund Equiv. (SEC Std.)	Dividend Factor	TexPool Invested Balance	NAV	WAM Days	WAL Days
5/1	0.3209%	0.000008791	\$26,686,291,199.96	0.99971	24	99
5/2	0.3282%	0.000008993	\$26,721,113,902.65	0.99972	22	95
5/3	0.3236%	0.000008865	\$26,749,907,699.92	0.99971	22	95
5/4	0.3305%	0.000009055	\$26,779,341,693.65	0.99971	22	95
5/5	0.4123%	0.000011296	\$26,933,106,444.34	0.99973	21	94
5/6	0.6406%	0.000017551	\$26,648,179,969.34	0.99974	22	94
5/7	0.6406%	0.000017551	\$26,648,179,969.34	0.99974	22	94
5/8	0.6406%	0.000017551	\$26,648,179,969.34	0.99974	22	94
5/9	0.6336%	0.000017359	\$26,552,367,695.53	0.99974	20	92
5/10	0.6405%	0.000017549	\$26,154,271,419.60	0.99974	21	93
5/11	0.6402%	0.000017539	\$26,106,387,490.90	0.99974	21	93
5/12	0.6523%	0.000017870	\$25,998,946,761.15	0.99975	20	93
5/13	0.6550%	0.000017946	\$26,137,115,435.18	0.99974	21	94
5/14	0.6550%	0.000017946	\$26,137,115,435.18	0.99974	21	94
5/15	0.6550%	0.000017946	\$26,137,115,435.18	0.99974	21	94
5/16	0.6764%	0.000018532	\$25,995,106,573.71	0.99973	21	93
5/17	0.6792%	0.000018608	\$25,969,460,405.71	0.99972	22	92
5/18	0.6861%	0.000018798	\$26,064,506,012.10	0.99973	22	92
5/19	0.6806%	0.000018647	\$26,054,847,987.47	0.99975	22	93
5/20	0.6850%	0.000018767	\$25,994,738,308.41	0.99976	23	93
5/21	0.6850%	0.000018767	\$25,994,738,308.41	0.99976	23	93
5/22	0.6850%	0.000018767	\$25,994,738,308.41	0.99976	23	93
5/23	0.6878%	0.000018845	\$25,869,010,549.74	0.99976	24	93
5/24	0.6883%	0.000018857	\$25,848,336,382.55	0.99979	24	93
5/25	0.7080%	0.000019398	\$26,060,476,934.71	0.99979	24	94
5/26	0.7154%	0.000019600	\$26,127,323,709.97	0.99980	24	94
5/27	0.7145%	0.000019576	\$25,955,824,946.20	0.99979	26	95
5/28	0.7145%	0.000019576	\$25,955,824,946.20	0.99979	26	95
5/29	0.7145%	0.000019576	\$25,955,824,946.20	0.99979	26	95
5/30	0.7145%	0.000019576	\$25,955,824,946.20	0.99979	26	95
5/31	0.7023%	0.000019242	\$26,022,107,080.93	0.99978	25	93
Average:	0.6228%	0.000017063	\$26,221,171,318.33	0.99975	23	94



TEXPOOL Prime

Portfolio by Maturity (%)

As of May 31, 2022

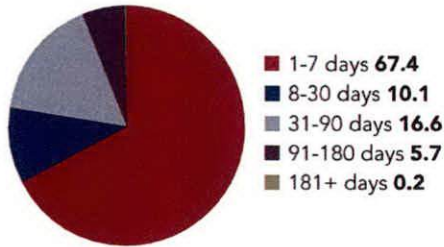

Portfolio by Type of Investment (%)

As of May 31, 2022

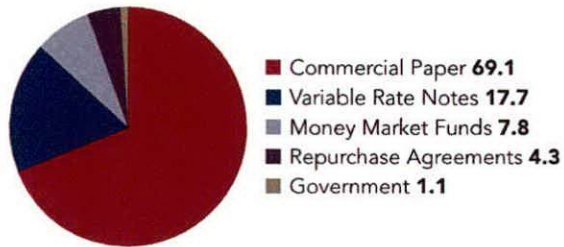

Portfolio Asset Summary as of May 31, 2022

	Book Value	Market Value
Uninvested Balance	\$172,209.74	\$172,209.74
Receivable for Investments Sold	0.00	0.00
Accrual of Interest Income	2,305,265.68	2,305,265.68
Interest and Management Fees Payable	-7,424,019.61	-7,424,019.61
Payable for Investments Purchased	0.00	0.00
Accrued Expenses & Taxes	-13,738.82	-13,738.82
Repurchase Agreements	460,454,000.00	460,454,000.00
Commercial Paper	7,347,003,373.21	7,345,362,559.43
Mutual Fund Investments	830,153,483.22	829,941,055.05
Government Securities	117,508,597.69	117,650,987.50
Variable Rate Notes	1,884,999,033.14	1,884,304,550.00
Total	\$10,635,158,204.25	\$10,632,752,868.97

Market value of collateral supporting the Repurchase Agreements is at least 102% of the Book Value. The portfolio is managed by Federated Investment Counseling and the assets are safe kept in a separate custodial account at State Street Bank in the name of TexPool Prime. The assets of TexPool Prime are the only source of payments to the Participants. There is no secondary source of payment for the pool such as insurance or State guarantee. Should you require a copy of the portfolio, please contact TexPool Participant Services

Participant Summary

	Number of Participants	Balance
School District	132	\$3,675,800,727.03
Higher Education	19	\$638,277,676.04
County	49	\$751,731,964.49
Healthcare	18	\$460,878,852.44
Utility District	50	\$652,575,465.98
City	90	\$2,120,789,558.85
Emergency Districts	21	\$46,607,373.85
Economic Development Districts	15	\$23,419,852.07
Other	65	\$2,264,987,709.79



TEXPOOL Prime

Daily Summary

Date	Money Mkt. Fund Equiv. (SEC Std.)	Dividend Factor	TexPool Prime Invested Balance	NAV	WAM Days	WAL Days
5/1	0.4725%	0.000012944	\$11,093,562,421.49	0.99970	19	56
5/2	0.4784%	0.000013108	\$11,032,374,624.30	0.99970	17	54
5/3	0.4814%	0.000013189	\$10,889,890,600.35	0.99970	17	57
5/4	0.5316%	0.000014564	\$10,807,687,211.16	0.99968	18	58
5/5	0.6486%	0.000017771	\$10,747,437,932.84	0.99969	20	61
5/6	0.7633%	0.000020911	\$10,840,794,096.32	0.99968	22	62
5/7	0.7633%	0.000020911	\$10,840,794,096.32	0.99968	22	62
5/8	0.7633%	0.000020911	\$10,840,794,096.32	0.99968	22	62
5/9	0.8768%	0.000024023	\$10,863,709,272.42	0.99973	20	60
5/10	0.8593%	0.000023543	\$10,863,522,289.39	0.99974	21	61
5/11	0.8467%	0.000023198	\$10,904,091,617.65	0.99974	20	60
5/12	0.8568%	0.000023475	\$10,862,638,002.65	0.99974	21	61
5/13	0.8575%	0.000023492	\$10,825,997,281.72	0.99970	21	60
5/14	0.8575%	0.000023492	\$10,825,997,281.72	0.99970	21	60
5/15	0.8575%	0.000023492	\$10,825,997,281.72	0.99970	21	60
5/16	0.8608%	0.000023583	\$10,773,001,551.25	0.99974	19	58
5/17	0.8702%	0.000023841	\$10,755,459,027.46	0.99975	20	59
5/18	0.8756%	0.000023989	\$10,829,862,665.85	0.99975	20	61
5/19	0.8833%	0.000024200	\$10,802,201,862.94	0.99974	21	62
5/20	0.8837%	0.000024210	\$10,721,565,463.46	0.99971	21	62
5/21	0.8837%	0.000024210	\$10,721,565,463.46	0.99971	21	62
5/22	0.8837%	0.000024210	\$10,721,565,463.46	0.99971	21	62
5/23	0.8800%	0.000024073	\$10,637,552,318.25	0.99975	19	60
5/24	0.8849%	0.000024245	\$10,666,262,957.23	0.99975	19	59
5/25	0.8878%	0.000024324	\$10,684,032,418.31	0.99976	19	59
5/26	0.9016%	0.000024700	\$10,685,983,896.88	0.99976	21	61
5/27	0.9166%	0.000025113	\$10,587,841,801.45	0.99972	23	62
5/28	0.9166%	0.000025113	\$10,587,841,801.45	0.99972	23	62
5/29	0.9166%	0.000025113	\$10,587,841,801.45	0.99972	23	62
5/30	0.9166%	0.000025113	\$10,587,841,801.45	0.99972	23	62
5/31	0.9122%	0.000024992	\$10,635,158,204.25	0.99978	20	58
Average:	0.8125%	0.000022260	\$10,775,834,406.61	0.99972	20	60



Participant Services
1001 Texas Ave. Suite 1150
Houston, TX 77002

scale much smaller and a timeframe much shorter than they prefer. This is no time for long-view academic studies.

Reports already indicate that this economy might be more responsive to shifts in monetary policy than traditionally expected. The housing market, consumer outlook and industrial production are cooling off. It is not unreasonable to think that supply-chain bottlenecks and energy prices exacerbated by China's shutdown and the war in Ukraine could improve by the fall. Data dependency is a cliché that completely applies here.

What of investors? The bond market seems to be declaring victory over inflation and the stock market is betting on the worst-case scenario. Investors in the short end of the Treasury yield curve are acting more rationally, although the supply/demand imbalance, especially in the front end, has caused it to trade much lower in yield. In addition to the supply/demand imbalance, the flight-to-safety trade has depressed Treasury yields further. You have to go to the 6-month section of the curve to find yields above the Fed's Reverse Repo Facility. But administered rates on bank deposits have not budged much because banks still are flush with cash and don't want deposits—especially now that the cost of lending is increasing. We think the money market securities in which government pools can invest are in a good place and are a good place for investment.

At the end of May, yields on 1-, 3-, 6- and 12-month U.S. Treasuries were 0.71%, 1.05%, 1.54% and 2%, respectively;

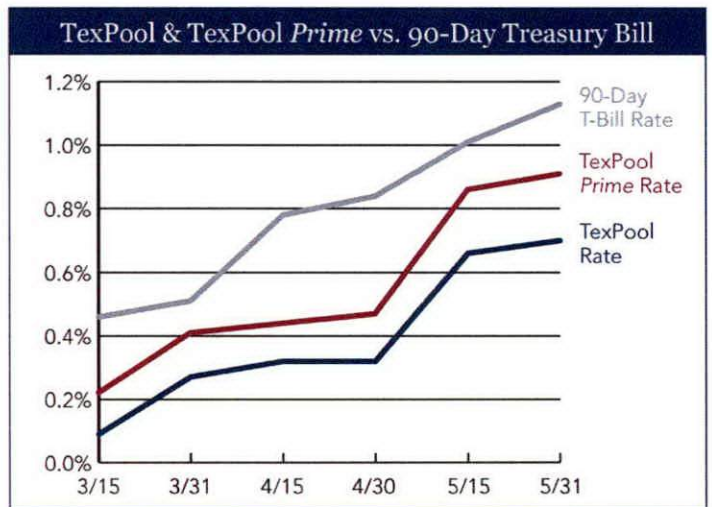

90-Day Treasury Bill is a short-term debt instrument backed by the national government. These are used to collect immediate cash to meet outstanding obligations.

Any private investor can invest in a Treasury bill. The 90-Day Treasury Bill is a weighted average rate of the weekly auctions of 90-Day Treasury Bills.

Past performance is no guarantee of future results.

the 1-, 3-, 6- and 12-month Bloomberg Short-Term Bank Yield Index rates (BSBY) were 0.96%, 1.54%, 2.04% and 2.68%, respectively; and the 1-, 3-, 6- and 12-month London interbank offered rates were 1.12%, 1.63%, 2.11% and 2.78%, respectively.

Wharton County Tax Office

Run Date: 6/1/2022 10:22:46AM

Distribution Summary 2 Report

Page 6 of 23

Start Date from 05/01/2022 to 05/31/2022 and Tax Unit Numbers = {multiple}

CWH - CITY OF WHARTON

Current Levy M&O	5,681.28	Delinquent Levy M&O	741.09
Current Penalty M&O	366.91	Delinquent Penalty M&O	78.24
Current Interest M&O	159.26	Delinquent Interest M&O	230.83
Current Other M&O	(0.90)	Delinquent Other M&O	0.00
Cur Rendition Penalty M&O	87.42	Delq Rendition Penalty M&O	10.93
Cur Rendition Fraud M&O	0.00	Delq Rendition Fraud M&O	0.00
Total Current M&O	6,293.97	Total Delinquent M&O	1,061.09
Current Levy I&S	18,199.97	Delinquent Levy I&S	2,142.92
Current Penalty I&S	1,148.69	Delinquent Penalty I&S	228.05
Current Interest I&S	498.33	Delinquent Interest I&S	501.21
Current Other I&S	(2.87)	Delinquent Other I&S	0.00
Cur Rendition Penalty I&S	0.00	Delq Rendition Penalty I&S	0.00
Cur Rendition Fraud I&S	0.00	Delq Rendition Fraud I&S	0.00
Total Current I&S	19,844.12	Total Delinquent I&S	2,872.18

Current Levy	23,881.25	Delinquent Levy	2,884.01
Current Penalty	1,515.60	Delinquent Penalty	306.29
Current Interest	657.59	Delinquent Interest	732.04
Current Other	(3.77)	Delinquent Other	0.00
Cur Rendition Penalty	87.42	Delq Rendition Penalty	10.93
Cur Rendition Fraud	0.00	Delq Rendition Fraud	0.00
Total Current	26,138.09	Total Delinquent	3,933.27

Grand Total M&O	7,355.06
-----------------	----------

Grand Total I&S	22,716.30
-----------------	-----------

Grand Total S1	0.00
----------------	------

Total Due to Jurisdiction	30,071.36
---------------------------	-----------

Total Due to Delq Tax Atty	816.54
----------------------------	--------

City of Wharton
 120 E. Caney Street
 Wharton, TX 77488

CITY COUNCIL COMMUNICATION

Meeting Date:	6/27/2022	Agenda Item:	Utility Easement Agreements: A. Resolution: A resolution of the Wharton City Council accepting a Utility Easement Agreement between the City of Wharton and Russell J. Baird for William Kincheloe League, Abstract No. 38, Wharton County, Texas, Block 1, Lot 3, 4, 5 & 6, of the Baird Subdivision and authorizing the Mayor of the City of Wharton to execute said agreement. B. Resolution: A resolution of the Wharton City Council accepting a Utility Easement Agreement between the City of Wharton and Justin D. & Kristina D. Crouch for William Kincheloe League, Abstract No. 38, Wharton County, Texas, Block 1, Lot 1 & 2, of the Baird Subdivision and authorizing the Mayor of the City of Wharton to execute said agreement.
---------------	-----------	--------------	--

Mr. Baird has been remodeling his buildings in downtown Wharton and has been working to revitalize them for the economic advantage of the downtown area. The City Staff has been working with Mr. Baird to assist with the utilities on his property to allow for the properties to be portioned out as single units. During this process it was discovered that there was an existing sanitary sewer line behind the building without the proper easement and a new easement would be required for the new water line that needs to be installed. In order for the utilities to be in the required and appropriate easement it is the recommendation to enter into an agreement with both Mr. Baird who owns Lots 3, 4, 5 & 6 and Mr. & Mrs. Crouch, who own Lots 1 & 2 for a 20' utility easement on their property. The City Staff is working with Kolacny Surveying to complete the metes and bounds exhibits for the agreements to be filed with the County Clerk's Office and these are to be provided prior to signatures or filing.

Attached are the draft easement agreements and resolutions to enter into the agreements. The agreements have been reviewed by the City Attorney and meet with their approval.

Director of Planning & Development, Gwyn Teves, will be present to answer any questions.

City Manager: Joseph R. Pace	Date: Thursday, June 23, 2022
Approval: 	
Mayor: Tim Barker	



City of Wharton

120 E. Caney • Wharton, TX 77488
Phone (979) 532-2491 • Fax (979) 532-0181

MEMORANDUM

DATE: June 21, 2022

FROM: Gwyneth Teves, Director of Planning & Development

TO: Honorable Mayor and City Council

SUBJECT: Utility Easement Agreement with Russell J. Baird and Justin D. & Kristina C. Crouch for William Kincheloe League, Abstract No. 38, Block 1, Lot 1, 2, 3, 4, 5 & 6 of the Baird Subdivision

Mr. Baird has been remodeling his buildings in downtown Wharton and has been working to revitalize them for the economic advantage of the downtown area. City staff has been working with Mr. Baird to assist with the utilities on his property to allow for the properties to be portioned out as single units.

During this process it was discovered that there was an existing sanitary sewer line behind the building without the proper easement and a new easement would be required for the new water line that needs to be installed. In order for the utilities to be in the required and appropriate easement it is the recommendation to enter into an agreement with both Mr. Baird who owns Lots 3, 4, 5 & 6 and Mr. & Mrs. Crouch, who own Lots 1 & 2 for a 20' utility easement on their property.

City staff is working with Kolacny Surveying to complete the metes and bounds exhibits for the agreements to be filed with the County Clerk's office and these are to be provided prior to signatures or filing.

Attached are the draft easement agreements and resolutions to enter into the agreements. The agreements have been reviewed by the City Attorney and meet with their approval. It is my recommendation that the Council consider approving these agreements at this time.

If you should have any questions, please contact me at 979-532-2491 ext. 238. Thank You.

NOTICE OF CONFIDENTIALITY RIGHTS: IF YOU ARE A NATURAL PERSON, YOU MAY REMOVE OR STRIKE ANY OF THE FOLLOWING INFORMATION FROM THIS INSTRUMENT BEFORE IT IS FILED FOR RECORD IN THE PUBLIC RECORDS: YOUR SOCIAL SECURITY NUMBER OR YOUR DRIVER'S LICENSE NUMBER.

UTILITY EASEMENT AGREEMENT

Date: June ____, 2022

Grantor: Justin D. & Kristina D. Crouch
525 CR 164
Boling, Texas 77420

Grantee: City of Wharton
120 E. Caney Street
Wharton, Texas 77488

Consideration: Ten dollars (\$10.00) and the following good and valuable consideration:

Property: A twenty (20) ft. public utility easement, situated in the City of Wharton, in the William Kincheloe League, Abstract No. 38, Wharton County, Texas, Block 1 Lot 1 & 2, of the Baird Subdivision, as per plat thereof, recorded in Slide 3278, of the Plat Cabinet III Records of Wharton County, Texas; said twenty (20) ft. public utility easement being more particularly described by metes and bounds on the attached Exhibit A.

Grant of Utility Easement

1. Grantor hereby grants, sells, and conveys unto Grantee an easement and right-of-way upon and across the above-described property of the Grantor.

Character of Easement

2. The easement granted herein is an easement in gross.

Purpose of Easement

3. The right-of-way, easement, rights, and privileges herein granted shall be used only for the purpose of City sewer, water, or other City utilities.

Duration of Easement

4. The easement, rights, and privileges herein granted shall be perpetual. Grantor hereby bind itself, their successor and assigns, and legal representatives, to warrant and forever defend, the above-described easement and rights unto Grantee, its successors, and assigns, against every person whomsoever lawfully claiming or to claim the same or any part thereof.

Exclusiveness of Easement

5. The easement, rights, and privileges granted herein are exclusive, and Grantor covenants that it will not convey any other easement or conflicting rights within the area covered by this grant.

Encroachments

6. Grantee shall have the right to cut and trim trees or shrubbery which may encroach upon the easement area herein conveyed, and Grantee shall dispose of all cuttings and trimmings by loading and hauling away from the premises.

Termination

7. The easement, rights, and privileges granted hereunder shall terminate when, or at such time, as the purposes hereof cease to exist, are abandoned by Grantee, or become impossible of performance.

Rights Reserved

8. Grantor retains, reserves, and shall continue to enjoy the use of the surface of such property for any and all purposes which do not interfere with and prevent the use by Grantee of the utilities within easement.

Entire Agreement

9. This instrument contains the entire agreement between the parties relating to the rights herein granted and the obligations herein assumed. Any oral representations or modifications concerning this instrument shall be of no force and effect excepting a subsequent modification in writing, signed by the party to be charged.

JUSTIN D. CROUCH

KRISTINA D. CROUCH

OWNER

OWNER

ACCEPTED AND AGREED by the City of Wharton, Texas, this _____ day of June 2022.

CITY OF WHARTON, TEXAS

By: Tim Barker, Mayor

ATTEST:

PAULA FAVORS, City Secretary

Acknowledgments

STATE OF TEXAS §

COUNTY OF WHARTON §

THIS INSTRUMENT was acknowledged before me on the ____ day of June 2022 by JUSTIN D. CROUCH, Owner.

Notary Public, State of Texas

STATE OF TEXAS §

COUNTY OF WHARTON §

THIS INSTRUMENT was acknowledged before me on the ____ day of June 2022 by KRISTINA D. CROUCH, Owner.

Notary Public, State of Texas

STATE OF TEXAS §

COUNTY OF WHARTON §

THIS INSTRUMENT was acknowledged before me on the ____ day of June 2022 by TIM BARKER, Mayor of the CITY OF WHARTON, TEXAS.

Notary Public, State of Texas

NOTICE OF CONFIDENTIALITY RIGHTS: IF YOU ARE A NATURAL PERSON, YOU MAY REMOVE OR STRIKE ANY OF THE FOLLOWING INFORMATION FROM THIS INSTRUMENT BEFORE IT IS FILED FOR RECORD IN THE PUBLIC RECORDS: YOUR SOCIAL SECURITY NUMBER OR YOUR DRIVER'S LICENSE NUMBER.

UTILITY EASEMENT AGREEMENT

Date: June ____, 2022

Grantor: Russell J. Baird
308 W. Milam St.
Wharton, Texas 77488

Grantee: City of Wharton
120 E. Caney Street
Wharton, Texas 77488

Consideration: Ten dollars (\$10.00) and the following good and valuable consideration:

Property: A twenty (20) ft. public utility easement, situated in the City of Wharton, in the William Kincheloe League, Abstract No. 38, Wharton County, Texas, Block 1, Lot 3, 4, 5 & 6, of the Baird Subdivision, as per plat thereof, recorded in Slide 3278, of the Plat Cabinet III Records of Wharton County, Texas; said twenty (20) ft. public utility easement being more particularly described by metes and bounds on the attached Exhibit A.

Grant of Utility Easement

1. Grantor hereby grants, sells, and conveys unto Grantee an easement and right-of-way upon and across the above-described property of the Grantor.

Character of Easement

2. The easement granted herein is an easement in gross.

Purpose of Easement

3. The right-of-way, easement, rights, and privileges herein granted shall be used only for the purpose of City sewer, water, or other City utilities.

Duration of Easement

4. The easement, rights, and privileges herein granted shall be perpetual. Grantor hereby bind itself, their successor and assigns, and legal representatives, to warrant and forever defend, the above-described easement and rights unto Grantee, its successors, and assigns, against every person whomsoever lawfully claiming or to claim the same or any part thereof.

Exclusiveness of Easement

5. The easement, rights, and privileges granted herein are exclusive, and Grantor covenants that it will not convey any other easement or conflicting rights within the area covered by this grant.

Encroachments

6. Grantee shall have the right to cut and trim trees or shrubbery which may encroach upon the easement area herein conveyed, and Grantee shall dispose of all cuttings and trimmings by loading and hauling away from the premises.

Termination

7. The easement, rights, and privileges granted hereunder shall terminate when, or at such time, as the purposes hereof cease to exist, are abandoned by Grantee, or become impossible of performance.

Rights Reserved

8. Grantor retains, reserves, and shall continue to enjoy the use of the surface of such property for any and all purposes which do not interfere with and prevent the use by Grantee of the utilities within easement.

Entire Agreement

9. This instrument contains the entire agreement between the parties relating to the rights herein granted and the obligations herein assumed. Any oral representations or modifications concerning this instrument shall be of no force and effect excepting a subsequent modification in writing, signed by the party to be charged.

RUSSELL J. BAIRD

OWNER

ACCEPTED AND AGREED by the City of Wharton, Texas, this _____ day of June 2022.

CITY OF WHARTON, TEXAS

By: Tim Barker, Mayor

ATTEST:

PAULA FAVORS, City Secretary

Acknowledgments

STATE OF TEXAS §

COUNTY OF WHARTON §

THIS INSTRUMENT was acknowledged before me on the ____ day of June 2022 by RUSSELL J. BAIRD, Owner.

Notary Public, State of Texas

STATE OF TEXAS §

COUNTY OF WHARTON §

THIS INSTRUMENT was acknowledged before me on the ____ day of June 2022 by TIM BARKER, Mayor of the CITY OF WHARTON, TEXAS.

Notary Public, State of Texas

**CITY OF WHARTON
RESOLUTION NO. 2022-XX**

A RESOLUTION OF THE WHARTON CITY COUNCIL ACCEPTING A UTILITY EASEMENT AGREEMENT BETWEEN THE CITY OF WHARTON AND JUSTIN D. & KRISTINA D. CROUCH FOR WILLIAM KINCHELOE LEAGUE, ABSTRACT NO. 38, WHARTON COUNTY, TEXAS, BLOCK 1, LOT 1 & 2, OF THE BAIRD SUBDIVISION AND AUTHORIZING THE MAYOR OF THE CITY OF WHARTON TO EXECUTE SAID AGREEMENT.

WHEREAS, The Wharton City Council wishes to enter into a Utility Easement Agreement with Justin D. & Kristina D. Crouch for William Kincheloe League, Abstract No. 38, Wharton County, Texas, Block 1, Lot 1 & 2, of the Baird Subdivision; and,

WHEREAS, The City of Wharton and Justin D. & Kristina D. Crouch wish to be bound by the conditions as set forth in the said agreements; and,

WHEREAS, The Wharton City Council wishes to authorize the Mayor of the City of Wharton to execute the Utility Easement Agreement with Justin D. & Kristina D. Crouch.

NOW, THEREFORE, BE IT RESOLVED BY THE CITY COUNCIL OF THE CITY OF WHARTON, TEXAS as follows:

Section I. The Wharton City Council hereby authorizes the Mayor of the City of Wharton to execute the Utility Easement Agreement with Justin D. & Kristina D. Crouch for William Kincheloe League, Abstract No. 38, Wharton County, Texas, Block 1, Lot 1 & 2, of the Baird Subdivision.

Section II. The City of Wharton and Justin D. & Kristina D. Crouch are hereby bound by the conditions as set forth in said agreement.

Section III. That this resolution shall become effective immediately upon its passage.

Passed, Approved, and Adopted this 27th day of June 2022.

CITY OF WHARTON, TEXAS

By: _____
TIM BARKER
Mayor

ATTEST:

PAULA FAVORS
City Secretary

**CITY OF WHARTON
RESOLUTION NO. 2022-XX**

A RESOLUTION OF THE WHARTON CITY COUNCIL ACCEPTING A UTILITY EASEMENT AGREEMENT BETWEEN THE CITY OF WHARTON AND RUSSELL J. BAIRD FOR WILLIAM KINCHELOE LEAGUE, ABSTRACT NO. 38, WHARTON COUNTY, TEXAS, BLOCK 1, LOT 3, 4, 5 & 6, OF THE BAIRD SUBDIVISION AND AUTHORIZING THE MAYOR OF THE CITY OF WHARTON TO EXECUTE SAID AGREEMENT.

WHEREAS, The Wharton City Council wishes to enter into a Utility Easement Agreement with Russell J. Baird for William Kincheloe League, Abstract No. 38, Wharton County, Texas, Block 1, Lot 3, 4, 5 & 6, of the Baird Subdivision; and,

WHEREAS, The City of Wharton and Russell J. Baird wish to be bound by the conditions as set forth in the said agreements; and,

WHEREAS, The Wharton City Council wishes to authorize the Mayor of the City of Wharton to execute the Utility Easement Agreement with Russell J. Baird.

NOW, THEREFORE, BE IT RESOLVED BY THE CITY COUNCIL OF THE CITY OF WHARTON, TEXAS as follows:

Section I. The Wharton City Council hereby authorizes the Mayor of the City of Wharton to execute the Utility Easement Agreement with Russell J. Baird for William Kincheloe League, Abstract No. 38, Wharton County, Texas, Block 1, Lot 3, 4, 5 & 6, of the Baird Subdivision.

Section II. The City of Wharton and Russell J. Baird are hereby bound by the conditions as set forth in said agreement.

Section III. That this resolution shall become effective immediately upon its passage.

Passed, Approved, and Adopted this 27th day of June 2022.

CITY OF WHARTON, TEXAS

By: _____
TIM BARKER
Mayor

ATTEST:

PAULA FAVORS
City Secretary

City of Wharton
 120 E. Caney Street
 Wharton, TX 77488

CITY COUNCIL COMMUNICATION

Meeting Date:	6/27/2022	Agenda Item:	Request from The Brooks at Caney Creek for sidewalk replacement on North Richmond Road.
<p>Ms. Laura Clemons, brought the request for sidewalk replacement on North Richmond Road to the City Council on November 8, 2021, where the item was tabled for further information to be provided and brought back to the Council. The information was gathered and brought back to the City Council on November 22, 2021. The Council was provided a quote for the work that was provided by Muhlhausen Construction in the amount of \$4,942.00. The construction of the sidewalk replacement was discussed and it was decided that the City would be responsible to provide ADA compliant sidewalks and that the cost could be impacted. The request was denied by the City Council. At the same meeting the City Council did agree to allow the City Staff to install culverts at the City’s cost once the developer purchased the culverts. The City confirmed with TxDOT on Friday, May 13, 2022, that their Sidewalk Project has a let date of March 2025 for this area. TxDOT is proposing to have sidewalks on both sides of Richmond Road. TxDOT will not replace any existing sidewalks, unless it doesn’t meet ADA guidelines.</p> <p>Ms. Clemons, is requesting that the City once again consider replacing the sidewalk in front of the property along her development. She has provided her own quote for this request.</p> <p>Ms. Clemons, will be present to answer any questions.</p>			
City Manager: Joseph R. Pace		Date: Thursday, June 23, 2022	
Approval: 			
Mayor: Tim Barker			



City of Wharton
Public Works Department
1005 E. Milam Street ° Wharton, TX 77488
Phone (979) 532-2491 ext. 801 ° Fax (979)
531-1744

MEMORANDUM

Date: May 17, 2022
To: Mr. Joseph R. Pace, City Manager
From: Anthony Arcidiacono, Public Works Director
Subject: The Brooks at Caney Creek: Request for sidewalk replacement on North Richmond Road

Ms. Laura Clemons, brought this request to the City Council on November 8, 2021, where the item was tabled for further information to be provided and brought back to the Council. The information was gathered and brought back to the City Council on November 22, 2021. The Council was provided a quote for the work that was provided by Muhlhausen Construction in the amount of \$4,942.00. The construction was discussed and it was decided that the City would be responsible to provide ADA compliant sidewalks and that the cost could be impacted. The request was denied by the City Council. At the same meeting, the City Council did agree to allow the City Staff to install culverts at City cost once the developer purchased the culverts.

We confirmed with TxDOT on Friday, May 13, 2022, on a sidewalk project that has a let date of March 2025 for this area. They are proposing to have sidewalks on both sides of Richmond Road. They will not replace any existing sidewalks, unless it doesn't meet ADA guidelines.

Ms. Clemons, is requesting that the City once again consider replacing the sidewalk in front of the property along her development. She has provided her own quote for this request.

If you have any questions, please contact me at 979-532-2491 Ext. 800. Thank you.



The Brooks at Caney Creek

Item-3.

Request for City to Replace Sidewalk

Request

City replacement of 120' of sidewalk at 309 Richmond Road

Request Made By

David Bowlin, Project Owner

Estimated Cost

\$4,260 - See attached estimate from Total Outdoor Solutions

City of Wharton Public Works Department head, Anthony Arcidiacono, can speak to the estimate previously presented to City Council in comparison with the most recent estimate attained by Mr. Bowlin.

Details

The existing sidewalk is cracked, uneven, and too narrow to be compliant with current sidewalk width standards. Additionally, in May/June during City utility work, sections of the existing sidewalk were cracked by equipment, parts were completely destroyed and sub-standard patching has created a serious pedestrian hazard. See attached photos.

Chapel Creek Investments is constructing 6 houses and a publicly accessible gazebo on the site and Mr. Bowlin is asking the City to replace the existing sidewalk for so that the sidewalk in front of this newly constructed development is safe and connected.

Thank you for your consideration.

Best,

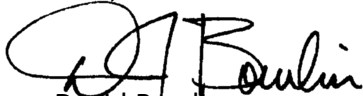

David Bowlin

Owner

Chapel Creek Investments, LLC

DBowlin@A2JHoldings.com

The Brooks at Caney Creek, LLC
3722 Lost Creek Blvd
Austin, TX 78725

(512) 289-2929

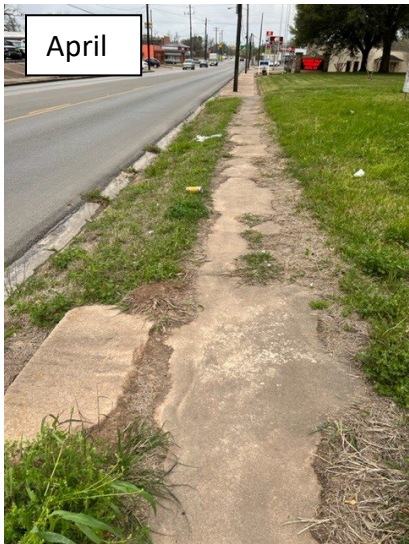



BID

May 11, 2022

Total Outdoor Solutions, LLC
Mark Mata
1825 Foote St.
Wharton, TX. 77488
979-559-6027

Broaddus Construction
Site – 309 N Richmond Ave
Wharton, TX. 77488
Attn: Laura Clemons
laura@ccmc.me
205-789-2266

- *Break out and dispose of existing concrete sidewalk
 - *approx. 3x120
 - *Form and grade new sidewalk 4x120
 - *3/8" rebar, 16" on center
 - *Pour concrete – 3500 psi
 - *Includes city permit
- Labor and Materials

\$4,260.00

This estimate is for completing the job described above based on our evaluation. It does not include unforeseen price increases or additional labor and materials which may be required should problems arise.
50% of balance due before work begins. Remaining balance due upon completion.

City of Wharton
120 E. Caney Street
Wharton, TX 77488

CITY COUNCIL COMMUNICATION

Meeting Date:	6/27/2022	Agenda Item:	Wharton Economic Development Corporation Fiscal Year 2022-2023 Annual Budget.
<p>Attached you will find the Wharton Economic Development Corporation Fiscal Year 2022-2023 Annual Budget.</p> <p>Mr. Josh Owens will be present to answer any questions.</p>			
City Manager: Joseph R. Pace		Date: Thursday, June 23, 2022	
Approval: 			
Mayor: Tim Barker			



Economic Development Corporation
1944 North Fulton Street, Wharton, TX 77488
Phone (979) 532-0999 Fax (979) 532-5257

June 14, 2022

City Manager Joseph R. Pace
120 E. Caney Street
Wharton, TX 77488

RE: Wharton Economic Development Corporation Fiscal Year 2022-2023 Annual Budget.

Dear Mr. Pace,

Attached please find Wharton EDC's FY 2022-2023 Budget approved by the Directors on May 25, 2022.

Please place the Budget on the agenda for your next City Council Meeting for comment, review, consideration and approval.

Please feel free to contact our office if you should have any questions.

Sincerely,

A handwritten signature in black ink, appearing to read "J. Owens", with a stylized flourish at the end.

Joshua Owens, Executive Director

Enclosure

JO/lj

Wharton Economic Development Corporation

FY 22-23 **APPROVED** BUDGET 05-19-2022

FY 2022 Item-4.

<u>Projected Estimated Revenues</u>		APPROVED
51-3210	Sales Tax	825,000
51-3773	Interest on Investments	2,500
51-3778	Property Investments/Misc. Income	4,000
Sub Total Revenues		831,500
General Funds	Draw From Fund Balance(Cash on Hand)	841,733
51-3780	Fund Balance/Loan Proceeds	0
Sub Total General Funds & Fund Balance/Loan Proceeds		841,733
Total Revenues		1,673,233

PROJECTED EXPENDITURES

<u>Program/Project</u>		
51-555-00-661	Property Taxes	7,500
51-555-00-664	Uncommitted Funds	100,000
Mega Projects, Survey and Soil Tests, Architectural and Engineering Studies(under \$5k)		
Option Fee, Studies(under \$5k), Debit Service, Planning, Meeting Expense		
51-555-00-666	Restoration/Demolition Special Projects,	100,000
51-555-00-667	Wharton o6o Local Business Disaster Recovery Loans	57,022
51-555-00-702	City Mapping Support	6,000
51-555-00-707	Tractor Supply Sales Tax Rebate	30,000
51-555-00-709	Projects Requiring Infrastructure	298,197
On Projects, including but not limited to locations for FM 1301, Wharton Industrial Foundation, Outdoor Recreation Facility, Hotel, Airport Manufacutring		
51-555-00-719	Entrance Imporvement Project	33,250
51-555-00-728	Business Retention & Expansion/Business Improvement Grants	400,000
51-555-00-732	Wayfinding Project	15,350
51-555-00-733	FM 1301 Extension Project	150,000
51-555-00-734	Miscellaneous	2,000
Total Program/Project		1,199,319

Marketing

51-557-00-215	Printing & Binding	8,500
51-557-00-218	Office & Grounds	2,500
51-557-00-222	Board Meeting/Director Expense	3,500
51-557-00-290	Miscellaneous (Supplies)	500
51-557-00-520	Business Expense Meals/ Gifts	4,000
51-557-00-522	Meeting Expense	5,500
51-557-00-540	Chamber Programs	25,000
51-557-00-559	Travel Expense	3,500
51-557-00-561	Conferences	20,000
ICSC, Las Vegas, ICSC Red River, TEDC, Annual Conference		
Site Selectors Guild Annual Meeting and Site Selectors Guild Fall Meeting		
51-557-00-562	Contract Marketing/Web Site	15,000
51-557-00-563	SBDC Office Funding/SCORE	12,000
51-557-00-566	Retail Strategies	25,000
51-557-00-689	Downtown Development Promotion & Business Attraction	25,000
51-557-00-690	Miscellaneous	2,000
Total Marketing		152,000

Administration

51-550-00-110	Personnel & Benefits	201,863
51-550-00-122	Vehicle Allowance	9,000
51-554-00-210	Supplies	3,000
51-554-00-211	Postage	700
81-554-00-212	Dues & Subscriptions	7,000
51-554-00-250	Equipment	5,000
51-554-00-524	Phone/Internet	9,000
51-554-00-530	Insurance	6,500
51-554-00-550	Continuing Educaton	6,500
51-554-00-560	Professional Services	55,000
51-554-00-561	City Lease/Acct. Service	14,851
51-554-00-690	Miscellaneous	3,500
Total Administration		321,914

TOTAL EXPENDITURES 1,673,233

2022-2023 Revenues Less Expenditures 0

City of Wharton
 120 E. Caney Street
 Wharton, TX 77488

CITY COUNCIL COMMUNICATION

Meeting Date:	6/27/2022	Agenda Item:	Resolution: A resolution of the Wharton City Council approving an additional three (3) months on the MyGov, LLC Software for the City of Wharton and authorizing the Mayor of the City of Wharton to execute all documents related to said contract.
---------------	-----------	--------------	--

The City Council adopted the Wharton Recovery Plan associated with the implementation of City's ARPA – Coronavirus Local Fiscal Recovery Funds (CLFRF) on April 25, 2022. As part of the plan, one of the approved items was the purchase of a GIS system.

The City Council approved the purchase of the MyGov Software at the Regular Meeting on June 13, 2022, at a cost \$30,970.00. This included the annual cost of \$23,964.00 to be shared over multiple departments after the initial first year and a one-time set up cost of \$7,006.00.

Upon starting the implementation process it was discovered that this would not allow the set up and implementation to begin until October 1, 2022, in order to maintain the contract on the City's fiscal calendar. It is the request of City Staff to approve an additional \$5,991.00, bringing the total expenditure to \$36,961.00 to begin the implementation July 1, 2022. This amount is still well within the allotted amount allocated under the budget in the ARPA-CLFRF Wharton Recovery Plan.

Director of Planning & Development, Gwyn Teves, will be present to answer any questions.

City Manager: Joseph R. Pace	Date: Thursday, June 23, 2022
Approval: 	
Mayor: Tim Barker	



City of Wharton

120 E. Caney • Wharton, TX 77488
Phone (979) 532-2491 • Fax (979) 532-0181

MEMORANDUM

DATE: June 21, 2022
FROM: Gwyneth Teves, Director of Planning & Development
TO: Honorable Mayor and City Council
SUBJECT: American Rescue Plan Act (ARPA) Purchase

The City of Wharton City Council adopted the Wharton Recovery Plan associated with the implementation of City's ARPA – Coronavirus Local Fiscal Recovery Funds (CLFRF) on April 25, 2022. As part of the plan one of the approved items was the purchase of a GIS system.

City Council approved the purchase of the MyGov Software at the June 13th, 2022, Council Meeting at a cost \$30,970.00. This include an annual cost of \$23,964.00 to be shared over multiple departments after the initial first year and a one time set up cost of \$7,006.00.

Upon starting the implementation process it was discovered that this would not allow the set up and implementation to begin until October 1, 2022, in order to maintain the contract on the City's fiscal calendar. It is the request of City staff to approve an additional \$5,991.00, bringing the total expenditure to \$36,961.00 to begin the implementation July 1st. This amount is still well within the allotted amount allocated under the budget in the ARPA-CLFRF Wharton Recovery Plan.

If you should have any questions, please contact me at 979-532-2491 ext. 238. Thank You.



**Building Better
Communities**

Subscription Proposal

Created for City of Wharton, TX

For:

Gwyn Teves
Community Development Director
120 East Caney Street
Wharton, Texas 77488
979-532-2491
gteves@cityofwharton.com

MyGov Contact:

Evan Bachman
Account Executive
P.O. Box 646003
Dallas, TX 75264-6003
(866) 332-4558
ebachman@mygov.us

Pricing

	Price	Years	
ANNUAL SUBSCRIPTION FEES			
Code Enforcement	\$4,788.00	1.25	\$5,985.00
Permits	\$4,788.00	1.25	\$5,985.00
Work Orders	\$4,788.00	1.25	\$5,985.00
Asset Management	\$2,400.00	1.25	\$3,000.00
Credential Manager	\$2,400.00	1.25	\$3,000.00
Electronic Plan Review	\$2,400.00	1.25	\$3,000.00
GIS / Mapping	\$2,400.00	1.25	\$3,000.00
Collaborator Portal	\$0.00	1.25	\$0.00
Public Portal	\$0.00	1.25	\$0.00
Request Manager	\$0.00	1.25	\$0.00
			\$29,955.00
ONE-TIME FEES			
Online Training	\$3,032.00	1	\$3,032.00
Detailed Install (6 Week)	\$3,974.00	1	\$3,974.00
			\$7,006.00
Total of Annual & One-Time Fees			\$36,961.00

**CITY OF WHARTON
RESOLUTION NO. 2022-XX**

A RESOLUTION OF THE WHARTON CITY COUNCIL APPROVING AN ADDITIONAL THREE (3) MONTHS ON THE MYGOV, LLC SOFTWARE FOR THE CITY OF WHARTON AND AUTHORIZING THE MAYOR OF THE CITY OF WHARTON TO EXECUTE ALL DOCUMENTS RELATED TO SAID CONTRACT.

WHEREAS, It is in the best interest of the City of Wharton Personnel and Citizens to purchase and install MyGov, LLC Software, which will allow for online permitting, electronic plan reviews, asset management, GIS/mapping and other modules; and,

WHEREAS, The Wharton City Council has designated the necessary funding for the purchase and installation of said software through the City’s Recovery Plan utilizing the American Rescue Plan Act Funds; and,

WHEREAS, The Wharton City Council wishes to approve additional funding in the amount of \$5,991.00 for an additional three (3) months to the contract for a total price of \$36,961.00 to be used to purchase and install said software; and,

WHEREAS, The Wharton City Council wishes to purchase MyGov, LLC Software; and,

WHEREAS, The Wharton City Council wishes to authorize the Mayor of the City of Wharton to execute any and all documents related to said software’s purchase and installation.

NOW, THEREFORE, BE IT RESOLVED BY THE CITY COUNCIL OF THE CITY OF WHARTON, TEXAS as follows:

Section I. That the Wharton City Council hereby approves the additional funding in the amount of \$5,991.00 for an additional three (3) months to the contract for a total price of \$36,961.00 to purchase and install MyGov, LLC Software.

Section II. That the Mayor of the City of Wharton is hereby authorized to execute any and all documents related to said software’s purchase and installation.

Section III. That this resolution shall become effective immediately upon its passage.

Passed, Approved, and Adopted this 27th day of June 2022.

CITY OF WHARTON, TEXAS

By: _____
TIM BARKER
Mayor

ATTEST:

PAULA FAVORS
City Secretary

City of Wharton
 120 E. Caney Street
 Wharton, TX 77488

CITY COUNCIL COMMUNICATION

Meeting Date:	6/27/2022	Agenda Item:	Resolution: A resolution of the Wharton City Council authorizing the submission of applications to the Texas Department of Emergency Management under the Hazard Mitigation Grant Program – Texas COVID-19 Pandemic DR-4485 on behalf of Wharton Independent School District, entering into a Memorandum of Understanding and authorizing the Mayor to execute all documents relating to said applications and Memorandum of Understanding.
<p>The Wharton Independent School District (ISD) is requesting to that the City of Wharton apply for the Hazard Mitigation Grant Program DR-4485 Texas COVID-19 Grant on behalf of the Wharton ISD as a subrecipient for two (2) applications. The applications would be for mitigation retrofits and generators for their facilities. Wharton ISD would be responsible for any costs not covered by the grant funds. This would be documented by entering into a Memorandum of Understanding with the Wharton Independent School District.</p> <p>Included with this memo, is the letter of request, from Michael J. O’Guin, Sr., ED.D., Superintendent of Wharton ISD, draft Memorandum of Understanding and the draft resolution.</p> <p>Director of Planning & Development, Gwyn Teves, will be present to answer any questions.</p>			
City Manager: Joseph R. Pace		Date: Thursday, June 23, 2022	
Approval: 			
Mayor: Tim Barker			



City of Wharton

120 E. Caney • Wharton, TX 77488
Phone (979) 532-2491 • Fax (979) 532-0181

MEMORANDUM

DATE: June 21, 2022
FROM: Gwyneth Teves, Director of Planning and Development
TO: Honorable Mayor and City Council
SUBJECT: WISD Application Request HMGP-DR-4485 & MOU

The Wharton Independent School District (ISD) is requesting to that the City of Wharton apply for the Hazard Mitigation Grant Program DR-4485 Texas COVID-19 grant on behalf of the Wharton ISD as a subrecipient for 2 applications. The applications would be for mitigation retrofits and generators for facilities. Wharton ISD would be responsible for any costs not covered by the grant funds. This would be documented by entering into a Memorandum of Understanding with the Wharton Independent School District.

Included with this memo is the letter of request from Michael J. O'Guin, Sr., ED.D., Superintendent of Wharton ISD, draft memorandum of understanding and the draft resolution.

If you should have any questions, please contact me at 979-532-2491 ext. 238. Thank You.

MEMORANDUM OF UNDERSTANDING (“MOU”) BETWEEN THE CITY OF WHARTON AND Wharton ISD

WHEREAS, City of Wharton (“City”) applied for one or more federal grants on behalf of the Wharton ISD (“School District”); and

WHEREAS, the City receives an official award determination letter from FEMA for the eligible costs of the Structural Retrofit and Generators (“Project”) through the Hazard Mitigation Grant Program (HMGP); and

WHEREAS, there is a need to formulate the responsibilities of the School District and the City for the management of the Projects;

BE IT THEREFORE AGREED AS FOLLOWS:

The School District will be responsible for costs of the Projects that are not covered by the grant funds.

The School District will be responsible for seeking bids for the management and construction of the Project. The City hereby authorizes the School District to enter into contracts with architects, contractors, consultants and other service providers as necessary for the Project.

The School District will submit invoices and canceled checks to a consultant hired to manage the grant (“Consultant”). The Consultant will compose the reimbursement package, which includes the invoices and canceled checks. The Consultant will then have the City sign the completed reimbursement package.

The City will then forward the package to the Texas Department of Emergency Management (TDEM), which will then be reviewed then forwarded to FEMA for reimbursement. The School District and the City will receive copies of all correspondence, checks, and invoices as submitted to TDEM.

The City will receive reimbursement of funds and will, within 15 days of receipt, issue full reimbursement payment to the School District.

The City acknowledges that it is not claiming any ownership interests in the property and agrees to sign any documents necessary to convey title to the Non-profit.

The School District acknowledges that the City is not financially responsible for the Project nor will the City be liable for any future claims or damages that may result from the Project. The City is named on the Project only for the purposes of eligibility to apply to the grant.

IN WITNESS WHEREOF, the City and School District hereto have caused this MOU to be duly executed on the day and year first above written.

City of Wharton, Texas

Wharton ISD

BY: _____

BY: _____

NAME: _____

NAME: _____

TITLE: _____

TITLE: _____

DATE: _____

DATE: _____

DRAFT



Dr. Michael O'Guin, Sr. Ed.D.
Superintendent of Schools

Item-6.

WHARTON INDEPENDENT SCHOOL DISTRICT
2100 N. Fulton • Wharton, Texas • 77488
979.532.3612

June 7, 2022

Tim Barker, Mayor
City of Wharton
120 East Caney Street
Wharton, Texas 77488

Re: Wharton Independent School District's request for City of Wharton support in applying to FEMA's Hazard Mitigation Grant Program

Dear Mayor Barker,

The Wharton Independent School District is respectfully requesting the support of the City of Wharton in the School's effort to apply to the Hazard Mitigation Grant Program that is currently accepting grant applications (HMGP-DR-4485).

The City of Wharton would have only a few action items, including requesting access to the two application types (generator and retrofit) within the existing TDEM GMS account, sign the standard federal grant application forms, and sign and submit the two grant applications once completed on June 28, 2022.

A Memorandum of Understanding between the City and the School District can be provided for your review as well as anything else that is needed.

The School District appreciates your consideration of providing this support. Please contact me with any questions.

Thank you,

Michael J. O'Guin, Sr., Ed.D.
Superintendent

**CITY OF WHARTON
RESOLUTION NO. 2022-XX**

A RESOLUTION OF THE WHARTON CITY COUNCIL AUTHORIZING THE SUBMISSION OF APPLICATIONS TO THE TEXAS DEPARTMENT OF EMERGENCY MANAGEMENT UNDER THE HAZARD MITIGATION GRANT PROGRAM – TEXAS COVID-19 PANDEMIC DR-4485 ON BEHALF OF WHARTON INDEPENDENT SCHOOL DISTRICT, ENTERING INTO A MEMORANDUM OF UNDERSTANDING AND AUTHORIZING THE MAYOR TO EXECUTE ALL DOCUMENTS RELATING TO SAID APPLICATIONS AND MEMORANDUM OF UNDERSTANDING.

WHEREAS, On December 10, 2021, the United States President declared a major disaster (DR-4485) as a result of the Texas COVID-19 Pandemic which established the statewide availability of the Hazard Mitigation Grant Program (HMGP); and,

WHEREAS, The City of Wharton City Staff requests to issue applications for retrofits and generators on behalf of Wharton Independent School District under DR-4485 and is seeking City Council permission for the submission of the applications; and,

WHEREAS, The City of Wharton and Wharton Independent School District would execute a Memorandum of Understanding agreeing that the Wharton Independent School District would be responsible for all associated costs not covered by the grant; and,

WHEREAS, The City of Wharton and the Wharton Independent School District wish to be bound by the terms of the Memorandum of Understanding; and,

WHEREAS, The Wharton City Council wishes to authorize the City Staff submit the applications on behalf of Wharton Independent School District.

NOW, THEREFORE, BE IT RESOLVED BY THE CITY COUNCIL OF THE CITY OF WHARTON, TEXAS;

Section I: That the Wharton City Council hereby approves the City Staff to submit applications under the Texas Department of Emergency Management Hazard Mitigation Grant Program (DR-4485) Texas COVID-19 Pandemic on behalf of Wharton Independent School District.

Section II: That the City of Wharton and the Wharton Independent School District wish to be bound by the terms of the Memorandum of Understanding.

Section III. The Wharton City Council hereby authorizes the Mayor to execute all documents relating to the grant applications and execute the Memorandum of Understanding with the Wharton Independent School District.

Section IV: That this resolution shall take effect immediately upon its passage.

PASSED, APPROVED AND ADOPTED this 27th day of June 2022.

CITY OF WHARTON, TEXAS

By: _____
TIM BARKER
Mayor

ATTEST:

PAULA FAVORS
City Secretary

DRAFT

City of Wharton
 120 E. Caney Street
 Wharton, TX 77488

CITY COUNCIL COMMUNICATION

Meeting Date:	6/27/2022	Agenda Item:	Resolution: A resolution of the Wharton City Council ratifying a Facilities Extension Agreement with CenterPoint Energy for Utility Service on C.R. 222 for the Wharton Water Well Project and authorizing the Mayor of the City of Wharton to execute the agreement.
<p>The City of Wharton has been working with CenterPoint Energy to supply new service to water well being constructed on CR 222. The addition of these facilities per CenterPoint Energy’s estimate will be \$17,920.00. The cost covers the installation of services outside the facilities extension agreement and overhead work as required.</p> <p>The City Council approved the easement to place utilities on June 13, 2022, and would have been presented these documents at the same time if received prior to submission of the easement documents. However, to not delay the installation of the utilities, the Facilities Extension Agreement and Rut Letter Agreement were executed at the time of the easement documentation and the City Staff is requesting that these documents be ratified at this time.</p> <p>Attached are the Facilities Extension Agreement, Rut Letter Agreement and Draft Resolution.</p> <p>Director of Planning & Development, Gwyn Teves, will be present to answer any questions.</p>			
City Manager: Joseph R. Pace		Date: Thursday, June 23, 2022	
Approval: 			
Mayor: Tim Barker			



City of Wharton

120 E. Caney • Wharton, TX 77488
Phone (979) 532-2491 • Fax (979) 532-0181

MEMORANDUM

DATE: June 20, 2022
FROM: Gwyneth Teves, Director of Planning & Development
TO: Honorable Mayor and City Council
SUBJECT: CR 222 Water Well CenterPoint Facilities Extension Agreement for new service

The City of Wharton has been working with CenterPoint Energy to supply new service to water well being constructed on CR 222.

The addition of these facilities per CenterPoint Energies estimate will be \$17,920.00. The cost covers the installation of services outside the facilities extension agreement and overhead work as required.

The City Council approved the easement to place utilities on 06/13/2022 and would have been presented these documents at the same time if received prior to submission of the easement documents. However, to not delay the installation of the utilities the Facilities Extension Agreement and Rut Letter Agreement were executed at the time of the easement documentation and City staff is requesting that these documents be ratified at this time.

Attached are the Facilities Extension Agreement, Rut Letter Agreement and Draft Resolution. It is my recommendation to approve at this this time to not delay the project.

If you should have any questions, please contact me at 979-532-2491 ext. 238. Thank You.

Chapter 6: Company Specific Items

Sheet No. 6.24
Page 1 of 2CenterPoint Energy Houston Electric, LLC
Applicable: Entire Service Area

CNP 8038

6.3 AGREEMENTS AND FORMS**6.3.1 FACILITIES EXTENSION AGREEMENT**

This Facilities Extension Agreement is entered into by and between _____, herein called "Retail Customer" and CenterPoint Energy Houston Electric, LLC, herein called "Company" (hereinafter referred to as Agreement) for the construction, extension, installation, modification, repair, upgrade, conversion, relocation, de-energization or removal of Company's Delivery System, including temporary facilities (hereinafter referred to as facilities extension or extension), as described herein.

This Agreement covers the facilities extension to Retail Customer location at _____
240 CR 222, Wharton Tx 77488

The Company agrees to accept payment of 17,920.00 Dollars to be paid by the Retail Customer, as a Non-Refundable Construction Payment in connection with the Retail Customer request to extend Company facilities to the above described location as follows: Installation of services outside of line extension agreement.

Overhead work depicted in Sheet 9 of 14 in Terms and Conditions packet

WO: 102364216

- Unless otherwise stated by Company in writing, the Non-Refundable Construction Payment amount above is valid for twelve months.

In consideration of said Non-Refundable Payment, to be paid to Company by Retail Customer prior to commencement of construction, Company agrees to install and operate lines and equipment necessary to distribute electric service to the identified location under the following General Conditions:

- Company shall at all times have title to and complete ownership and control over facilities installed by Company.
- Retail Customer must make satisfactory payment arrangements (if payment is required to extend Company facilities) and sign and return this Agreement before Company can proceed with the requested extension.

Chapter 6: Company Specific Items

Sheet No. 6.24
Page 2 of 2

CenterPoint Energy Houston Electric, LLC
Applicable: Entire Service Area

CNP 8038

- Extension of service facilities is contingent on acquisition of all necessary easements and rights of way.

Nothing herein contained within this Agreement shall be construed as a waiver or relinquishment by Company of any right that it has or may hereafter have to discontinue service for or on account of default in the payment of any bill owing or to become owing thereafter for any other reason or cause stated in Company's Tariff.

This Agreement shall not be binding upon Company unless and until it is signed by an authorized representative of the Company.

CenterPoint Energy Houston Electric, LLC

City of Wharton
Retail Customer

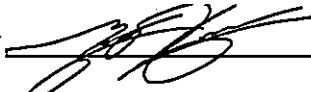
By 
Zachary Henson
(name printed or typed)

By 
Tim Barker
(name printed or typed)

Title Sr. Service Consultant

Title Mayor

Date 03/30/2022

Date 6/13/2022



Please make check payable to:
CenterPoint Energy

Attn: FTB PAC
4011 Avenue H.
Rosenberg, Tx 77471

INVOICE

Customer Info:

6/8/22

Name:	City of Wharton				
Address:	240 CR 222				
City:	Wharton	State:	Tx	ZIP	77488
Phone:					
Email:					
CNP Representative:	Zachary Henson				281-341-4909

	Description	W/O #	Total
1	In Aid of Construction	102364216	\$ 17,920.00
2			
3			
4			
5			
			\$17,920.00

PLEASE MAIL PAYMENT TO THE ABOVE ADDRESS.
Processing of check may be delayed without the return of this invoice.

Make all checks payable to: *CenterPoint Energy*

Please send a copy of this invoice along with the check. Charges good for 1 year from date of invoice.

Payment is required prior to release of construction work order

If you have any questions concerning this invoice, please contact your CNP Representative at number above.

Thank you for using CenterPoint Energy



Rut Letter Agreement

Date: 3/30/2022

Fort Bend Service Center
4011 Avenue H
Rosenberg, TX; 77471

Dear CenterPoint Energy Customer:

Providing electrical service to your address in a timely manner is important to me and to our company. CenterPoint Energy Houston Electric, LLC (CenterPoint Energy) construction crews and/or our contractors will be doing construction on your Property at your request, as per the Service Outlet Location. While doing this construction, it may be necessary for large machinery, equipment and/or vehicles to enter the Property at the location designated below. Although this equipment is often heavy, CenterPoint Energy will make every effort to minimize ruts or damage to the Property. Unfortunately, the current condition of the Property makes it likely that ruts or damage will occur. CenterPoint Energy would normally defer construction until the Property is in a condition to properly support its vehicles and equipment, and would not proceed with construction under the current conditions without being fully released and indemnified should damage to the Property occur.

By electing below to proceed with construction under conditions that may cause ruts or damage to the Property, the Customer signing below agrees to **release, protect, indemnify, and hold CenterPoint Energy, its affiliates, officers, employees and contractors free and harmless from and against any and all claims, demands, causes of actions, suits, damages to property or other litigation (including all costs thereof and attorney's fees) (the Damages) of any kind and character arising in favor of any person(s), where such Damages are caused by or arise out of the construction activities of CenterPoint Energy employees or contractors upon the Property, and even where the damages are alleged to be caused by the negligence of CenterPoint Energy or its contractors.**

Please indicate your preference by initialing one of the following choices:

- dh CenterPoint Energy can proceed with the construction under current conditions that may cause ruts or damage to the Property.
- OR
- _____ CenterPoint Energy may delay construction until the Property is in a condition to properly support its vehicles and/or the equipment necessary for construction.

Please return this form to me at your earliest convenience at the above address or fax to (281) 341-4991, or feel free to call me at (281) 341-4909 with any questions you might have.

Sincerely,

Zachary Henson
Service Consultant
Fort Bend Service Center

Customer*: Dr Barker Date: 0-13-22
 Print Name: Tim Barker Title: Mayor
 Construction Address (the Property): 240 CR 222

*If the person signing this Agreement is not the Owner of the Property, that Person must be authorized by the Owner to sign the Agreement.

**CITY OF WHARTON
RESOLUTION NO. 2022-XX**

A RESOLUTION OF THE WHARTON CITY COUNCIL RATIFYING A FACILITIES EXTENSION AGREEMENT WITH CENTERPOINT ENERGY FOR UTILITY SERVICE ON C.R. 222 FOR THE WHARTON WATER WELL PROJECT AND AUTHORIZING THE MAYOR OF THE CITY OF WHARTON TO EXECUTE THE AGREEMENT.

WHEREAS, The Wharton City Council wishes to ratify and authorize CenterPoint Energy to install electrical utilities on CR 222 for the Wharton Water Well Project; and,

WHEREAS, The Wharton City Council and CenterPoint Energy wishes to be bound by the terms and conditions as outlined in the agreement; and,

WHEREAS, The Wharton City Council wishes to ratify and approve the City Staff to remit payment to CenterPoint Energy in the amount of \$17,920.00 for the cost to install the services; and,

WHEREAS, The Wharton City Council wishes to authorize the Mayor of the City of Wharton to execute all documents related to said agreement.

NOW, THEREFORE, BE IT RESOLVED BY THE CITY COUNCIL OF THE CITY OF WHARTON, TEXAS as follows:

Section I. That the Wharton City Council hereby ratifies and approves the Facilities Extension Agreement between the City of Wharton and CenterPoint Energy for the installation of electrical utilities on CR 222 for the Wharton Water Well Project.

Section II. The Wharton City Council hereby approves the City Staff to remit payment in the amount of \$17,920.00 to CenterPoint Energy to provide the service.

Section III. That the City of Wharton and CenterPoint Energy are hereby bound by the terms and conditions as set forth in the agreement.

Section IV. The Wharton City Council hereby authorizes the Mayor to execute all documents related to the change order.

Section V. That this resolution shall become effective immediately upon its passage.

Passed, Approved, and Adopted this 27th day of June 2022.

CITY OF WHARTON, TEXAS

By: _____
TIM BARKER
Mayor

ATTEST:

PAULA FAVORS
City Secretary

City of Wharton
120 E. Caney Street
Wharton, TX 77488

CITY COUNCIL COMMUNICATION

Meeting Date:	6/27/2022	Agenda Item:	Resolution: A resolution of the Wharton City Council approving an Encroachment Agreement with W. A. Harrison Agriculture, LTD., for a fence encroachment on Tract 224 of the Wharton Levee Project; and authorizing the Mayor of the City of Wharton to execute said agreement.
<p>The City of Wharton purchased property from W. A. Harrison Agriculture, LTD., for the Wharton Levee Project and due to this acquisition, a fence is having to be relocated between the new property lines.</p> <p>City Attorney Paul Webb and City Staff met with a representative of the property and discussed a small area of conflict where the new fence would be impeded by trees. Several methods of remedy were discussed to allow for as little financial or time impacts as possible. It was determined that allowing a 4' fence encroachment at one location would make this transition more feasible.</p> <p>Director of Planning & Development, Gwyn Teves, will be present to answer any questions.</p>			
City Manager: Joseph R. Pace		Date: Thursday, June 23, 2022	
Approval: 			
Mayor: Tim Barker			



City of Wharton

120 E. Caney • Wharton, TX 77488
Phone (979) 532-2491 • Fax (979) 532-0181

MEMORANDUM

DATE: June 21, 2022

FROM: Gwyneth Teves, Director of Planning & Development

TO: Honorable Mayor and City Council

SUBJECT: Recommendation for approval of Encroachment Agreement with W.A. Harrison Agriculture, LTD. for 4' fence on Tract 224 of the Wharton Levee Project

The City of Wharton purchased property from W. A. Harrison Agriculture, LTD. for the Wharton Levee Project and due to this acquisition, a fence is having to be relocated between the new property lines.

City Attorney Paul Webb and I met with a representative of the property and discussed a small area of conflict where the new fence would be impeded by trees. Several methods of remedy were discussed to allow for as little financial or time impacts as possible. It was determined that allowing a 4' fence encroachment at 1 location would make this transition more feasible.

It is my recommendation that this encroachment agreement be approved by the City Council. Attached are the draft agreement with exhibits and draft resolution.

If you should have any questions, please contact me at 979-532-2491 ext. 238. Thank You.

STATE OF TEXAS

COUNTY OF WHARTON

ENCROACHMENT AGREEMENT

THIS ENCROACHMENT AGREEMENT is made this ___ day of July, 2022, between the CITY OF WHARTON, TEXAS (CITY) and W.A. HARRISON AGRICULTURE LTD, a Texas limited partnership (OWNER).

RECITALS

OWNER is the owner of certain property (PROPERTY) located in the City of Wharton described in Exhibit "A" attached hereto.

CITY owns or exercises jurisdiction and control over PROPERTY that is contiguous to such property and which is more particularly described in Exhibit "B" attached hereto.

OWNER desires to place the following described improvements within the public property described above: move the fence line that is to be constructed four (4) feet to encroach on to City of Wharton property, see Exhibit "C" (cross hatch) attached hereto and made a part hereof.

DRAFT

NOW, THEREFORE, be it mutually agreed as follows:

1. Consent to Encroachment. Subject to the terms of this Agreement, CITY hereby consents and allows OWNER to enter upon the above-described CITY property for the purpose of installing, placing and maintaining the above described improvements on the City of Wharton property.

2. Term. This Agreement shall have an indefinite term and shall continue in effect until terminated in accordance with this Agreement.

3. No Interest in Land Conveyed. This Agreement does not constitute a conveyance of any interest in land. CITY retains full rights of possession and control over the above described property, and with respect to such encroachment W.A. HARRISON AGRICULTURE LTD shall have the status of a tenant at will.

4. Conditions. Prior to any construction on the public property the OWNER shall obtain all other licenses or permits necessary for the construction of the improvements. Except in emergencies the OWNER must notify CITY's Department of Public Works at least twenty-four hours in advance of excavating within the easement or right-of-way. OWNER must also comply with all "dial before you dig" requirements.

OWNER shall be solely responsible for maintenance of the improvements and shall maintain them so as to avoid any damage to or interference with CITY facilities, other public utilities or the general right of the public to utilize the property for its intended purpose.

CITY shall not be responsible to OWNER or any other party for damages to OWNER'S improvements. CITY may, at any time upon reasonable notice, require the removal or relocation of the encroaching improvements. OWNER shall relocate the improvements promptly at its sole expense and shall not be entitled to compensation or damages of any kind.

5. Notices. Any notice required or permitted under this Agreement shall be deemed sufficient if delivered in hand or by First Class US Mail addressed to the parties as follows:

CITY
City Manager
120 E. Caney
Wharton, Texas 77488

OWNER
W.A. HARRISION AGRICULTURE LTD

6. Indemnity. OWNER shall indemnify, defend and hold harmless the CITY, its elected officials, officers and employees, from any claims, suits, causes of action, costs or damages arising from OWNER'S action or inaction relating to placement, operation or maintenance of the improvements.



7. Entire Agreement. This Agreement contains the entire agreement between the parties hereto. No promise, representation, warranty or covenant not included in this Agreement has been or is relied on by any party hereto.

8. Construction and Venue. This Agreement shall be construed in accordance with the laws of the State of Texas. Exclusive venue over any claim or cause of action hereunder shall be in the district court of Wharton County, Texas.

9. Termination. This Agreement may be terminated by either party upon thirty days written notice to the other. In the event of termination the OWNER shall promptly remove the encroachments.

10. Agreement a Covenant Running With the Land. This Agreement shall be recorded in the Real Property Records of Wharton County, Texas and shall be a covenant running with the OWNER'S land and binding upon the OWNER'S successors and assigns.

CITY

By: _____
Name: CITY OF WHARTON,
Tim Barker
Title: Mayor

OWNER

By: _____
Name: W.A. Harrison Agriculture LTD
Leonean Harrison
Title: Manager

STATE OF TEXAS

COUNTY OF WHARTON

This instrument was acknowledged before me on July ____, 2022, by Tim Barker, Mayor of CITY OF WHARTON.

Notary Public, State of Texas

STATE OF TEXAS

COUNTY OF WHARTON

DRAFT

This instrument was acknowledge before me on July ____, 2022, by Leonean Harrison, Manager of W.A. HARRISON AGRICULTURE LTD., a Texas Limited Partnership.

Notary Public, State of Texas

After Recording Return to:
City of Wharton
120 E. Caney
Wharton, Texas 77488

Being a 47.53 acre tract of land, situated partially in the William Kincheloe Survey, Abstract 38 and partially in the Alexander Jackson Survey, Abstract 34, Wharton County, Texas, being a portion of a 22.8021 acre tract of land and a portion of a 35.3465 acre tract of land, said 47.53 acre tract being more particularly described as follows:

BEGINNING, at a 3/4 inch diameter iron pipe found for the southeast corner of the herein described tract and said 35.3465 acre tract, also being the southwest corner of a 13.62 acre tract of land conveyed to Lex and Stacey Forgason, dated March 26, 2012, as recorded in Volume 882, Page 531 of the O.R.W.C.T., said iron pipe being on the currently occupied northeast right-of-way line of Spanish Camp Road (variable width right-of-way);

THENCE, with the southwest line of said 35.3465 acre tract, said 22.8021 acre tract and said currently occupied northeast right-of-way line of Spanish Camp Road the following 5 courses:

North 73 deg. 14 min. 29 sec. West, a distance of 484.01 feet to a fence post found for an angle point of the herein described tract;

North 72 deg. 50 min. 06 sec. West, a distance of 316.26 feet to a fence post found for an angle point of the herein described tract; **DRAFT** of a curve to the right;

With said curve to the right having a radius of 176.87 feet, a length of 171.36 feet, a delta of 55 deg. 30 min. 34 sec. and a chord bearing and distance of North 39 deg. 10 min. 52 sec. West, 164.73 feet to a fence post found for an angle point of the herein described tract;

North 07 deg. 26 min. 56 sec. West, a distance of 145.96 feet to a fence post found for an angle point of the herein described tract;

North 15 deg. 32 min. 59 sec. West, a distance of 83.92 feet to a fence post found for an angle point of the herein described tract;

THENCE, crossing said 22.8021 acre tract the following 3 courses:

North 18 deg. 58 min. 31 sec. East, a distance of 423.87 feet to a set 5/8 inch diameter iron rod with yellow plastic cap stamped "CIVILCORP" set for an angle point of the herein described tract;

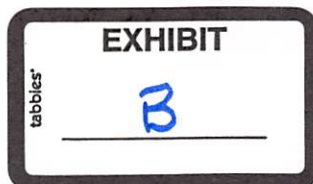

North 14 deg. 58 min. 52 sec. West, a distance of 399.22 feet to a 5/8 inch diameter iron rod with yellow plastic cap stamped "CIVILCORP" set for an angle point of the herein described tract;

North 18 deg. 58 min. 31 sec. East, a distance of 896.38 feet to a 5/8 inch diameter iron rod with yellow plastic cap stamped "CIVILCORP" set for the North corner of the herein described tract, and in the South line of a 3.472 acre tract, described as "Tract 2," conveyed to City of Wharton by Deed, dated July 25, 2000, as recorded in Volume 377, Page 358 of the O.R.W.C.T.;

THENCE, with the North line of said 22.8021 acre tract and said 35.3465 acre tract and the South line of said 3.472-acre tract the following 2 courses:

South 71 deg. 57 min. 22 sec. East, a distance of 32.91 feet to a 5/8 inch diameter iron rod with yellow plastic cap stamped "CIVILCORP" set for an angle point of the herein described tract;

South 72 deg. 01 min. 49 sec. East, a distance of 1,191.87 feet to a 5/8 inch diameter iron rod with yellow plastic cap stamped "CIVILCORP" set for the northeast corner of the herein described tract and in the West right-of-way line of Stafford Lane (50' right-of-way), said iron rod also being in the East line

DRAFT

THENCE, South 17 deg. 28 min. 26 sec. west, with the common line of said 35.3465 acre tract and said West right-of-way line of Stafford Lane and the East line of "Harrison Lane", a distance of 873.63 feet to a 1/2 inch diameter iron rod with plastic cap stamped "RPLS 5319" found for an exterior corner of the herein described tract, and the northeast corner of a 3.09 acre tract conveyed to Garland Mann, dated June 17, 2020, as recorded in Volume 1176, Page 488 of said O.R.W.C.T.;

THENCE, with the common line of said 35.3465 acre tract and said 3.09 acre tract, the following 3 courses:

North 75 deg. 09 min. 10 sec. West, a distance of 166.92 feet to a 5/8 inch diameter iron rod found for an interior corner of the herein described tract;

South 16 deg. 49 min. 49 sec. West, a distance of 822.29 feet to a 5/8 inch diameter iron rod with plastic cap stamped "RPLS 4652" for an interior corner of the herein described tract;

South 69 deg. 39 min. 49 sec, East, a distance of 157.70 feet to a 5/8 inch diameter iron rod with plastic cap stamped "RPLS 5319" for an exterior corner of the herein described tract, the southeast corner of said 3.09 acre tract, and in the West line of said 13.62 acre tract;

THENCE, South 17 deg. 28 min. 26 sec. West, with the common line of said 35.3465 acre tract and said 13.62 acre tract, a distance of 220.15 feet to the **POINT OF BEGINNING** of the herein described tract, containing 47.53 acres of land.

EXHIBIT
tabbles
 B

NOTES:
 1. ALL BEARINGS AND COORDINATES SHOWN HEREON ARE BASED ON THE TEXAS COORDINATE SYSTEM, SOUTH CENTRAL ZONE (4204), NAD83. ALL COORDINATES AND DISTANCES SHOWN HEREON ARE SURFACE AND MAY BE CONVERTED TO GRID BY DIVIDING BY A COMBINED ADJUSTMENT FACTOR OF 1.00013.

2. A PROPERTY DESCRIPTION OF EVEN DATE WAS PREPARED IN CONJUNCTION WITH THIS PARCEL PLAT.

3. THE BOUNDARY LINE ALONG THE COLORADO RIVER IS DEFINED BY THE GRADIENT BOUNDARY, FOR PURPOSES OF THIS SURVEY, THE HIGH BANK WAS UTILIZED FOR AREA CALCULATION.

4. ALL IMPROVEMENTS SHOWN ARE PROVIDED BY OTHERS FOR REFERENCE ONLY AND DO NOT REPRESENT AN ON THE GROUND SURVEY.

5. RECORD TITLE SEARCH PERFORMED AND PROVIDED BY MID-COAST TITLE COMPANY, INC., GF NO. 2019-0757



- SCHEDULE B:
- 10C. EASEMENT TO HOUSTON LIGHTING AND POWER RECORDED IN VOLUME 323, PAGE 534, DEED RECORDS OF WHARTON COUNTY, TEXAS - BLANKET
 - 10D. EASEMENT TO HUMBLE PIPE LINE CO. RECORDED IN VOLUME 84, PAGE 602, DEED RECORDS OF WHARTON COUNTY, TEXAS - DOES NOT AFFECT TRACT
 - 10E. EASEMENT TO WHARTON COUNTY, RECORDED IN VOLUME 146, PAGE 54, DEED RECORDS OF WHARTON COUNTY, TEXAS - DOES NOT AFFECT TRACT
 - 10F. EASEMENT TO HOUSTON LIGHTING AND POWER RECORDED IN VOLUME 377, PAGE 548, DEED RECORDS OF WHARTON COUNTY, TEXAS - AS SHOWN
 - 10G. EASEMENT TO NATURAL GAS PIPELINE CO. RECORDED IN VOLUME 549, PAGE 135, DEED RECORDS OF WHARTON COUNTY, TEXAS - NOT PLOTTABLE
 - 10H. EASEMENT TO HOUSTON LIGHTING AND POWER RECORDED IN VOLUME 282, PAGE 280, OFFICIAL RECORDS OF WHARTON COUNTY, TEXAS - DOES NOT AFFECT TRACT

- LEGEND**
- FOUND MONUMENT (AS NOTED)
 - SET 5/8" IRON ROD WITH YELLOW PLASTIC CAP STAMPED "CIVILCORP"
 - △ CALCULATED POINT
 - R.O.W. RIGHT-OF-WAY
 - P.L. PROPERTY LINE
 - L.H. LAND HOOK
 - D.R.W.C.T. DEED RECORDS WHARTON COUNTY, TEXAS
 - O.R.W.C.T. OFFICIAL RECORDS WHARTON COUNTY, TEXAS
 - P.O.C. POINT OF COMMENCING
 - P.O.B. POINT OF BEGINNING
 - (NXX°XX'XX"E XXX.XX") RECORD BEARING & DISTANCE
 - EXISTING EASEMENT
 - SURVEY LINE
 - EXISTING RIGHT OF WAY
 - PROPOSED TRACT BOUNDARY



EXHIBIT
C

I HEREBY CERTIFY THIS SURVEY WAS PERFORMED ON THE GROUND AND THIS PLAT CORRECTLY REPRESENTS THE FACTS FOUND AT THE TIME OF THE SURVEY, SEPTEMBER 2019.

Brandon Absher
 BRANDON M. ABSHER RPLS#6654

CivilCorp
 ENGINEERS & SURVEYORS
 4811 AIRLINE ROAD, SUITE 300, VICTORIA, TEXAS 77904
 TPC REGISTRATION #1-1093 TPLS REGISTRATION #100378-00

TRACT 224A PAGE 6 OF 7

**CITY OF WHARTON
RESOLUTION NO. 2022-XX**

A RESOLUTION OF THE WHARTON CITY COUNCIL APPROVING AN ENCROACHMENT AGREEMENT WITH W. A. HARRISON AGRICULTURE, LTD., FOR A FENCE ENCROACHMENT ON TRACT 224 OF THE WHARTON LEVEE PROJECT; AND AUTHORIZING THE MAYOR OF THE CITY OF WHARTON TO EXECUTE SAID AGREEMENT.

WHEREAS, The Wharton City Council wishes approve an encroachment agreement with W. A. Harrison Agriculture, LTD., for a 4' fence encroachment on Tract 224 of the Wharton Levee Project, also known as: William Kincheloe Survey, Abstract 38 & Alexander Jackson Survey, Abstract 34; and,

WHEREAS, The City of Wharton and W. A. Harrison Agriculture, LTD., wish to be bound by the conditions as set forth in said agreement; and,

WHEREAS, The Wharton City Council wishes to authorize the Mayor of the City of Wharton to execute all documents related to said agreement.

NOW, THEREFORE, BE IT RESOLVED BY THE CITY COUNCIL OF THE CITY OF WHARTON, TEXAS as follows:

Section I. The Wharton City Council hereby approves an encroachment agreement with W. A. Harrison Agriculture, LTD., for a 4' fence encroachment on Tract 224 of the Wharton Levee Project, also known as: William Kincheloe Survey, Abstract 38 & Alexander Jackson Survey, Abstract 34.

Section II. That the Wharton City Council hereby authorizes the Mayor of the City of Wharton to execute the agreement.

Section III. That this resolution shall become effective immediately upon its passage.

Passed, Approved, and Adopted this 27th day of June 2022.

CITY OF WHARTON, TEXAS

By: _____
TIM BARKER
Mayor

ATTEST:

PAULA FAVORS
City Secretary

City of Wharton
120 E. Caney Street
Wharton, TX 77488

CITY COUNCIL COMMUNICATION

Meeting Date:	6/27/2022	Agenda Item:	Resolution: A resolution of the Wharton City Council authorizing and approving Change Order No. 2 with Arandas Industries for the Wharton Colorado River Flood Control Public Utility Abandonment – Hughes Street and authorizing the Mayor to execute all documents related to said Change Order.
---------------	-----------	--------------	--

Attached is the Wharton Colorado River Flood Control Public Utility Abandonment-Hughes Street Change Order #2 from Arandas Industries for the addition of two (2) storm manholes due to existing conflict on current line. Attached is a copy of the change order for review.

Director of Planning & Development, Gwyn Teves, will be present to answer any questions.

City Manager: Joseph R. Pace	Date: Thursday, June 23, 2022
Approval: 	
Mayor: Tim Barker	



City of Wharton

120 E. Caney • Wharton, TX 77488
Phone (979) 532-2491 • Fax (979) 532-0181

MEMORANDUM

DATE: June 21, 2022

FROM: Gwyneth Teves, Director of Planning & Development

TO: Honorable Mayor and City Councilmembers, City Manager Joseph R. Pace, and City Attorney Paul Webb

SUBJECT: Wharton Colorado River Flood Control Public Utility Abandonment – Hughes St. - Change Order #2

Attached please find the Wharton Colorado River Flood Control Public Utility Abandonment-Hughes St - Change Order #2 from Arandas Industries for the addition of 2 storm manholes due to existing conflict on current line. Attached is a copy of the change order for review.

It is the recommendation of the engineering consultant and City staff that the Council approve the change order for the additional manholes at a cost of \$15,946.

If you should have any questions, please contact me at 979-532-2491. Thank You.

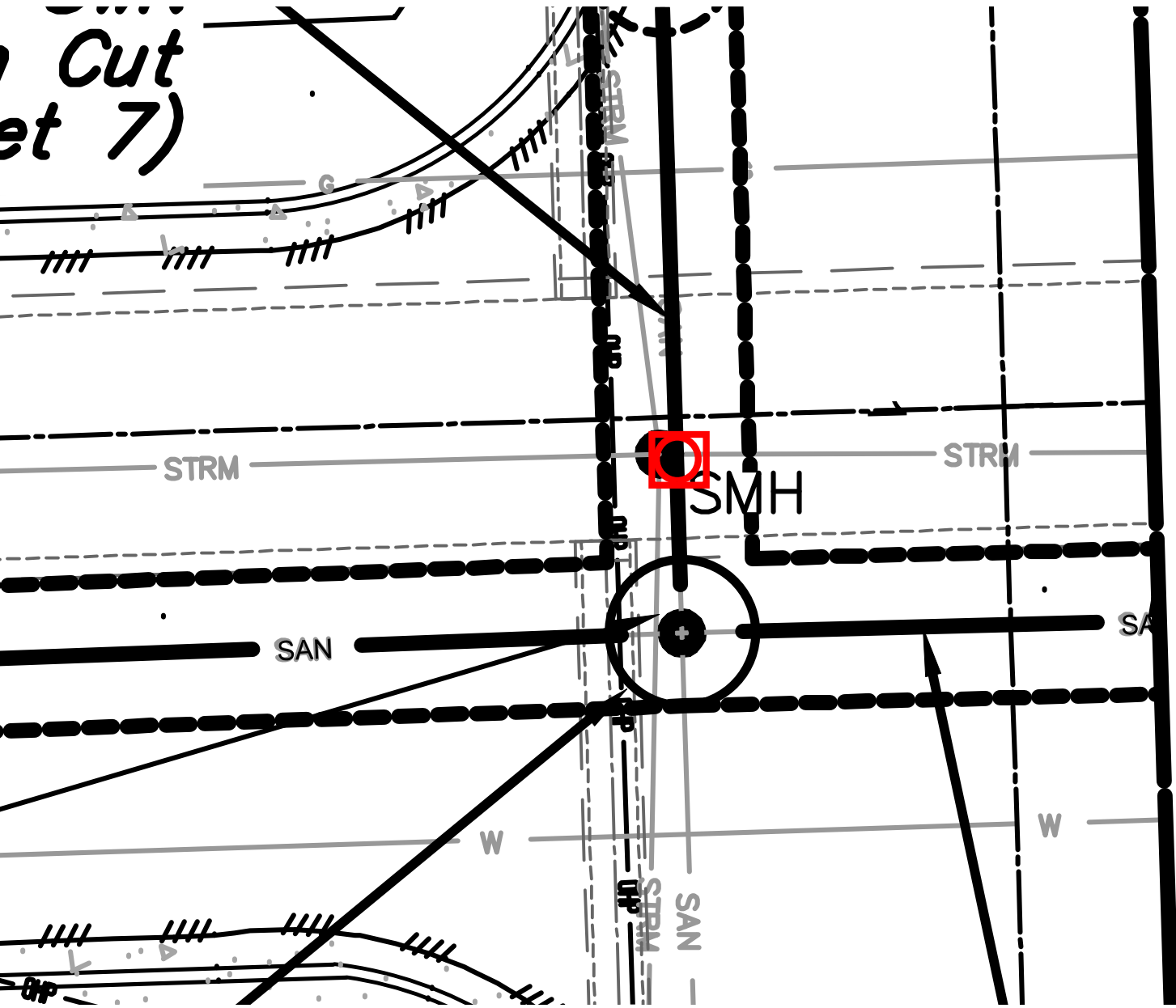

CH LINE ~ STA

5



W Grand Parkway North, Suite 150
Katy, Texas 77449
Tel: 832.913.4000
www.quiddity.com

CHANGE ORDER NO. 002

DATE: May 27, 2022

Project: Construction of Colorado River Flood Control Hughes Street Utility Relocation	JC Job No.: 05135-0224-00
Owner: City of Wharton	Contractor: Arranda Industries, LLC

Description of Changes: The Contractor is directed to furnish all materials, labor and equipment to remove and replace manhole on existing 54" storm line.

Reason for Changes: Due to conflict with storm manhole, the storm manhole needs to be removed and relocated.

<u>Change in Contract price and time summary:</u>	<u>COST</u>	<u>TIME</u>
Original Contract:	\$839,419.00	120 Calendar Days
Net previous change(s):	\$8,000.00	0 Calendar Days
Contract prior to this change order:	\$847,419.00	120 Calendar Days
Net increase from this change order:	\$15,946.00	0 Calendar Days
Revised Contract Amount:	\$863,365.00	120 Calendar Days
Cumulative % Change in Contract:	2.85 %	0.00 %
Project Completion Date:	February 23, 2022	

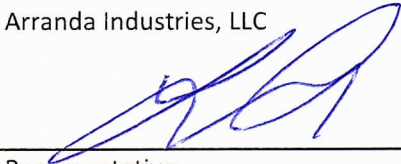
<p>APPROVED BY: City of Wharton</p> <p>_____</p> <p>Representative</p> <p>_____</p> <p>Date</p>	<p>RECOMMENDED BY: Jones & Carter, Inc.</p> <p style="text-align:center"></p> <p>_____</p> <p>Kristen Hennings, PE, CFM, LEED® Green Associate</p> <p style="text-align:right">6/1/2022</p> <p>_____</p> <p>Date</p> <p>ACCEPTED BY: Arranda Industries, LLC</p> <p style="text-align:center"></p> <p>_____</p> <p>Representative</p> <p style="text-align:right">6/1/22</p> <p>_____</p> <p>Date</p>
Enclosures: Attachment No. 001	

K:\05135\05135-0224-00 City of Wharton Colorado River Flood Con\3 Construction Phase\Change Orders\Hughes Street\CO2\05135-0224-00 Hughes CO 2

CONSTRUCTION OF COLORADO RIVER FLOOD CONTROL HUGHES STREET UTILITY RELOCATION

The Contractor is directed to furnish all materials, labor and equipment to remove and replace manhole on existing 54" storm line.

To implement payment for this work, the following revision is made to the Item/Quantity Sheets:

<u>Item No.</u>	<u>Description</u>	<u>Unit</u>	<u>Unit Price</u>	<u>Revised Unit Price</u>	<u>Bid Quantity</u>	<u>Revised Quantity</u>	<u>Previous Amount</u>	<u>Revised Amount</u>	<u>Net Change</u>
37	Manhole removal & replacement on existing 54" storm line	EA.	\$0.00	\$7,973.00	0	2	\$0.00	\$15,946.00	\$15,946.00
								NET INCREASE IN CONTRACT PRICE	\$15,946.00

There are zero (0) days added to the Contract Period of Performance.



CERTIFICATE OF INTERESTED PARTIES

FORM 1295

1 of 1

Complete Nos. 1 - 4 and 6 if there are interested parties.
Complete Nos. 1, 2, 3, 5, and 6 if there are no interested parties.

OFFICE USE ONLY CERTIFICATION OF FILING

Certificate Number:
2022-893299

Date Filed:
06/01/2022

Date Acknowledged:

1 Name of business entity filing form, and the city, state and country of the business entity's place of business.

ARANDA INDUSTRIES, LLC.
HOUSTON, TX United States

2 Name of governmental entity or state agency that is a party to the contract for which the form is being filed.

CITY OF WHARTON

3 Provide the identification number used by the governmental entity or state agency to track or identify the contract, and provide a description of the services, goods, or other property to be provided under the contract.

05135-0224-00
CONSTRUCTION OF COLORADO RIVER FLOOD CONTROL HUGHES STREET UTILITY RELOCATION - CHANGE ORDER NO. 2

4	Name of Interested Party	City, State, Country (place of business)	Nature of interest (check applicable)	
			Controlling	Intermediary

5 Check only if there is NO Interested Party.

6 UNSWORN DECLARATION

My name is Luis Aranda, and my date of birth is 04/04/1992.

My address is 4206 Northwind Ln, Houston, TX, 77014, USA.
(street) (city) (state) (zip code) (country)

I declare under penalty of perjury that the foregoing is true and correct.

Executed in Harris County, State of Texas, on the 01 day of JUNE, 2022.
(month) (year)

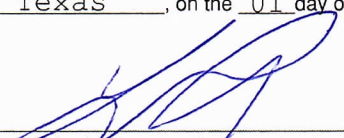

Signature of authorized agent of contracting business entity
(Declarant)

CHANGE ORDER 2

ARANDA INDUSTRIES LL
4206 NORTHWIND LANE
HOUSTON, TX 77014
TEL: 832-566-6769

Item-9.



ESTIMATE BY: LUIS ARANDA

QTY UNIT PRICE AMOUNT

CHANGE ORDER ITEMS

MANHOLE REMOVAL & REPLACEMENT ON EXISTING 54" STORM LINE	EA	2	7,973.00	15,946.00
				<hr/> 15,946.00

**CITY OF WHARTON
RESOLUTION NO. 2022-XX**

A RESOLUTION OF THE WHARTON CITY COUNCIL AUTHORIZING AND APPROVING CHANGE ORDER NO. 2 WITH ARANDAS INDUSTRIES FOR THE WHARTON COLORADO RIVER FLOOD CONTROL PUBLIC UTILITY ABANDONMENT – HUGHES STREET AND AUTHORIZING THE MAYOR TO EXECUTE ALL DOCUMENTS RELATED TO SAID CHANGE ORDER.

WHEREAS, The Wharton City Council wishes to authorize and approve Change Order No. 2 with Arandas Industries for the Wharton Colorado River Flood Control Public Utility Abandonment-Hughes Street; and,

WHEREAS, The Wharton City Council wishes to authorize the Mayor to execute all documents related to the change order.

NOW, THEREFORE, BE IT RESOLVED BY THE CITY COUNCIL OF THE CITY OF WHARTON, TEXAS as follows:

Section I. The Wharton City Council hereby approves Change Order No. 2 with Arandas Industries for the Wharton Colorado River Flood Control Public Utility Abandonment-Hughes Street.

Section II. The Wharton City Council hereby authorizes the Mayor to execute all documents related to the change order.

Section III. That this resolution shall become effective immediately upon its passage.

Passed, Approved, and Adopted this 27th day of June 2022.

CITY OF WHARTON, TEXAS

By: _____
TIM BARKER
Mayor

ATTEST:

PAULA FAVORS
City Secretary

City of Wharton
 120 E. Caney Street
 Wharton, TX 77488

CITY COUNCIL COMMUNICATION

Meeting Date:	6/27/2022	Agenda Item:	Resolution: A resolution of the Wharton City Council authorizing and approving Change Order No. 3 with Arandas Industries for the Wharton Colorado River Flood Control Public Utility Abandonment – Hughes Street and authorizing the Mayor to execute all documents related to said Change Order.
<p>Attached is the Wharton Colorado River Flood Control Public Utility Abandonment-Hughes Street - Change Order #3 from Arandas Industries for the modification of repairs on an area that was originally designed for a 6" waterline. Once construction crews were on location and began repairs it was discovered the existing lines were 8" lines and the change order are for the substitution of those items to the original scope.</p> <p>Attached is a copy of the change order for review.</p> <p>Director of Planning & Development, Gwyn Teves, will be present to answer any questions.</p>			
City Manager: Joseph R. Pace		Date: Thursday, June 23, 2022	
Approval: 			
Mayor: Tim Barker			



City of Wharton

120 E. Caney • Wharton, TX 77488
Phone (979) 532-2491 • Fax (979) 532-0181

MEMORANDUM

DATE: June 21, 2022

FROM: Gwyneth Teves, Director of Planning & Development

TO: Honorable Mayor and City Councilmembers, City Manager Joseph R. Pace, and City Attorney Paul Webb

SUBJECT: Wharton Colorado River Flood Control Public Utility Abandonment – Hughes St. - Change Order #3

Attached please find the Wharton Colorado River Flood Control Public Utility Abandonment-Hughes St - Change Order #3 from Arandas Industries for the modification of repairs on an area that was originally designed for a 6” waterline. Once construction crews were on location and began repairs it was discovered the existing lines were 8” lines and the change order are for the substitution of those items to the original scope. Attached is a copy of the change order for review.

It is the recommendation of the engineering consultant and City staff that the Council approve the change order for the difference in cost of \$3,984.00.

If you should have any questions, please contact me at 979-532-2491. Thank You.

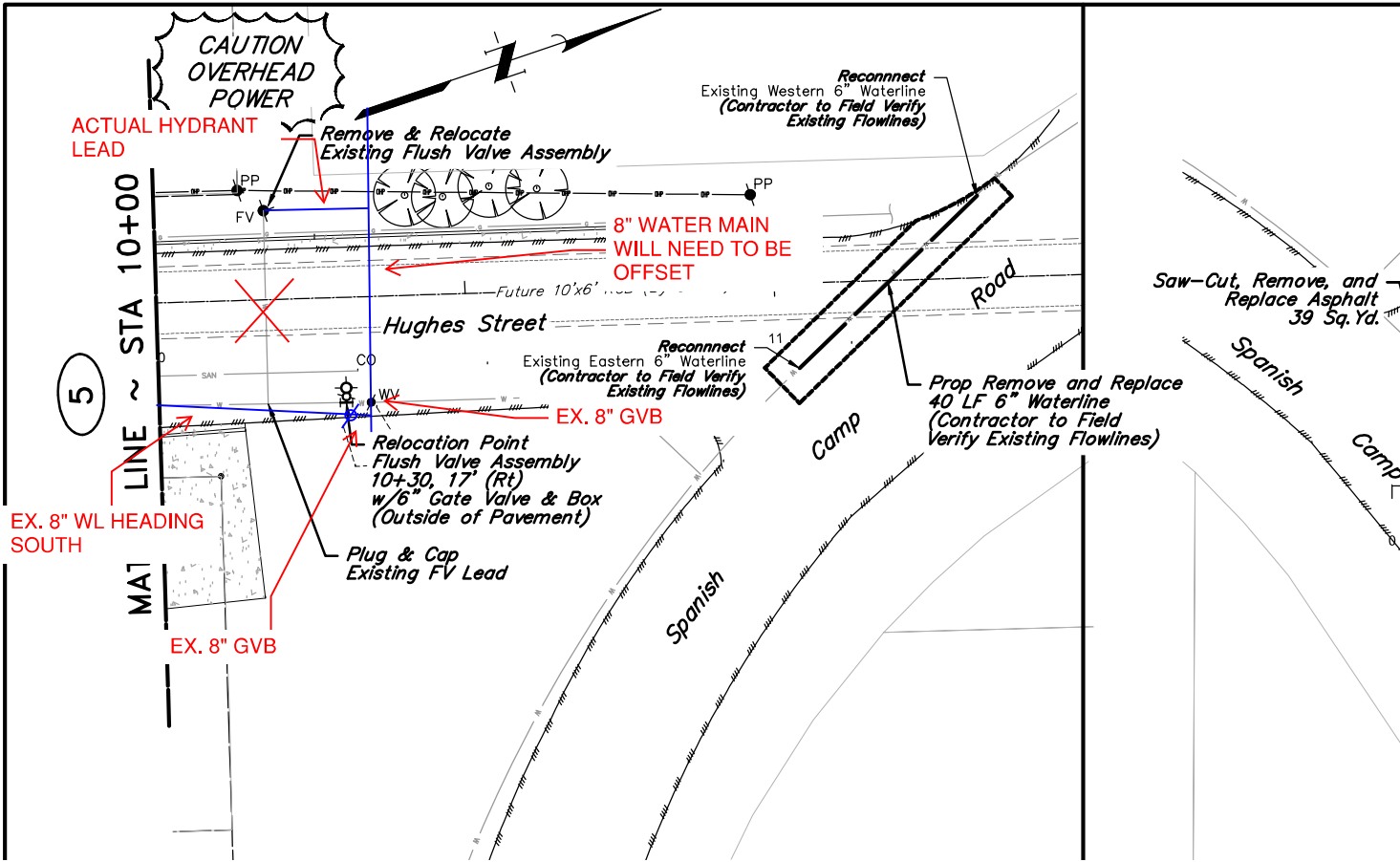

CHANGE ORDER 3

ARANDA INDUSTRIES L
 4206 NORTHWIND LANE
 HOUSTON, TX 77014
 TEL: 832-566-6769

Item-10.



ESTIMATE BY: LUIS ARANDA

QTY UNIT PRICE AMOUNT

CHANGE ORDER ITEMS FOR 8" WATERLINE

1	REMOVE EXIST 8-INCH PVC WATERLINE	LF	80	268.00	21,440.00
2	8-INCH C-900 AWWA (DR18) CLASS 150, WATERLINE	LF	80	268.00	21,440.00
3	8-INCH X 45° RESTRAINED JOINT BENDS	EA	8	944.00	7,552.00
					50,432.00

DEDUCTIVE CHANGE ORDER ITEMS FOR 6" WATERLINE

1	REMOVE EXIST 6-INCH PVC WATERLINE	LF	80	(249.00)	(19,920.00)
2	6-INCH C-900 AWWA (DR18) CLASS 150, WATERLINE	LF	80	(249.00)	(19,920.00)
3	6-INCH X 45° RESTRAINED JOINT BENDS	EA	8	(826.00)	(6,608.00)
					(46,448.00)

TOTAL ADDITIONAL FUNDS	3,984.00
------------------------------	----------

**CITY OF WHARTON
RESOLUTION NO. 2022-XX**

A RESOLUTION OF THE WHARTON CITY COUNCIL AUTHORIZING AND APPROVING CHANGE ORDER NO. 3 WITH ARANDAS INDUSTRIES FOR THE WHARTON COLORADO RIVER FLOOD CONTROL PUBLIC UTILITY ABANDONMENT – HUGHES ST AND AUTHORIZING THE MAYOR TO EXECUTE ALL DOCUMENTS RELATED TO SAID CHANGE ORDER.

WHEREAS, The Wharton City Council wishes to authorize and approve Change Order No. 3 with Arandas Industries for the Wharton Colorado River Flood Control Public Utility Abandonment-Hughes St.; and,

WHEREAS, The Wharton City Council wishes to authorize the Mayor to execute all documents related to the change order.

NOW, THEREFORE, BE IT RESOLVED BY THE CITY COUNCIL OF THE CITY OF WHARTON, TEXAS as follows:

Section I. The Wharton City Council hereby approves Change Order No. 3 with Arandas Industries for the Wharton Colorado River Flood Control Public Utility Abandonment-Hughes St.

Section II. The Wharton City Council hereby authorizes the Mayor to execute all documents related to the change order.

Section III. That this resolution shall become effective immediately upon its passage.

Passed, Approved, and Adopted this 27th day of June 2022.

CITY OF WHARTON, TEXAS

By: _____
TIM BARKER
Mayor

ATTEST:

PAULA FAVORS
City Secretary

City of Wharton
 120 E. Caney Street
 Wharton, TX 77488

CITY COUNCIL COMMUNICATION

Meeting Date:	6/27/2022	Agenda Item:	Resolution: A resolution of the Wharton City Council approving Change Order No. 5 due to cost increases due to roof fan model changes with E Contractors for the Wharton Well and Water Plant Project and authorizing the Mayor to execute all documents related to said change order.
<p>Attached is the Wharton Well & Water Plant – Contract #1 (General Construction), Change Order #5 from E-Contractors to increase costs for Contract #1 for the new water well in the amount of \$1,605.98 due to roof fan model change.</p> <p>Attached is a copy of the change order for review.</p> <p>Director of Planning & Development, Gwyn Teves, will be present to answer any questions.</p>			
City Manager: Joseph R. Pace		Date: Thursday, June 23, 2022	
Approval: 			
Mayor: Tim Barker			



City of Wharton

120 E. Caney • Wharton, TX 77488
Phone (979) 532-2491 • Fax (979) 532-0181

MEMORANDUM

DATE: June 21, 2022

FROM: Gwyneth Teves, Director of Planning & Development

TO: Honorable Mayor and City Councilmembers, City Manager Joseph R. Pace, and City Attorney Paul Webb

SUBJECT: Wharton Well & Water Plant – Contract # 1 (General Construction), Change Order #5

Attached please find the Wharton Well & Water Plant – Contract #1 (General Construction), Change Order #5 from E-Contractors to increase costs for Contract #1 for the new water well \$1,605.98 due to roof fan model change. Attached is a copy of the change order for review.

If you should have any questions, please contact me at 979-532-2491. Thank You.

Date of Issuance: April 04, 2022
 Owner: City of Wharton
 Contractor: E Contractors
 Engineer: Halff Associates, Inc.
 Project: Wharton Well and Water Plant

Effective Date:
 Owner's Contract No.: CFDA # 10.760
 Contractor's Project No.: 20-0200
 Engineer's Project No.: AVO31934
 Contract Name: COW-
 Wharton Well & Water
 Plant

The Contract is modified as follows upon execution of this Change Order: Increase the total amount by \$1,605.98

Description: Since the contract had been awarded, On December 09, 2021 sheet M-002 revised the type of roof fan model GB-260 to model GB-330. The items of work covered by these increases: 23-0500. HVAC. Other

Attachments: *PCO#005* Cost proposals and documents to support the price increase.

CHANGE IN CONTRACT PRICE	CHANGE IN CONTRACT TIMES <i>[note changes in Milestones if applicable]</i>
Original Contract Price: \$ <u>2,600,000.00</u>	Original Contract Times: Substantial Completion: <u>April 27, 2022</u> Ready for Final Payment: _____ days or dates
[Increase] [Decrease] from previously approved Change Orders No. <u>01</u> to No. <u>05</u> : \$ <u>182,124.17</u>	[Increase] [Decrease] from previously approved Change Orders No. ___ to No. ___: Substantial Completion: <u>0 days</u> Ready for Final Payment: <u>0days</u> days
Contract Price prior to this Change Order: \$ <u>2,715,484.87</u>	Contract Times prior to this Change Order: Substantial Completion: <u>270 days</u> Ready for Final Payment: <u>300 days</u> days or dates
[Increase] [Decrease] of this Change Order: \$ <u>1,605.98</u>	[Increase] [Decrease] of this Change Order: Substantial Completion: <u>0 days</u> Ready for Final Payment: <u>0 days</u> days or dates
Contract Price incorporating this Change Order: \$ <u>2,717,090.85</u>	Contract Times with all approved Change Orders: Substantial Completion: <u>270 days</u> Ready for Final Payment: <u>300 days</u> days or dates

RECOMMENDED:		ACCEPTED:		ACCEPTED:	
By: <u>Vincent M. Pina, P.E.</u>	By: _____	By: <u>Chris Jay</u>	_____		
Engineer (if required)	Owner (Authorized Signature)	Contractor (Authorized Signature)			
Title: <u>Construction Manager</u>	Title _____	Title <u>Operations Mgr.</u>	_____		
Date: <u>06/20/2022</u>	Date _____	Date <u>06/17/2022</u>	_____		

Approved by Funding Agency (if applicable)

By: _____ Date: _____
Title: _____

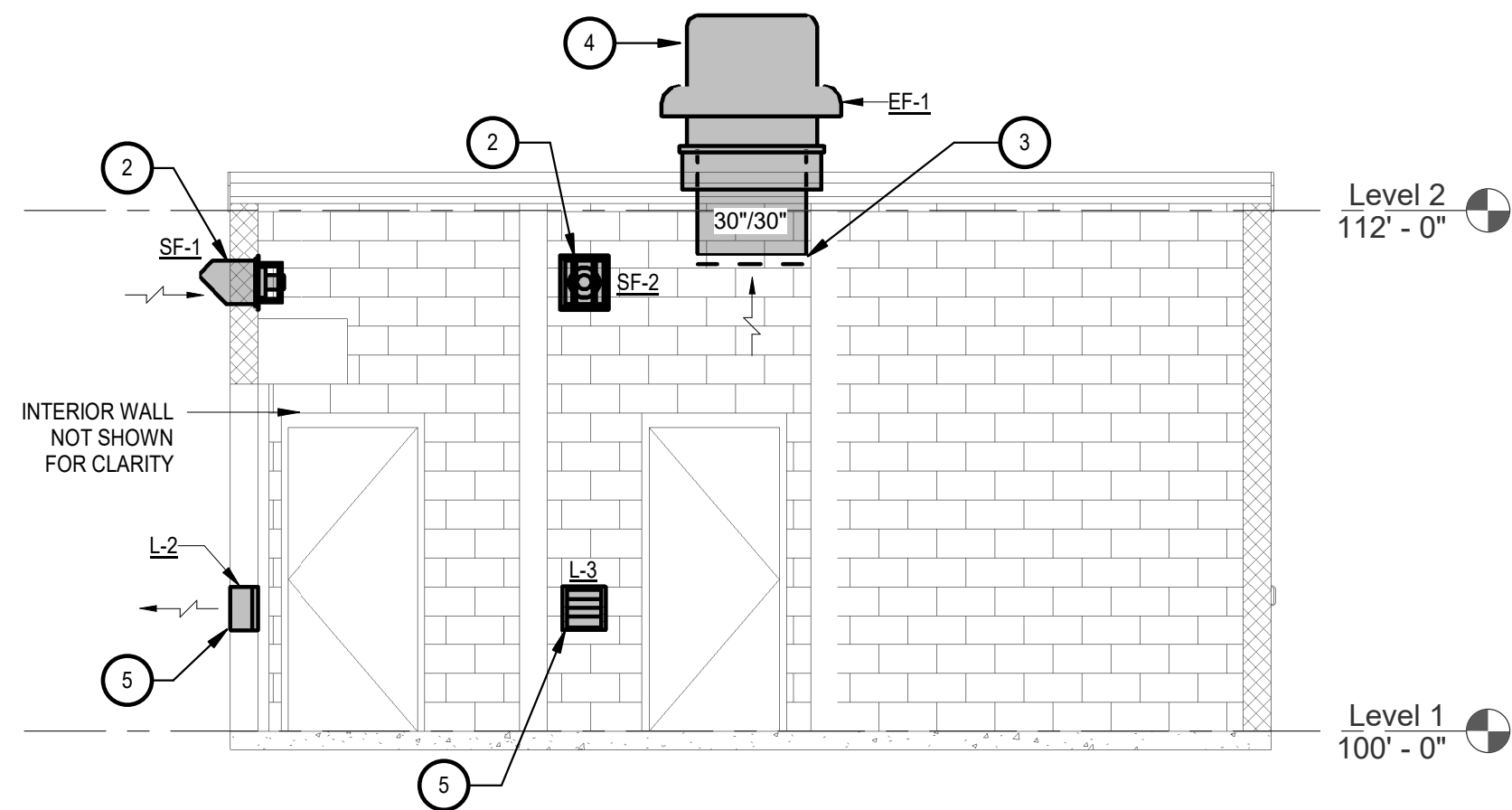

2 MECHANICAL HVAC SECTION
1/4" = 1'-0"

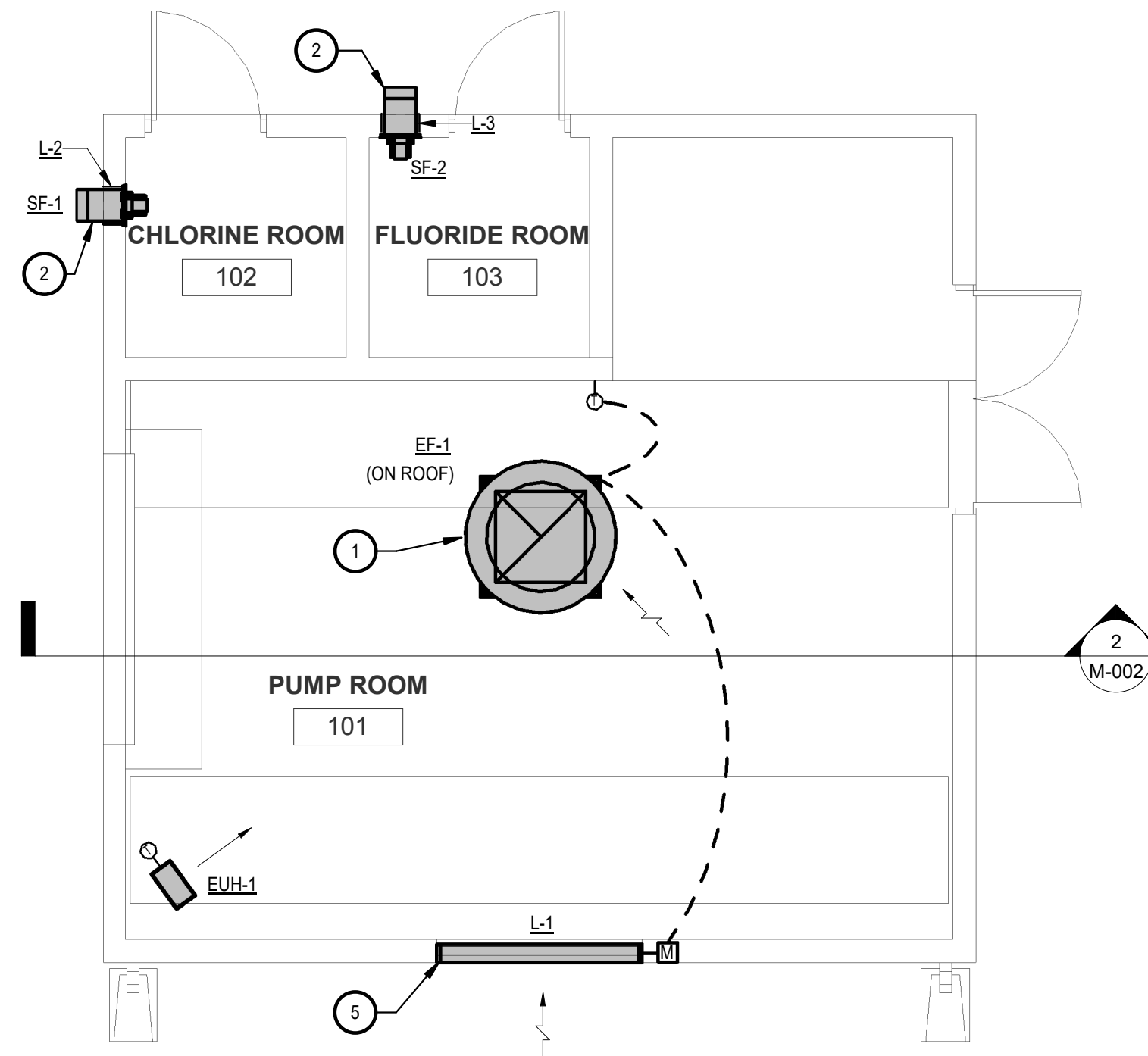

1 MECHANICAL HVAC PLAN - 1ST FLR
1/4" = 1'-0"

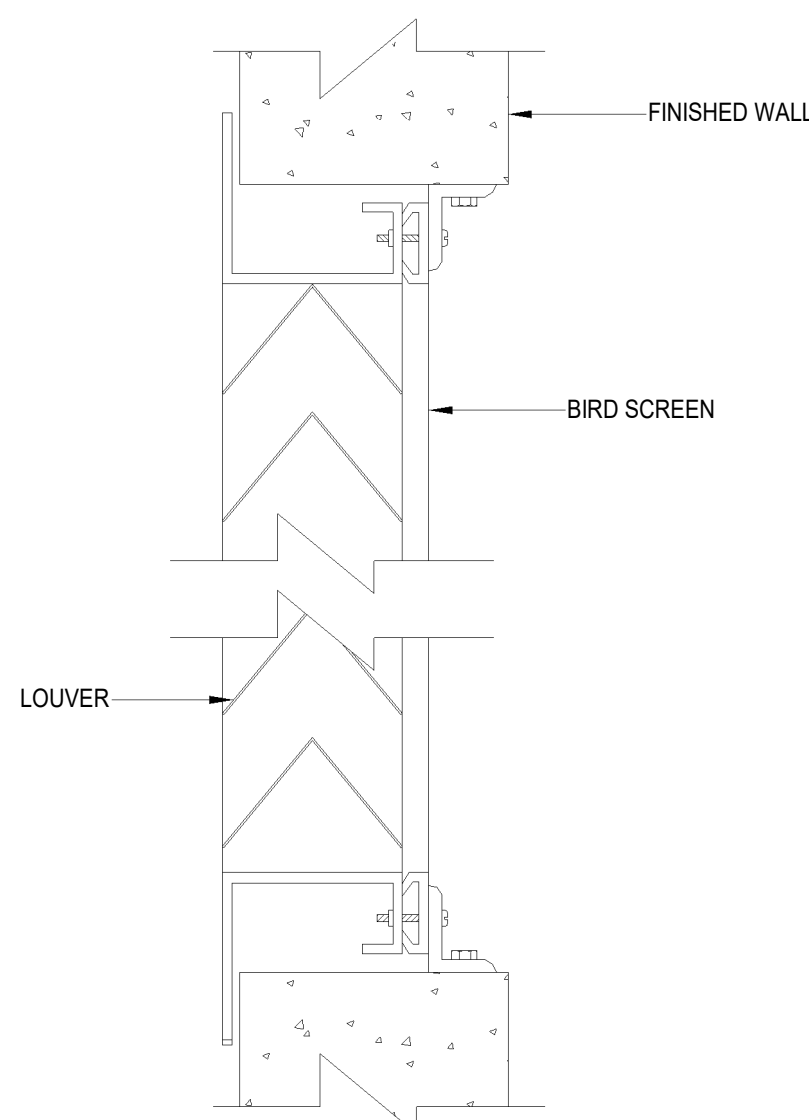

4 WALL LOUVER
N.T.S.

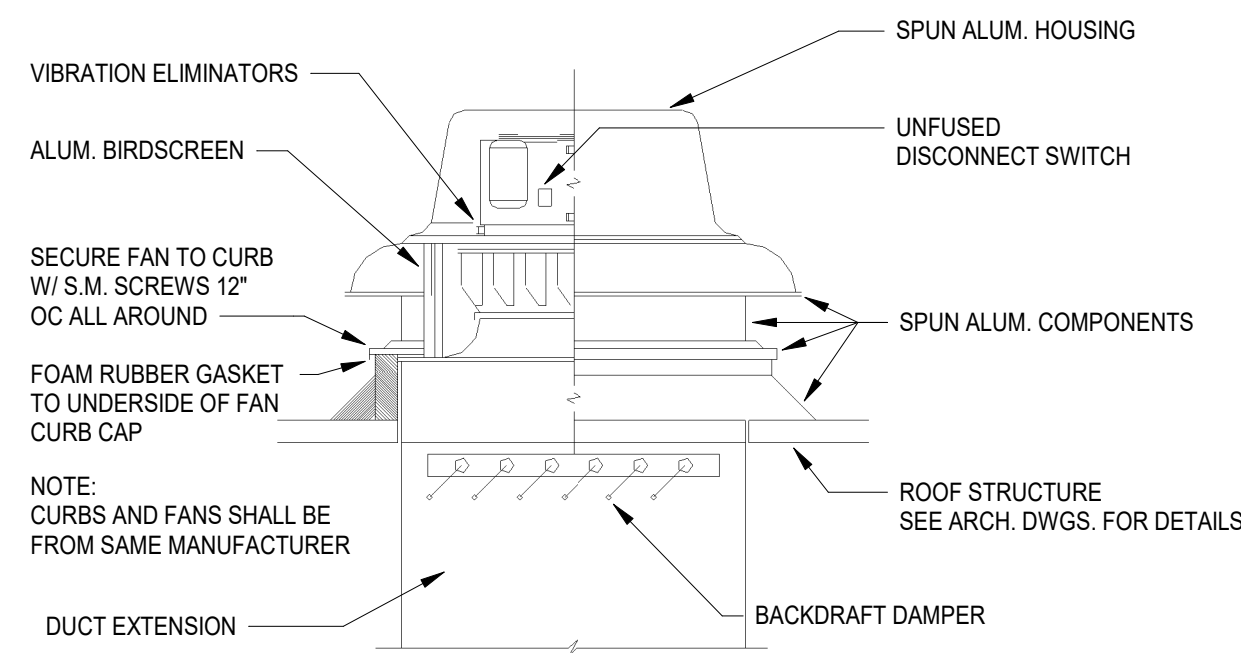

3 ROOF MOUNTED CENTRIFUGAL EXHAUST FAN - DOWNBLAST
N.T.S.

FAN SCHEDULE															
MARK	SERVES	LOCATION	MANUFACTURER	MODEL	AIR FLOW	ESP	HP	BHP	RPM	DRIVE	VOLTAGE	PHASE	SONES	WEIGHT	NOTES
EF-1	PUMP ROOM	ROOF	GREENHECK	GB-330	8700 CFM	0.50 in-wg	2 hp	1.64 hp	465	BELT	230 V	1	12.9	200 lb	4, 5
SF-1	CHLORINE ROOM	WALL	GREENHECK	SS1-8-440-D	150 CFM	0.25 in-wg	0.13 hp	0.03 hp	1500	DIRECT	120 V	1	5.4	20 lb	1, 2, 3
SF-2	FLORIDE ROOM	WALL	GREENHECK	SS1-8-440-D	150 CFM	0.25 in-wg	0.13 hp	0.03 hp	1550	DIRECT	120 V	1	5.4	20 lb	1, 2, 3

- NOTES:
 1. PROVIDE WITH MANUFACTURE FINISHED 90 DEGREE TURN DOWN INTAKE WEATHER HOOD AND INSECT SCREEN.
 2. PROVIDE WITH MOTOR SIDE WIRE GUARD.
 3. PROVIDE PHINOLIC EPOXY POWDER COATING (KYNAR) ON ENTIRE ASSEMBLY AND ALL ACCESSORIES.
 4. PROVIDE FAN WITH LINE VOLTAGE THERMOSTAT AND INTERLOCK TO ONLY RUN WHEN LOUVER L-1 DAMPER HAS OPENED.
 5. PROVIDE FAN WITH FACTORY FURNISHED INSULATED ROOF CURB.

ELECTRIC UNIT HEATER									
DESIGNATION	LOCATION	FAN			HEATING OUTPUT	ELECTRICAL	MANUFACTURER	MODEL	NOTES
		CFM	RPM	HP					
EUH-1	PUMP ROOM	350 CFM	1600	1/100	3 kW	240V / 1PH	QMARK	MUH0321	1, 2

- NOTES:
 1. PROVIDE WITH MANUFACTURER FURNISHED WALL MOUNTING BRACKET.
 2. PROVIDE WITH UNIT MOUNTED THERMOSTAT CONTROLS. THERMOSTAT SETPOINT SHALL BE SET TO 50 DEG. F. FOR FREEZE PROTECTION. REFER TO IECC 2015 C402.1.2.

LOUVER SCHEDULE													
MARK	LOCATION	SYSTEM AND/OR SERVICE	TYPE	APPLICATION	HEIGHT	WIDTH	FREE AREA	NOMINAL AIRFLOW	MAX VELOCITY	MAX APD	MANUFACTURER	MODEL	NOTES
L-1	SOUTH WALL	EF-1	COMBINATION	INTAKE AIR	4'-8"	5'-8"	11.27 ft²	8700 CFM	785 FPM	0.08 in-wg	RUSKIN	ELC445D	1, 2
L-2,3	NORTH WALL	EF-2,3	FIXED	RELIEF AIR	1'-0"	1'-0"	0.38 ft²	150 CFM	350 FPM	0.08 in-wg	RUSKIN	ELF30V	1, 3

- NOTES:
 1. PROVIDE WITH GALVANIZED SCREEN WITH 3/4" SPACING.
 2. PROVIDE WITH 120V ACTUATOR WITH SPRING RETURN (FAIL CLOSED) AND END SWITCH FOR INTERLOCK TO EF-1.
 3. PROVIDE PHINOLIC EPOXY POWDER COATING (KYNAR) ON ENTIRE ASSEMBLY. COLOR TO BE SELECTED BY ARCHITECT.

GENERAL NOTES:

- A. REFER TO SHEET M1 FOR GENERAL MECHANICAL NOTES.

KEY NOTES:

- PROVIDE THERMOSTATIC CONTROL FOR EF-1. INTERLOCK EF-1 FAN STARTER WITH MOTORIZED DAMPER ON INTAKE LOUVER L-1. ON A TEMPERATURE RISE ABOVE 80 DEG. F (ADJ.) OPEN THE LOUVER AND ENABLE THE FAN. DISABLE THE FAN AND CLOSE THE LOUVER ON A FALL BELOW 75 DEG. F (ADJ.).
- WALL MOUNTED FANS SF-1 AND SF-2 SHALL BE CONFIGURED TO BLOW IN AND PRESSURIZE THEIR RESPECTIVE ROOMS. AIR SHALL BE RELIEVED THROUGH THE LOW WALL LOUVER. PROVIDE FAN WITH MANUFACTURER FURNISHED 90 DEGREE INTAKE WEATHER HOOD. FANS SHALL OPERATE AT ALL TIMES UNDER NORMAL CONDITIONS AND BE SWITCHABLE THROUGH A DEDICATED ELECTRICAL BREAKER FOR EACH FAN IN THE ELECTRICAL PANEL. PROVIDE FAN RUN STATUS INDICATION PILOT LIGHT (WEATHER PROOF) AT EXTERIOR OF ENTRY DOOR.
- TERMINATE EXHAUST DUCTWORK 12" BELOW ROOF DECK AND COVER OPENING WITH 1/2"x1/2" GALVANIZED STEEL SCREEN MESH.
- LOCATE EXHAUST FAN EF-1 NEAR CENTER OF ROOF WITH MINIMUM 10 FOOT CLEARANCE TO ROOF EDGE ON ALL SIDES.
- REFER TO ARCHITECTURAL DRAWINGS FOR EXACT LOUVER MOUNTING HEIGHT AND LOCATION.

WHARTON WELL AND WATER PLANT
 CONTRACT NO. 1
 CFDA NO. 10.760
 WHARTON, TEXAS



HALFF
 1201 NORTH BOWSER ROAD
 RICHARDSON, TEXAS 75081-2275
 TEL: 972-348-6330
 TBE FIRM #F-312

Revision No.	Date	Description
1	12/09/2021	REVISION 1



THE SEAL APPEARING ON THIS DOCUMENT WAS AUTHORIZED BY CLINTON BELL, PE NO. 99400 ON 12/09/2021. ALTERATION OF A SEALED DOCUMENT WITHOUT PROPER NOTIFICATION TO THE RESPONSIBLE ENGINEER IS AN OFFENSE UNDER THE TEXAS ENGINEERING PRACTICE ACT. THE RECORD COPY OF THIS DRAWING IS ON FILE AT THE OFFICES OF HALFF ASSOCIATES, INC. 1201 NORTH BOWSER ROAD, RICHARDSON, TX 75081-2275. TBE FIRM #F-312

Project No.:	31934
Issued:	06/25/2020
Drawn By:	JG
Checked By:	BB
Scale:	As indicated

MECHANICAL PLAN

M-002
 Sheet Number

**CITY OF WHARTON
RESOLUTION NO. 2022-XX**

A RESOLUTION OF THE WHARTON CITY COUNCIL APPROVING CHANGE ORDER NO. 5 DUE TO COST INCREASES DUE TO ROOF FAN MODEL CHANGE WITH E CONTRACTORS FOR THE WHARTON WELL AND WATER PLANT PROJECT AND AUTHORIZING THE MAYOR TO EXECUTE ALL DOCUMENTS RELATED TO SAID CHANGE ORDER.

WHEREAS, The Wharton City Council wishes to approve Change Order No. 5 due to cost increases due to roof fan model change with E Contractors for the Wharton Well and Water Plant Project; and,

WHEREAS, The Wharton City Council wishes to authorize the Mayor to execute all documents related to the change order.

NOW, THEREFORE, BE IT RESOLVED BY THE CITY COUNCIL OF THE CITY OF WHARTON, TEXAS as follows:

Section I. The Wharton City Council hereby authorizes Change Order No. 5 due to cost increases due to roof fan model change with E Contractors for the Wharton Well and Water Plant Project.

Section II. The Wharton City Council hereby authorizes the Mayor to execute all documents related to the change order.

Section III. That this resolution shall become effective immediately upon its passage.

Passed, Approved, and Adopted this 27th day of June 2022.

CITY OF WHARTON, TEXAS

By: _____
TIM BARKER
Mayor

ATTEST:

PAULA FAVORS
City Secretary

City of Wharton
 120 E. Caney Street
 Wharton, TX 77488

CITY COUNCIL COMMUNICATION

Meeting Date:	6/27/2022	Agenda Item:	Pay Request No. 5 from E-Contractors for the Wharton Well and Water Plant Contract No. 1 – General Construction.
<p>Attached you will find Pay Request No. 5 from E-Contractors for the Wharton Well and Water Plant Contract No. 1 – General Construction in the amount of \$144,433.50.</p> <p>Director of Planning & Development, Gwyn Teves, will be present to answer any questions.</p>			
City Manager: Joseph R. Pace		Date: Thursday, June 23, 2022	
Approval: 			
Mayor: Tim Barker			



City of Wharton

120 E. Caney • Wharton, TX 77488
Phone (979) 532-2491 • Fax (979) 532-0181

MEMORANDUM

DATE: June 22, 2022

FROM: Gwyneth Teves, Director of Planning & Development

TO: Honorable Mayor and City Council

SUBJECT: Recommendation for payment to E-Contractors for the Wharton Well and Water Plant Contract No. 1 – General Construction Pay Estimate No. 5 – January and February 2022

The City Council awarded a contract for construction to E-Contractors for the Wharton Well and Water Plant Contract No. 1 – General Construction.

Pay Estimate No. 5 has been sent and recommendation for payment by the engineer are attached.

It is my recommendation that the City Council approve the invoice in the amount of \$144,433.50 and recommend payment.

If you should have any questions, please contact me at 979-532-2491 ext. 238. Thank You.



June 20, 2022
AVO31934.001

Mr. Anthony Arcidiacono
City of Wharton
120 E. Caney Street
Wharton, TX, 77488

**RE: Wharton Well and Water Plant
Contract No. 1 – General Construction
Pay Estimate No. 5 – Price Increase Change Orders**

Dear Mr. Arcidiacono,

E-Contractors has submitted the following pay estimate for the above-referenced project:

Pay Estimate No.: 5
Dated: 3/9/2022
For Work Period: Price Increases
Balance Due: \$144,433.50

Halff Associates reviewed the estimate and recommend it for payment.

Please call me at 832-600-8663 if you have any questions or comments.

Sincerely,
HALFF ASSOCIATES, INC.

A handwritten signature in blue ink that reads "Vincent M. Peña, PE".

Vincent M. Peña, PE
Construction Manager

cc: Gwyneth Teves, City of Wharton
Amy Horelica, City of Wharton
Megan Morris, USDA
Eric Caudill, City Inspector
Tim Lackey, Halff Project Manager



Contractor's Application for Payment No.

5

Application Period: 03/01/2021 - 05/20/2022		Application Date: 5/31/2022
To (Owner): City of Wharton	From (Contractor): E Contractor USA, LLC	Via (Engineer): Haliff Associates, Inc.
Project: Wharton Well and Water Plant	Contract: Contract 1	
Owner's Contract No.: CFDA No. 10.760	Contractor's Project No.: 20-0200	Engineer's Project No.: 31934

Application For Payment

Change Order Summary

Approved Change Orders		
Number	Additions	Deductions
CO #1	\$23,424.98	
CO #2	\$92,059.89	
CO #3	\$66,639.30	
TOTALS		
	\$182,124.17	
NET CHANGE BY CHANGE ORDERS		
	\$182,124.17	

1. ORIGINAL CONTRACT PRICE.....	\$ 2,600,000.00
2. Net change by Change Orders.....	\$ 182,124.17
3. Current Contract Price (Line 1 ± 2).....	\$ 2,782,124.17
4. TOTAL COMPLETED AND STORED TO DATE (Column F total on Progress Estimates).....	\$ 1,798,817.85
5. RETAINAGE:	
a. X 5% Work Completed.....	\$ 89,940.92
b. X 5% Stored Material.....	\$
c. Total Retainage (Line 5.a + Line 5.b).....	\$ 89,940.92
6. AMOUNT ELIGIBLE TO DATE (Line 4 - Line 5.c).....	\$ 1,708,876.93
7. LESS PREVIOUS PAYMENTS (Line 6 from prior Application).....	\$ 1,564,443.43
8. AMOUNT DUE THIS APPLICATION.....	\$ 144,433.50
9. BALANCE TO FINISH, PLUS RETAINAGE (Column G total on Progress Estimates + Line 5.c above).....	\$ 1,073,247.24

Contractor's Certification

The undersigned Contractor certifies, to the best of its knowledge, the following:
 (1) All previous progress payments received from Owner on account of Work done under the Contract have been applied on account to discharge Contractor's legitimate obligations incurred in connection with the Work covered by prior Applications for Payment;
 (2) Title to all Work, materials and equipment incorporated in said Work, or otherwise listed in or covered by this Application for Payment, will pass to Owner at time of payment free and clear of all Liens, security interests, and encumbrances (except such as are covered by a bond acceptable to Owner indemnifying Owner against any such Liens, security interest, or encumbrances); and
 (3) All the Work covered by this Application for Payment is in accordance with the Contract Documents and is not defective.

Contractor Signature

By: Managing Member Date: 6/22/2022

Payment of: \$ 144,433.50
 (Line 8 or other - attach explanation of the other amount)

is recommended by: Vincent M. Pena, PE 06/22/2022
 (Engineer) (Date)

Payment of: \$ _____
 (Line 8 or other - attach explanation of the other amount)

is approved by: _____ (Date)

Approved by: _____ (Date)
 Funding or Financing Entity (if applicable)

Document SUMMARY SHEET, APPLICATION AND CERTIFICATE FOR PAYMENT, containing Contractor's signed Certification is attached.
 Note: Column I on Contracts where variable retainage for line items apply.

APPLICATION NUMBER: 5

APPLICATION DATE:

PERIOD: 03/01/22 - 05/31/22

ARCHITECTS/ENGINEERS PROJECT NO:

GENERAL CONTRACTORS PROJECT NAME: COW-Wharton Well & Water Plant

GENERAL CONTRACTORS PROJECT NO: 20-0200

Item-12.

Contract Lines

A	B	C	D	E	F	G	H	I											
									TEM NO.	COST CODE	DESCRIPTION OF WORK	SCHEDULED VALUE	WORK COMPLETED		MATERIALS PRESENTLY STORED (NOT IN D OR E)	TOTAL COMPLETED AND STORED TO DATE (D+E+F)	% (G / C)	BALANCE TO FINISH (C - G)	RETAINAGE
													FROM PREVIOUS APPLICATION (D + E)	THIS PERIOD					
1	1-0010 - Bond	Bond	\$ 41,073.00	\$ 41,073.00	\$ 0.00	\$ 0.00	\$ 41,073.00	100.00%	\$ 0.00	\$ 2,053.65									
2	1-0020 - Insurance	Insurance	\$ 8,020.00	\$ 5,132.80	\$ 0.00	\$ 0.00	\$ 5,132.80	64.00%	\$ 2,887.20	\$ 256.64									
3	1-1010 - Site Supplies	Site Supplies	\$ 639.00	\$ 408.96	\$ 0.00	\$ 0.00	\$ 408.96	64.00%	\$ 230.04	\$ 20.45									
4	1-3000 - Project Administration	Project Administration	\$ 11,439.00	\$ 7,320.96	\$ 0.00	\$ 0.00	\$ 7,320.96	64.00%	\$ 4,118.04	\$ 366.05									
5	1-3100 - Project Manager	Project Manager	\$ 26,555.00	\$ 16,995.20	\$ 0.00	\$ 0.00	\$ 16,995.20	64.00%	\$ 9,559.80	\$ 849.76									
6	1-3120 - Jobsite Supervision	Jobsite Supervision	\$ 62,404.00	\$ 39,938.56	\$ 0.00	\$ 0.00	\$ 39,938.56	64.00%	\$ 22,465.44	\$ 1,996.93									
7	1-3510 - Safety Requirements	Safety Requirements	\$ 1,149.00	\$ 735.36	\$ 0.00	\$ 0.00	\$ 735.36	64.00%	\$ 413.64	\$ 36.77									
8	1-4120 - Permits & Fees	Permits & Fees	\$ 9,024.00	\$ 0.00	\$ 0.00	\$ 0.00	\$ 0.00	0.00%	\$ 9,024.00	\$ 0.00									
9	1-5000 - Temp Facilities & Controls	Temp Facilities & Controls	\$ 3,064.00	\$ 1,960.96	\$ 0.00	\$ 0.00	\$ 1,960.96	64.00%	\$ 1,103.04	\$ 98.05									
10	1-5110 - Temp Light & Power	Temp Light & Power	\$ 8,158.00	\$ 5,221.12	\$ 0.00	\$ 0.00	\$ 5,221.12	64.00%	\$ 2,936.88	\$ 261.06									
11	1-5210 - Field Offices & Sheds	Field Offices & Sheds	\$ 10,341.00	\$ 6,618.24	\$ 0.00	\$ 0.00	\$ 6,618.24	64.00%	\$ 3,722.76	\$ 330.91									
12	1-5723 - Storm Water Prevention Plan	Storm Water Prevention Plan	\$ 6,382.00	\$ 5,744.00	\$ 0.00	\$ 0.00	\$ 5,744.00	90.00%	\$ 638.00	\$ 287.20									
13	1-5800 - Project Signage	Project Signage	\$ 1,705.00	\$ 1,705.00	\$ 0.00	\$ 0.00	\$ 1,705.00	100.00%	\$ 0.00	\$ 85.25									
14	1-7420 - Final Cleaning	Final Cleaning	\$ 3,529.00	\$ 0.00	\$ 0.00	\$ 0.00	\$ 0.00	0.00%	\$ 3,529.00	\$ 0.00									
15	1-7820 - As-Builts / O&M Data	As-Builts / O&M Data	\$ 958.00	\$ 0.00	\$ 0.00	\$ 0.00	\$ 0.00	0.00%	\$ 958.00	\$ 0.00									
16	2-2100 - Survey	Survey	\$ 3,830.00	\$ 3,830.00	\$ 0.00	\$ 0.00	\$ 3,830.00	100.00%	\$ 0.00	\$ 191.50									
17	2-4119 - Dumpsters	Dumpsters	\$ 6,384.00	\$ 4,085.76	\$ 0.00	\$ 0.00	\$ 4,085.76	64.00%	\$ 2,298.24	\$ 204.29									
18	3-0500 - Concrete	Concrete Mobilization	\$ 2,833.00	\$ 2,833.00	\$ 0.00	\$ 0.00	\$ 2,833.00	100.00%	\$ 0.00	\$ 141.65									
19	3-0500 - Concrete	Concrete Pipe Bollards	\$ 804.00	\$ 0.00	\$ 0.00	\$ 0.00	\$ 0.00	0.00%	\$ 804.00	\$ 0.00									
20	3-0500 - Concrete	Concrete 539 SF 4.5" Sidewalk	\$ 8,618.00	\$ 0.00	\$ 0.00	\$ 0.00	\$ 0.00	0.00%	\$ 8,618.00	\$ 0.00									
21	3-0500 - Concrete	Concrete 24 SF ATS Pad	\$ 5,593.00	\$ 0.00	\$ 0.00	\$ 0.00	\$ 0.00	0.00%	\$ 5,593.00	\$ 0.00									
22	3-0500 - Concrete	Concrete 1 Light Pole	\$ 2,298.00	\$ 0.00	\$ 0.00	\$ 0.00	\$ 0.00	0.00%	\$ 2,298.00	\$ 0.00									
23	3-0500 - Concrete	Concrete Slab on Grade - Concrete Pump Support	\$ 39,349.00	\$ 39,349.00	\$ 0.00	\$ 0.00	\$ 39,349.00	100.00%	\$ 0.00										

ITEM NO.	COST CODE	DESCRIPTION OF WORK	SCHEDULED VALUE	WORK COMPLETED		MATERIALS PRESENTLY STORED (NOT IN D OR E)	TOTAL COMPLETED AND STORED TO DATE (D+E+F)	% (G / C)	BALANCE TO FINISH (C - G)	RETAINAGE
				FROM PREVIOUS APPLICATION (D + E)	THIS PERIOD					
24	3-0500 - Concrete	Concrete Generator Pad	\$ 6,143.00	\$ 248.79	\$ 0.00	\$ 0.00	\$ 248.79	4.05%	\$ 5,894.21	\$ 12.44
25	3-0500 - Concrete	Concrete Swales 227 SF / 217 SF	\$ 10,048.00	\$ 293.40	\$ 0.00	\$ 0.00	\$ 293.40	2.92%	\$ 9,754.60	\$ 14.67
26	3-0500 - Concrete	Concrete Wingwall Tank	\$ 49,599.00	\$ 49,599.00	\$ 0.00	\$ 0.00	\$ 49,599.00	100.00%	\$ 0.00	\$ 2,479.95
27	4-0500 - Masonry	Masonry	\$ 32,186.00	\$ 32,186.00	\$ 0.00	\$ 0.00	\$ 32,186.00	100.00%	\$ 0.00	\$ 1,609.30
28	5-0500 - Metals	Labor for Erecting Joist Metals and Metal Deck	\$ 19,239.00	\$ 19,239.00	\$ 0.00	\$ 0.00	\$ 19,239.00	100.00%	\$ 0.00	\$ 961.95
29	5-0500 - Metals	Materials for Joist Beams and Metal Deck	\$ 20,778.00	\$ 20,778.00	\$ 0.00	\$ 0.00	\$ 20,778.00	100.00%	\$ 0.00	\$ 1,038.90
30	5-0500 - Metals	Equipment for Metal Steel	\$ 6,926.00	\$ 6,926.00	\$ 0.00	\$ 0.00	\$ 6,926.00	100.00%	\$ 0.00	\$ 346.30
31	5-0500 - Metals	Miscellaneous Labor	\$ 14,621.00	\$ 14,621.00	\$ 0.00	\$ 0.00	\$ 14,621.00	100.00%	\$ 0.00	\$ 731.05
32	5-0500 - Metals	Miscellaneous Material	\$ 15,930.00	\$ 15,930.00	\$ 0.00	\$ 0.00	\$ 15,930.00	100.00%	\$ 0.00	\$ 796.50
33	7-1113 - Roofing	Moisture-Barrier	\$ 21,451.00	\$ 21,451.00	\$ 0.00	\$ 0.00	\$ 21,451.00	100.00%	\$ 0.00	\$ 1,072.55
34	8-1100 - Metal	Doors & Frames	\$ 23,919.00	\$ 0.00	\$ 0.00	\$ 0.00	\$ 0.00	0.00%	\$ 23,919.00	\$ 0.00
35	8-3300 - Coiling	Doors & Grilles	\$ 9,805.00	\$ 0.00	\$ 0.00	\$ 0.00	\$ 0.00	0.00%	\$ 9,805.00	\$ 0.00
36	9-6700 - Fluid	Applied Flooring	\$ 2,681.00	\$ 0.00	\$ 0.00	\$ 0.00	\$ 0.00	0.00%	\$ 2,681.00	\$ 0.00
37	9-9100 - Painting	Paint Bollards at Generator	\$ 181.00	\$ 0.00	\$ 0.00	\$ 0.00	\$ 0.00	0.00%	\$ 181.00	\$ 0.00
38	9-9100 - Painting	Paint CMU Interior & Exterior Walls at Pump Room	\$ 4,687.00	\$ 0.00	\$ 0.00	\$ 0.00	\$ 0.00	0.00%	\$ 4,687.00	\$ 0.00
39	9-9100 - Painting	Paint Interior Exposed Structural Ceiling and Structure at Pump Room	\$ 3,857.00	\$ 0.00	\$ 0.00	\$ 0.00	\$ 0.00	0.00%	\$ 3,857.00	\$ 0.00
40	9-9100 - Painting	Paint HM Doors and Frames	\$ 268.00	\$ 0.00	\$ 0.00	\$ 0.00	\$ 0.00	0.00%	\$ 268.00	\$ 0.00
41	9-9100 - Painting	Paint Double HM Door and Frame	\$ 536.00	\$ 0.00	\$ 0.00	\$ 0.00	\$ 0.00	0.00%	\$ 536.00	\$ 0.00
42	9-9100 - Painting	Paint HM Frame	\$ 161.00	\$ 0.00	\$ 0.00	\$ 0.00	\$ 0.00	0.00%	\$ 161.00	\$ 0.00
43	9-9100 - Painting	Paint Louvers	\$ 402.00	\$ 0.00	\$ 0.00	\$ 0.00	\$ 0.00	0.00%	\$ 402.00	\$ 0.00
44	9-9100 - Painting	Paint Lintels	\$ 670.00	\$ 0.00	\$ 0.00	\$ 0.00	\$ 0.00	0.00%	\$ 670.00	\$ 0.00
45	9-9100 - Painting	Paint Large Water Storage Tank Exterior	\$ 30,431.00	\$ 0.00	\$ 0.00	\$ 0.00	\$ 0.00	0.00%	\$ 30,431.00	\$ 0.00
46	9-9100 - Painting	Paint Above Ground Well Pump and Piping	\$ 5,785.00	\$ 0.00	\$ 0.00	\$ 0.00	\$ 0.00	0.00%	\$ 5,785.00	\$ 0.00
47	9-9100 - Painting	Paint Equipment for Access to Height	\$ 4,821.00	\$ 0.00	\$ 0.00	\$ 0.00	\$ 0.00	0.00%	\$ 4,821.00	\$ 0.00
48	9-9100 - Painting	Paint Upcharge	\$ 1,500.00	\$ 0.00	\$ 0.00	\$ 0.00	\$ 0.00	0.00%	\$ 1,500.00	\$ 0.00
49	10-1400 - Signage	Signage	\$ 185.00	\$ 0.00	\$ 0.00	\$ 0.00	\$ 0.00	0.00%	\$ 185.00	\$ 0.00

Item-12.

ITEM NO.	COST CODE	DESCRIPTION OF WORK	SCHEDULED VALUE	WORK COMPLETED		MATERIALS PRESENTLY STORED (NOT IN D OR E)	TOTAL COMPLETED AND STORED TO DATE (D+E+F)	% (G / C)	BALANCE TO FINISH (C - G)	RETAINAGE
				FROM PREVIOUS APPLICATION (D + E)	THIS PERIOD					
				Item-12.						
50	22-0500 - Plumbing	Plumbing Management, Submittals, Coordination	\$ 20,994.00	\$ 12,596.40	\$ 0.00	\$ 0.00	\$ 12,596.40	60.00%	\$ 8,397.60	\$ 629.82
51	22-0500 - Plumbing	Plumbing Mobilization	\$ 10,668.00	\$ 10,668.00	\$ 0.00	\$ 0.00	\$ 10,668.00	100.00%	\$ 0.00	\$ 533.40
52	22-0500 - Plumbing	Plumbing Labor - Underground	\$ 20,884.00	\$ 2,088.40	\$ 0.00	\$ 0.00	\$ 2,088.40	10.00%	\$ 18,795.60	\$ 104.42
53	22-0500 - Plumbing	Plumbing Labor - Above Ground	\$ 13,705.00	\$ 3,426.25	\$ 0.00	\$ 0.00	\$ 3,426.25	25.00%	\$ 10,278.75	\$ 171.31
54	22-0500 - Plumbing	Plumbing Demobilization	\$ 2,520.00	\$ 0.00	\$ 0.00	\$ 0.00	\$ 0.00	0.00%	\$ 2,520.00	\$ 0.00
55	22-0500 - Plumbing	Plumbing Material	\$ 212,573.00	\$ 53,143.25	\$ 0.00	\$ 0.00	\$ 53,143.25	25.00%	\$ 159,429.75	\$ 2,657.17
56	22-0500 - Plumbing	Plumbing Equipment Fixtures	\$ 28,305.00	\$ 0.00	\$ 0.00	\$ 0.00	\$ 0.00	0.00%	\$ 28,305.00	\$ 0.00
57	22-0500 - Plumbing	Plumbing Excavation Subcontractor	\$ 79,296.00	\$ 3,964.80	\$ 0.00	\$ 0.00	\$ 3,964.80	5.00%	\$ 75,331.20	\$ 198.24
58	22-0500 - Plumbing	Plumbing Rentals	\$ 5,342.00	\$ 2,671.00	\$ 0.00	\$ 0.00	\$ 2,671.00	50.00%	\$ 2,671.00	\$ 133.55
59	22-0500 - Plumbing	Plumbing Tools Consumables	\$ 9,737.00	\$ 1,460.55	\$ 0.00	\$ 0.00	\$ 1,460.55	15.00%	\$ 8,276.45	\$ 73.03
60	23-0500 - HVAC	HVAC	\$ 25,784.00	\$ 0.00	\$ 0.00	\$ 0.00	\$ 0.00	0.00%	\$ 25,784.00	\$ 0.00
61	26-0500 - Electrical	Electrical Mobilization	\$ 12,610.00	\$ 12,610.00	\$ 0.00	\$ 0.00	\$ 12,610.00	100.00%	\$ 0.00	\$ 630.50
62	26-0500 - Electrical	Electrical Underground	\$ 150,000.00	\$ 141,165.00	\$ 0.00	\$ 0.00	\$ 141,165.00	94.11%	\$ 8,835.00	\$ 7,058.25
63	26-0500 - Electrical	Electrical Distribution	\$ 252,750.00	\$ 0.00	\$ 101,100.00	\$ 0.00	\$ 101,100.00	40.00%	\$ 151,650.00	\$ 5,055.00
64	26-0500 - Electrical	Electrical Lighting	\$ 37,128.00	\$ 0.00	\$ 0.00	\$ 0.00	\$ 0.00	0.00%	\$ 37,128.00	\$ 0.00
65	26-0500 - Electrical	Electrical TIE Control Subcontractor	\$ 77,350.00	\$ 0.00	\$ 0.00	\$ 0.00	\$ 0.00	0.00%	\$ 77,350.00	\$ 0.00
66	31-0500 - Earthwork	Earthwork Mobilization	\$ 12,767.00	\$ 12,767.00	\$ 0.00	\$ 0.00	\$ 12,767.00	100.00%	\$ 0.00	\$ 638.35
67	31-0500 - Earthwork	Earthwork Strip Site	\$ 48,513.00	\$ 48,513.00	\$ 0.00	\$ 0.00	\$ 48,513.00	100.00%	\$ 0.00	\$ 2,425.65
68	31-0500 - Earthwork	Earthwork Access Road	\$ 79,154.00	\$ 79,154.00	\$ 0.00	\$ 0.00	\$ 79,154.00	100.00%	\$ 0.00	\$ 3,957.70
69	31-0500 - Earthwork	Earthwork Laydown Area	\$ 24,257.00	\$ 24,257.00	\$ 0.00	\$ 0.00	\$ 24,257.00	100.00%	\$ 0.00	\$ 1,212.85
70	31-0500 - Earthwork	Earthwork Tank Building Pad	\$ 51,067.00	\$ 51,067.00	\$ 0.00	\$ 0.00	\$ 51,067.00	100.00%	\$ 0.00	\$ 2,553.35
71	31-0500 - Earthwork	Earthwork Generator Building Pad	\$ 12,767.00	\$ 12,767.00	\$ 0.00	\$ 0.00	\$ 12,767.00	100.00%	\$ 0.00	\$ 638.35
72	31-0500 - Earthwork	Earthwork Pump Building Pad	\$ 15,320.00	\$ 15,320.00	\$ 0.00	\$ 0.00	\$ 15,320.00	100.00%	\$ 0.00	\$ 766.00
73	31-0500 - Earthwork	Earthwork Grade Site/Dig Swale	\$ 8,937.00	\$ 446.85	\$ 0.00	\$ 0.00	\$ 446.85	5.00%	\$ 8,490.15	\$ 22.34
74	32-3100 - Fencing & Gates	Fencing & Gates	\$ 36,789.00	\$ 0.00	\$ 0.00	\$ 0.00	\$ 0.00	0.00%	\$ 36,789.00	\$ 0.00
75	33-0500 - Utilities	Utilities - Bank Sand for Waterline	\$ 6,383.00	\$ 6,383.00	\$ 0.00	\$ 0.00	\$ 6,383.00	100.00%	\$ 0.00	\$ 319.15
76	33-0500 - Utilities	Utilities - TS&V for Waterline	\$ 12,767.00	\$ 12,767.00	\$ 0.00	\$ 0.00	\$ 12,767.00	100.00%	\$ 0.00	\$ 638.35

ITEM NO.	COST CODE	DESCRIPTION OF WORK	SCHEDULED VALUE	WORK COMPLETED		MATERIALS PRESENTLY STORED (NOT IN D OR E)	TOTAL COMPLETED AND STORED TO DATE (D+E+F)	% (G / C)	BALANCE TO FINISH (C - G)	RETAINAGE
				FROM PREVIOUS APPLICATION (D + E)	THIS PERIOD					
77	33-0500 - Utilities	Utilities - PVC Pipe & Fittings for Waterline	\$ 63,834.00	\$ 63,834.00	\$ 0.00	\$ 0.00	\$ 63,834.00	100.00%	\$ 0.00	\$ 3,191.70
78	33-0500 - Utilities	Utilities - Labor for Waterline	\$ 25,534.00	\$ 25,534.00	\$ 0.00	\$ 0.00	\$ 25,534.00	100.00%	\$ 0.00	\$ 1,276.70
79	33-0500 - Utilities	Utilities - Equipment for Waterline	\$ 38,300.00	\$ 38,300.00	\$ 0.00	\$ 0.00	\$ 38,300.00	100.00%	\$ 0.00	\$ 1,915.00
80	33-0500 - Utilities	Utilities - Miscellaneous for Waterline	\$ 15,958.00	\$ 15,958.00	\$ 0.00	\$ 0.00	\$ 15,958.00	100.00%	\$ 0.00	\$ 797.90
81	33-0500 - Utilities	Utilities - Mobilization	\$ 15,959.00	\$ 15,959.00	\$ 0.00	\$ 0.00	\$ 15,959.00	100.00%	\$ 0.00	\$ 797.95
82	33-1600 - Storage Tanks- Water	Storage Tanks- Water	\$ 527,000.00	\$ 445,000.00	\$ 0.00	\$ 0.00	\$ 445,000.00	84.44%	\$ 82,000.00	\$ 22,250.00
83	41-2200 - Hoists & Cranes	Hoists & Cranes	\$ 6,384.00	\$ 0.00	\$ 0.00	\$ 0.00	\$ 0.00	0.00%	\$ 6,384.00	\$ 0.00
84	46-0050 - Water & Wastewater Equipment	Water & Wastewater Equipment - Pumps	\$ 46,213.00	\$ 46,213.00	\$ 0.00	\$ 0.00	\$ 46,213.00	100.00%	\$ 0.00	\$ 2,310.65
85	46-0050 - Water & Wastewater Equipment	Chemical Feed - Chlorination Equipment - Vacuum Regulators, Auto Switchover, Out of Gas Switch Assy, Rotometer, Ejector, and Gas Detector	\$ 7,022.00	\$ 0.00	\$ 0.00	\$ 0.00	\$ 0.00	0.00%	\$ 7,022.00	\$ 0.00
86	46-0050 - Water & Wastewater Equipment	Chemical Feed - Accessories- Gauge, Corp Stops, Solenoid Valve	\$ 1,532.00	\$ 0.00	\$ 0.00	\$ 0.00	\$ 0.00	0.00%	\$ 1,532.00	\$ 0.00
87	46-0050 - Water & Wastewater Equipment	Chemical Feed - SCBA and Wall Case	\$ 3,000.00	\$ 0.00	\$ 0.00	\$ 0.00	\$ 0.00	0.00%	\$ 3,000.00	\$ 0.00
88	46-0050 - Water & Wastewater Equipment	Chemical Feed - Dual Cylinder Scale with Storage Chains & Hooks	\$ 2,553.00	\$ 0.00	\$ 0.00	\$ 0.00	\$ 0.00	0.00%	\$ 2,553.00	\$ 0.00
89	46-0050 - Water & Wastewater Equipment	Chemical Feed - Booster Pump	\$ 1,915.00	\$ 0.00	\$ 0.00	\$ 0.00	\$ 0.00	0.00%	\$ 1,915.00	\$ 0.00
90	46-0050 - Water & Wastewater Equipment	Chemical Feed - Beta Pump, Cable, Calibration Column and Pump Skid	\$ 6,320.00	\$ 0.00	\$ 0.00	\$ 0.00	\$ 0.00	0.00%	\$ 6,320.00	\$ 0.00
91	46-0050 - Water & Wastewater Equipment	Chemical Feed - Assman Tanks, (1) 40 Gallon and (1) 250 Gallon	\$ 11,490.00	\$ 0.00	\$ 0.00	\$ 0.00	\$ 0.00	0.00%	\$ 11,490.00	\$ 0.00
92	46-0050 - Water & Wastewater Equipment	Chemical Feed Installation	\$ 6,383.00	\$ 0.00	\$ 0.00	\$ 0.00	\$ 0.00	0.00%	\$ 6,383.00	\$ 0.00

Item-12.

A	B	C	D	E	F	G	H	I	J	
ITEM NO.	COST CODE	DESCRIPTION OF WORK	SCHEDULED VALUE	WORK COMPLETED		MATERIALS PRESENTLY STORED (NOT IN D OR E)	TOTAL COMPLETED AND STORED TO DATE (D+E+F)	% (G / C)	BALANCE TO FINISH (C - G)	RETAINAGE
				FROM PREVIOUS APPLICATION (D + E)	THIS PERIOD					
93	46-0050 - Water & Wastewater Equipment	Chemical Feed Start-Up	\$ 1,277.00	\$ 0.00	\$ 0.00	\$ 0.00	\$ 0.00	0.00%	\$ 1,277.00	\$ 0.00
		TOTALS:	\$ 2,600,000.00	\$ 1,522,257.61	\$ 101,100.00	\$ 0.00	\$ 1,623,357.61	62.44%	\$ 976,642.39	\$ 81,167.91

Item-12.

hole Change Order Packages

A	B	C	D	E	F	G	H	I	J
ITEM NO.	DESCRIPTION OF WORK	SCHEDULED VALUE	WORK COMPLETED		MATERIALS PRESENTLY STORED (NOT IN D OR E)	TOTAL COMPLETED AND STORED TO DATE (D+E+F)	% (G / C)	BALANCE TO FINISH (C - G)	RETAINAGE
			FROM PREVIOUS APPLICATION (D + E)	THIS PERIOD					
4	PCCO#001								
4.1	PCO#003								
4.1.1	31-0500 Additional Lime Subgrade	\$ 22,309.50	\$ 22,309.50	\$ 0.00	\$ 0.00	\$ 22,309.50	100.00%	\$ 0.00	\$ 1,115.48
4.1.2	0-1000 Contractor Fee 5%	\$ 1,115.48	\$ 1,115.48	\$ 0.00	\$ 0.00	\$ 1,115.48	100.00%	\$ 0.00	\$ 55.77
5	PCCO#002								
5.1	PCO#001								
5.1.1	3-0500 Concrete Increase	\$ 812.00	\$ 0.00	\$ 812.00	\$ 0.00	\$ 812.00	100.00%	\$ 0.00	\$ 40.60
5.1.2	5-0500 Steel Increase	\$ 8,350.00	\$ 0.00	\$ 8,350.00	\$ 0.00	\$ 8,350.00	100.00%	\$ 0.00	\$ 417.50
5.1.3	7-1113 Roof Increase	\$ 2,000.00	\$ 0.00	\$ 2,000.00	\$ 0.00	\$ 2,000.00	100.00%	\$ 0.00	\$ 100.00
5.1.4	8-3300 Overhead Door Increase	\$ 2,050.00	\$ 0.00	\$ 2,050.00	\$ 0.00	\$ 2,050.00	100.00%	\$ 0.00	\$ 102.50
5.1.5	26-0500 Commodities Electrical Increase	\$ 71,564.09	\$ 0.00	\$ 71,564.09	\$ 0.00	\$ 71,564.09	100.00%	\$ 0.00	\$ 3,578.20
5.1.6	46-0050 Chemical Feed Increase	\$ 2,900.00	\$ 0.00	\$ 2,900.00	\$ 0.00	\$ 2,900.00	100.00%	\$ 0.00	\$ 145.00
5.1.7	0-1000 Contractor Fee 5%	\$ 4,383.80	\$ 0.00	\$ 4,383.80	\$ 0.00	\$ 4,383.80	100.00%	\$ 0.00	\$ 219.19
6	PCCO#003								
6.1	PCO#005								
6.1.1	22-0500 Plumbing Increase	\$ 63,466.00	\$ 0.00	\$ 57,119.40	\$ 0.00	\$ 57,119.40	90.00%	\$ 6,346.60	\$ 2,855.97
6.1.2	0-1000 Contractor Fee 5%	\$ 3,173.30	\$ 0.00	\$ 2,855.97	\$ 0.00	\$ 2,855.97	90.00%	\$ 317.33	\$ 142.80
	TOTALS:	\$ 182,124.17	\$ 23,424.98	\$ 152,035.26	\$ 0.00	\$ 175,460.24	96.34%	\$ 6,663.93	\$ 8,773.01

and Totals

A	B	C	D	E	F	G	H		
ITEM NO.	DESCRIPTION OF WORK	SCHEDULED VALUE	WORK COMPLETED		MATERIALS PRESENTLY STORED (NOT IN D OR E)	TOTAL COMPLETED AND STORED TO DATE (D+E+F)	% (G / C)	BALANCE TO FINISH (C - G)	RETAINAGE
			FROM PREVIOUS APPLICATION (D + E)	THIS PERIOD					
	GRAND TOTALS:	\$ 2,782,124.17	\$ 1,545,682.59	\$ 253,135.26	\$ 0.00	\$ 1,798,817.85	64.66%	\$ 983,306.32	\$ 89,940.92

Item-12.

DOCUMENT DETAIL SHEET - APPLICATION AND CERTIFICATE FOR PAYMENT



CONDITIONAL WAIVER AND RELEASE ON PROGRESS PAYMENT

Project:	COW – Wharton Well & Water Plant	Job No.	20-0200
----------	----------------------------------	---------	---------

On receipt by E Contractors USA, LLC. of a check from City of Wharton in the sum of \$ 144,433.50 payable to E Contractors USA, LLC. and when the check has been properly endorsed and has been paid by the bank on which it is drawn, this document becomes effective to release any mechanic's lien right, any right arising from a payment bond that complies with a state or federal statute, any common law payment bond right, any claim for payment, and any rights under any similar ordinance, rule, or statute related to claim or payment rights for persons in the signer's position that the signer has on the property of City of Wharton located at 240 CR 222 Wharton, Texas 77488

This release covers a progress payment for all labor, services, equipment, or materials furnished to the property or to City of Wharton. as indicated in the attached statement(s) or progress payment request(s), except for unpaid retention, pending modifications and changes, or other items furnished.

Before any recipient of this document relies on this document, the recipient should verify evidence of payment to the signer. The signer warrants that the signer has already paid or will use the funds received from this progress payment to promptly pay in full all of the signer's laborers, subcontractors, materialmen, and suppliers for all work, materials, equipment, or services provided for or to the above referenced project in regard to the attached statement(s) or progress payment request(s).

Executed this 22nd day of June, 2022

COMPANY NAME: E Contractors USA, LLC.

PRINTED NAME & TITLE: Irfan Abji, Managing Member

SIGNATURE: [Signature]
 Authorized Officer of Sub-Contractor and/or Supplier

ACKNOWLEDGMENT

THE STATE OF TEXAS §
 §
 COUNTY OF FORT BEND §

This instrument was acknowledged before me on this 22nd day of June, 2022,
 by Irfan Abji (Name), Managing Member (Title) of E Contractors
 (Company)

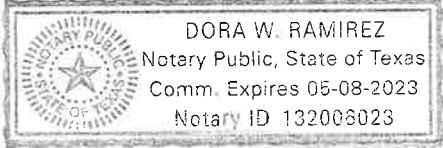

[Signature]
 Notary Public in and for
 The State of TEXAS

City of Wharton
 120 E. Caney Street
 Wharton, TX 77488

CITY COUNCIL COMMUNICATION

Meeting Date:	6/27/2022	Agenda Item:	Pay Request No. 5 and 5a, from Weisinger Inc. for the Wharton Well and Water Plant Contract No. 2 – Well Construction.
<p>Attached you will find Pay Request No. 5 in the amount of \$58,330.00 and 5a in the amount of \$43,182.63, from Weisinger Inc. for the Wharton Well and Water Plant Contract No. 2 – Well Construction.</p> <p>Director of Planning & Development, Gwyn Teves, will be present to answer any questions.</p>			
City Manager: Joseph R. Pace		Date: Thursday, June 23, 2022	
Approval: 			
Mayor: Tim Barker			



City of Wharton

120 E. Caney • Wharton, TX 77488
Phone (979) 532-2491 • Fax (979) 532-0181

MEMORANDUM

DATE: June 21, 2022
FROM: Gwyneth Teves, Director of Planning & Development
TO: Honorable Mayor and City Council
SUBJECT: Recommendation for payment to Weisinger Inc. for the Wharton Well and Water Plant Contract No. 2 – Well Construction Pay Estimate No. 5 & 5a

The City Council awarded a contract for construction to Weisinger Inc for the Wharton Well and Water Plant Contract No. 2 – Well Construction.

Pay Estimate No. 5 & 5a have been sent and recommendation for payment by the engineer is attached.

It is my recommendation that the City Council approve Pay Estimate 5 for \$58,330.00 and Pay Estimate 5a for \$43,182.63 and recommend payment.

If you should have any questions, please contact me at 979-532-2491 ext. 238. Thank You.



June 15, 2022
AVO31934.001

Mr. Anthony Arcidiacono
City of Wharton
120 E. Caney Street
Wharton, TX, 77488

**RE: Wharton Well and Water Plant
Contract No. 2 – Well Construction
Pay Estimate No. 5 & 5a – April - May 2022**

Dear Mr. Arcidiacono,

Weisinger Incorporated has submitted the following pay estimate for the above-referenced project:

Pay Estimate No.:	5	Pay Estimate No.:	5a
Dated:	6/09/2022	Dated:	6/09/2022
For Work Period:	3/20/22 through 5/25/2022	For:	Change Order 2 Price Increase
Balance Due:	\$58,330.00	Balance Due:	\$43,182.63

Half Associates and R.W. Harden reviewed the estimate and recommend it for payment.

Please call me at 713 380 4377 if you have any questions or comments.

Sincerely,
HALFF ASSOCIATES, INC.

A handwritten signature in blue ink that reads "Vincent M. Pena".

Vincent M. Pena, PE
Construction Manager

cc: Gwyneth Teves, City of Wharton
Amy Horelica, City of Wharton
Megan Morris, USDA
Eric Caudill, City Inspector
Tim E. Lackey, Half Project Manager

June 9, 2022

Mr. Tim E. Lackey, P.E.
Vice President
Halff Associates, Inc.
12225 Greenville Ave #200
Dallas, Texas 75243

Re: Weisinger Incorporated Pay Request #5 and #5A
Wharton Well and Water Plant — Contract No. 2, Well Construction (Well No. 5)

Dear Mr. Lackey,

R. W. Harden & Associates, Inc. (RWH&A) has reviewed Weisinger Incorporated's Pay Request #5 and #5A that were submitted for review and provided in Attachments 1 and 2. Pay Request #5 contains the invoice for tasks completed from March 20, 2022 to May 25, 2022. Tasks completed to date includes portions of *Article 11 – Price for Work and Method of Payment, Item F*. for well development, well testing, and water quality sampling. Pay Request #5A contains the invoice for the material price increase through the approved Change Order No. 3 to be paid by the City of Wharton.

To date, the well has been constructed, developed, and tested with material in place and the guarantees per the specifications have been met. Although RWH&A does not typically recommend partial payment, RWH&A can confirm that this work has been completed. Based on RWH&A's review and field records, we concur with Weisinger's Pay Request #5 in the amount of \$58,330.00, which includes 5% retainage, and recommends payment to Weisinger Incorporated. In addition, per the approved Change Order No. 3, RWH&A recommends payment to Weisinger Incorporated for Pay Request #5A in the amount of \$43,182.63, which includes 5% retainage.

If you have any questions, please do not hesitate to contact us.

Sincerely,

Elizabeth Ferry, P.G.
R. W. Harden & Associates, Inc.

Cc: Mr. Vincent Pena, P.E., Halff Associates, Inc.
Mr. Mark Harkness, P.E., Harkness Engineering and Consulting, LLC

**ATTACHMENT 1 –
WEISINGER INCORPORATED PAY REQUEST #5**



Contractor's Application for Payment No. 5

Application Period: 3/20/2022 - 5/25/2022		Application Date: 5/25/2022	
To (Owner): City of Wharton	From (Contractor): Weisinger Incorporated	Via (Engineer): R. W. Harden & Associates, Inc	
Project: Wharton Well and Water Plant	Contract: Contract 2 - Well Construction (Well No. 5)		
Owner's Contract No.: CFDA No. 10 760	Contractor's Project No.: 2851	Engineer's Project No.: 31934	

**Application For Payment
Change Order Summary**

Approved Change Orders		
Number	Additions	Deductions
TOTALS		
NFT CHANGE BY		
CHANGE ORDERS		

1. ORIGINAL CONTRACT PRICE.....	\$ 982,800.00
2. Net change by Change Orders.....	\$ 0.00
3. Current Contract Price (Line 1 + 2).....	\$ 982,800.00
4. TOTAL COMPLETED AND STORED TO DATE (Column F total on Progress Estimates).....	\$ 760,400.00
5. RETAINAGE:	
a. X 5% Work Completed.....	\$ 38,020.00
b. X 15% Stored Material.....	\$ 0.00
c. Total Retainage (Line 5.a + Line 5.b).....	\$ 38,020.00
6. AMOUNT ELIGIBLE TO DATE (Line 4 - Line 5.c).....	\$ 722,380.00
7. LESS PREVIOUS PAYMENTS (Line 6 from prior Application).....	\$ 664,050.00
8. AMOUNT DUE THIS APPLICATION.....	\$ 58,330.00
9. BALANCE TO FINISH, PLUS RETAINAGE (Column G total on Progress Estimates + Line 5.c above).....	\$ 222,400.00

Contractor's Certification
 The undersigned Contractor certifies, to the best of its knowledge, the following:
 (1) All previous progress payments received from Owner on account of Work done under the Contract have been applied on account to discharge Contractor's legitimate obligations incurred in connection with the Work covered by prior Applications for Payment;
 (2) Title to all Work, materials and equipment incorporated in said Work, or otherwise listed in or covered by this Application for Payment, will pass to Owner at time of payment free and clear of all Liens, security interests, and encumbrances (except such as are covered by a bond acceptable to Owner indemnifying Owner against any such Liens, security interest, or encumbrances), and
 (3) All the Work covered by this Application for Payment is in accordance with the Contract Documents and is not defective.

Contractor Signature
 By:  Date: 5/25/2022

Payment of \$ 58,330.00
 (Line 8 or other - attach explanation of the other amount)

is recommended by: Mark Hardness June 9, 2022
 (Engineer) (Date)

Payment of \$ _____
 (Line 8 or other - attach explanation of the other amount)

is approved by _____ (Date)
 (Owner)

Approved by _____ (Date)
 Funding or Financing Entity (if applicable)



P.O. Box 909
Willis, Tx 77378

(936)756-7721 info@weisingerinc.com
(936)756-7723 www.weisingerinc.com

Item-13.

Invoice

Date	Invoice #
6/6/2022	32256

Bill To
R.W. Harden & Associates, Inc. 9009 Mountain Ridge Dr. Suite 100 Austin, Tx. 78759

City of Wharton 120 East Caney Street Wharton, TX 77488

P.O. No.	Terms
	Due on receipt

Quantity	Description	Rate	Amount
1	City of Wharton- Well 5 Pay Request 5	61,400.00	61,400.00
	5% DEDUCTION FOR RETAINAGE	-5.00%	-3,070.00

Subtotal	\$58,330.00
Sales Tax (0.0%)	\$0.00
Total	\$58,330.00

Project: City of Wharton - Well 5

Job No.: Contract 2

Owner: City of Wharton

Project Manager: Seth Flynt
 Engineer: R.W. Harden & Associates, Inc.

Contractor: Weisinger Incorporated

Application Date: 5/25/2022 Application No:

Period From: 3/20/2022 To: 5/25/2022

CHANGE ORDER SUMMARY

Change orders approved in previous months by Owner		Additions \$	Deletions \$
Subsequent Change Orders			
Number	Approved (date)		
CO1	11/22/2022	\$0.00	\$0.00
CO2	11/22/2022	\$0.00	\$0.00
CO3	5/23/2022	\$98,595.11	
Net Change by Change Orders			\$98,595.11

Application is made for payment, as shown below attached Contract Certification Sheet(s).

The present status of the account for this contract is:

Original Contract Sum

Net Changes by Change Order

Contract Sum to Date

Total Completed and Stored to Date

Retainage 5%

Total less Retainage

Less Previous Certificates for Payment

Current Payment Due

Weather Days Requested to Date: Weather Days Granted:
 Liquidated Damages Assessed: None

The undersigned Contractor certifies that the work covered by the Application for Payment has been completed in accordance with the Contract Documents, that all amounts have been paid by him for Work for which previous Certificates for Payment were issued and payment received from the owner and that the current payment shown herein is now due.

In accordance with the Contract and this Application for Payment, the Contractor is entitled to pay in the amount shown above

Contractor: Weisinger Incorporated

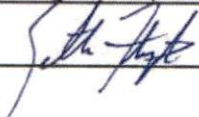
Signed by: 

Engineer: Mark Harkness, P.E.

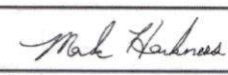
Signed by:  Date:

Job: City of Wharton - Well 5
 Contractor: Weisinger Incorporated
 Owner: City of Wharton

Date
 Pay F

From: 3/20/2022 To: 5/25/2022

Item No.	Description of Work	Unit	Plan Quantity	Unit Price	TOTAL contract Amount	Quantity Prev. Billed	Quantity This Period	Amount Due this Estimate
BASE BID								
1	Mobilization and Demobilization	LS	1	\$ 150,000.00	\$ 150,000.00	0.5	0	\$ -
2	Test Hole to 1600 ft and Logging	LS	1	\$ 265,000.00	\$ 265,000.00	1	0	\$ -
3	Temporary Well 1	LS	1	\$ 75,000.00	\$ 75,000.00	1	0	\$ -
4	Temporary Well 2	LS	1	\$ 65,000.00	\$ 65,000.00	1	0	\$ -
5	Temporary Well 3	LS	1	\$ 55,000.00	\$ 55,000.00	1	0	\$ -
6	18" Production Well	LS	1	\$ 234,600.00	\$ 234,600.00	0.73188406	0.26172208	\$ 61,400.00
7	Pump Foundation	LS	1	\$ 15,000.00	\$ 15,000.00	0	0	\$ -
8	Pumping Equipment	LS	1	\$ 110,000.00	\$ 110,000.00	0	0	\$ -
9	Bonds	LS	1	\$ 13,200.00	\$ 13,200.00	1	0	\$ -
ALTERNATE BID								
1	Mobilization and Demobilization	LS	1	\$ 150,000.00	\$ 150,000.00	0	0	\$ -
2	Test Hole to 1600 ft and Logging	LS	1	\$ 265,000.00	\$ 265,000.00	0	0	\$ -
3	Temporary Well 1	LS	1	\$ 75,000.00	\$ 75,000.00	0	0	\$ -
4	Temporary Well 2	LS	1	\$ 65,000.00	\$ 65,000.00	0	0	\$ -
5	Temporary Well 3	LS	1	\$ 55,000.00	\$ 55,000.00	0	0	\$ -
6	18"x12" Production Well	LS	1	\$ 415,200.00	\$ 415,200.00	0	0	\$ -
7	Pump Foundation	LS	1	\$ 15,000.00	\$ 15,000.00	0	0	\$ -
8	Pumping Equipment	LS	1	\$ 140,000.00	\$ 140,000.00	0	0	\$ -
9	Bonds	LS	1	\$ 15,300.00	\$ 15,300.00	0	0	\$ -
ADD / DEDUCT								
B	Add/Deduct Test Hole	LS	1	\$ 50.00	\$ 50.00	0	0	\$ -
C	Add/Deduct Plugging Test Hole	LS	1	\$ 15.00	\$ 15.00	0	0	\$ -
D	Add/Deduct Sieve Analysis	LS	1	\$ 5.00	\$ 5.00	0	0	\$ -
E	Add for Cement Plug	LS	1	\$ 8,000.00	\$ 8,000.00	1	0	\$ -
F	Add/Deduct Per Sack Cement Plug	LS	1	\$ 20.00	\$ 20.00	0	0	\$ -
G	Add/Deduct 10" Casing for Temp Well	LS	1	\$ 2.00	\$ 2.00	0	0	\$ -
H	Add/Deduct 6" Screen for Temp Well	LS	1	\$ 5.00	\$ 5.00	0	0	\$ -
I	Add/Deduct Temp Well Pump Time + or - 24 Hrs	LS	1	\$ 350.00	\$ 350.00	0	0	\$ -
J	Add for Temp Pump in Base Bid Well	LS	1	\$ 65,000.00	\$ 65,000.00	0	0	\$ -
K	Add for Temp Pump in Alt Bid Well	LS	1	\$ 80,000.00	\$ 80,000.00	0	0	\$ -
L	Add/Deduct Conductor	LS	1	\$ 200.00	\$ 200.00	0	0	\$ -
M	Add/Deduct 18" Casing	LS	1	\$ 170.00	\$ 170.00	55	0	\$ -
N	Add/Deduct 18" Screen	LS	1	\$ 450.00	\$ 450.00	-85	0	\$ -
O	Add/Deduct 18" Alt Bid Casing	LS	1	\$ 170.00	\$ 170.00	0	0	\$ -
P	Add/Deduct 12" Blank	LS	1	\$ 190.00	\$ 190.00	0	0	\$ -
Q	Add/Deduct 12" Screen	LS	1	\$ 300.00	\$ 300.00	0	0	\$ -
R	Add/Deduct Per Hour of Well Testing 36 HR	LS	1	\$ 300.00	\$ 300.00	0	0	\$ -
S	Add/Deduct Per Hour of Well Recovery 12 HR	LS	1	\$ 200.00	\$ 200.00	0	0	\$ -
T	Add/Deduct Per 100 ft of Discharge Hose	LS	1	\$ 5,000.00	\$ 5,000.00	0	0	\$ -
U	Add Per Hour Development Time	LS	1	\$ 300.00	\$ 300.00	0	0	\$ -
V	Add/Deduct Base Bid Pump Stage	LS	1	\$ 2,850.00	\$ 2,850.00	0	0	\$ -
W	Add/Deduct Base Bid Per 60 HP	LS	1	\$ 5,000.00	\$ 5,000.00	0	0	\$ -
X	Add/Deduct Base Bid 12" Column	LS	1	\$ 130.00	\$ 130.00	0	0	\$ -
Y	Add/Deduct Alt Bid Pump Stage	LS	1	\$ 2,850.00	\$ 2,850.00	0	0	\$ -

Item No.	Description of Work	Unit	Plan		TOTAL contract Amount	Quantity		Amount Due this Estimate	To
			Quantity	Unit Price		Prev. Billed	This Period		
Z	Add/Deduct Alt Bid Per 50 HP	LS	1	\$ 8,500.00	\$ 8,500.00	0	0	\$ -	
AA	Add/Deduct Alt Bid 12" Column	LS	1	\$ 130.00	\$ 130.00	0	0	\$ -	
BB	Add Per 100 ft of Camera Survey Base Bid	LS	1	\$ 250.00	\$ 250.00	0	0	\$ -	
CC	Add Per 100 ft of Camera Survey Alt Bid	LS	1	\$ 250.00	\$ 250.00	0	0	\$ -	
DD	Add Per Hour Rig Time	LS	1	\$ 550.00	\$ 550.00	0	0	\$ -	
EE	Add Per Hour Standby Time	LS	1	\$ 500.00	\$ 500.00	0	0	\$ -	
Change Order									
1	18" Casing Increase	LS	1	\$ 13,652.50	\$ 13,652.50	0	0	\$ -	
2	18" Stainless Steel Increase	LS	1	\$ 24,025.00	\$ 24,025.00	0	0	\$ -	
3	18" Stainless Steel Screen Increase	LS	1	\$ 3,450.00	\$ 3,450.00	0	0	\$ -	
4	Cement Increase	LS	1	\$ 4,327.90	\$ 4,327.90	0	0	\$ -	
5	Pump Stages Increase	LS	1	\$ 3,623.04	\$ 3,623.04	0	0	\$ -	
6	Motor Increase	LS	1	\$ 861.44	\$ 861.44	0	0	\$ -	
7	Column Assembly Increase	LS	1	\$ 35,795.00	\$ 35,795.00	0	0	\$ -	
8	15% Allowable Markup on Increase	LS	1	\$ 12,860.23	\$ 12,860.23	0	0	\$ -	

Contract Total \$982,800.00

Subtotal this estimate \$ 61,400.00
 Less 5% \$ 3,070.00
 Subtotal \$ 58,330.00
 Plus reduced retainage \$ -
 Total amount Due \$ 58,330.00

 Seth Flint - Project Manager
 Welsinger Incorporated

City of Wharton - Well 5
Schedule of Value

Task Description	Value	In Pla
Bid Item No. 6 - 18" Production Well		
Ream pilot hole	\$ 62,500.00	\$ 62,500.00
Install 18" casing/blank/screen	\$ 93,400.00	\$ 93,400.00
Develop well with drilling rig	\$ 31,600.00	\$ 31,600.00
Install test pump, develop with test pump, step tests, and 36 hour test	\$ 39,100.00	\$ 39,100.00
Water quality analysis and bac-t samples	\$ 6,500.00	\$ 6,500.00
Camera survey	\$ 1,500.00	\$ -
TOTAL AMOUNT	\$ 234,600.00	\$ 233,100.00

ATTACHMENT 2 –
WEISINGER INCORPORATED PAY REQUEST #5A



P.O. Box 909
Willis, Tx 77378

(936)756-7721 info@weisingerinc.com
(936)756-7723 www.weisingerinc.com

Item-13.
Invoice

Date	Invoice #
6/6/2022	32257

Bill To
R.W. Harden & Associates, Inc. 9009 Mountain Ridge Dr. Suite 100 Austin, Tx. 78759

City of Wharton 120 East Caney Street Wharton, TX 77488

P.O. No.	Terms
----------	-------

	Due on receipt
--	----------------

Quantity	Description	Rate	Amount
1	City of Wharton-Well 5 Pay Request #5A	45,455.40	45,455.40
	5% DEDUCTION FOR RETAINAGE	-5.00%	-2,272.77

Subtotal	\$43,182.63
Sales Tax (0.0%)	\$0.00
Total	\$43,182.63

Project: City of Wharton - Well 5

Job No.: Contract 2

Owner: City of Wharton

Project Manager: Seth Flynt
 Engineer: R.W. Harden & Associates, Inc.

Contractor: Weisinger Incorporated

Application Date: 5/25/2022 Application No:

Period From: 3/20/2022 To: 5/25/2022

CHANGE ORDER SUMMARY

Change orders approved in previous months by Owner		Additions \$	Deletions \$
Subsequent Change Orders			
Number	Approved (date)		
CO1	11/22/2022	\$0.00	\$0.00
CO2	11/22/2022	\$0.00	\$0.00
CO3	5/23/2022	\$98,595.11	

Net Change by Change Orders \$98,595.11

Weather Days Requested to Date: Weather Days Granted:

Liquidated Damages Assessed: None

The undersigned Contractor certifies that the work covered by the Application for Payment has been completed in accordance with the Contract Documents, that all amounts have been paid by him for Work for which previous Certificates for Payment were issued and payment received from the owner and that the current payment shown herein is now due.

Contractor: Weisinger Incorporated

Signed by: 

Application is made for payment, as shown below attached Contract Certification Sheet(s).

The present status of the account for this contract is:

Original Contract Sum

Net Changes by Change Order

Contract Sum to Date

Total Completed and Stored to Date

Retainage 5%

Total less Retainage

Less Previous Certificates for Payment

Current Payment Due

In accordance with the Contract and this Application for Payment, the Contractor is entitled to payment in the amount shown above

Engineer: Mark Harkness, P.E.

Signed by:  Date:

Job: City of Wharton - Well 5
 Contractor: Weisinger Incorporated
 Owner: City of Wharton

Date
 Pay F

From: 3/20/2022 To: 5/25/2022

Item No.	Description of Work	Unit	Plan Quantity	Unit Price	TOTAL contract Amount	Quantity Prev. Billed	Quantity This Period	Amount Due this Estimate
BASE BID								
1	Mobilization and Demobilization	LS	1	\$ 150,000.00	\$ 150,000.00	0.5	0	\$ -
2	Test Hole to 1600 ft and Logging	LS	1	\$ 265,000.00	\$ 265,000.00	1	0	\$ -
3	Temporary Well 1	LS	1	\$ 75,000.00	\$ 75,000.00	1	0	\$ -
4	Temporary Well 2	LS	1	\$ 65,000.00	\$ 65,000.00	1	0	\$ -
5	Temporary Well 3	LS	1	\$ 55,000.00	\$ 55,000.00	1	0	\$ -
6	18" Production Well	LS	1	\$ 234,600.00	\$ 234,600.00	0.99360614	0	\$ -
7	Pump Foundation	LS	1	\$ 15,000.00	\$ 15,000.00	0	0	\$ -
8	Pumping Equipment	LS	1	\$ 110,000.00	\$ 110,000.00	0	0	\$ -
9	Bonds	LS	1	\$ 13,200.00	\$ 13,200.00	1	0	\$ -
ALTERNATE BID								
1	Mobilization and Demobilization	LS	1	\$ 150,000.00	\$ 150,000.00	0	0	\$ -
2	Test Hole to 1600 ft and Logging	LS	1	\$ 265,000.00	\$ 265,000.00	0	0	\$ -
3	Temporary Well 1	LS	1	\$ 75,000.00	\$ 75,000.00	0	0	\$ -
4	Temporary Well 2	LS	1	\$ 65,000.00	\$ 65,000.00	0	0	\$ -
5	Temporary Well 3	LS	1	\$ 55,000.00	\$ 55,000.00	0	0	\$ -
6	18"x12" Production Well	LS	1	\$ 415,200.00	\$ 415,200.00	0	0	\$ -
7	Pump Foundation	LS	1	\$ 15,000.00	\$ 15,000.00	0	0	\$ -
8	Pumping Equipment	LS	1	\$ 140,000.00	\$ 140,000.00	0	0	\$ -
9	Bonds	LS	1	\$ 15,300.00	\$ 15,300.00	0	0	\$ -
ADD / DEDUCT								
B	Add/Deduct Test Hole	LS	1	\$ 50.00	\$ 50.00	0	0	\$ -
C	Add/Deduct Plugging Test Hole	LS	1	\$ 15.00	\$ 15.00	0	0	\$ -
D	Add/Deduct Sieve Analysis	LS	1	\$ 5.00	\$ 5.00	0	0	\$ -
E	Add for Cement Plug	LS	1	\$ 8,000.00	\$ 8,000.00	1	0	\$ -
F	Add/Deduct Per Sack Cement Plug	LS	1	\$ 20.00	\$ 20.00	0	0	\$ -
G	Add/Deduct 10" Casing for Temp Well	LS	1	\$ 2.00	\$ 2.00	0	0	\$ -
H	Add/Deduct 6" Screen for Temp Well	LS	1	\$ 5.00	\$ 5.00	0	0	\$ -
I	Add/Deduct Temp Well Pump Time + or - 24 Hrs	LS	1	\$ 350.00	\$ 350.00	0	0	\$ -
J	Add for Temp Pump in Base Bid Well	LS	1	\$ 65,000.00	\$ 65,000.00	0	0	\$ -
K	Add for Temp Pump in Alt Bid Well	LS	1	\$ 80,000.00	\$ 80,000.00	0	0	\$ -
L	Add/Deduct Conductor	LS	1	\$ 200.00	\$ 200.00	0	0	\$ -
M	Add/Deduct 18" Casing	LS	1	\$ 170.00	\$ 170.00	55	0	\$ -
N	Add/Deduct 18" Screen	LS	1	\$ 450.00	\$ 450.00	-85	0	\$ -
O	Add/Deduct 18" Alt Bid Casing	LS	1	\$ 170.00	\$ 170.00	0	0	\$ -
P	Add/Deduct 12" Blank	LS	1	\$ 190.00	\$ 190.00	0	0	\$ -
Q	Add/Deduct 12" Screen	LS	1	\$ 300.00	\$ 300.00	0	0	\$ -
R	Add/Deduct Per Hour of Well Testing 36 HR	LS	1	\$ 300.00	\$ 300.00	0	0	\$ -
S	Add/Deduct Per Hour of Well Recovery 12 HR	LS	1	\$ 200.00	\$ 200.00	0	0	\$ -
T	Add/Deduct Per 100 ft of Discharge Hose	LS	1	\$ 5,000.00	\$ 5,000.00	0	0	\$ -
U	Add Per Hour Development Time	LS	1	\$ 300.00	\$ 300.00	0	0	\$ -
V	Add/Deduct Base Bid Pump Stage	LS	1	\$ 2,850.00	\$ 2,850.00	0	0	\$ -
W	Add/Deduct Base Bid Per 50 HP	LS	1	\$ 5,000.00	\$ 5,000.00	0	0	\$ -
X	Add/Deduct Base Bid 12" Column	LS	1	\$ 130.00	\$ 130.00	0	0	\$ -
Y	Add/Deduct Alt Bid Pump Stage	LS	1	\$ 2,850.00	\$ 2,850.00	0	0	\$ -

City of Wharton
 120 E. Caney Street
 Wharton, TX 77488

CITY COUNCIL COMMUNICATION

Meeting Date:	6/27/2022	Agenda Item:	Resolution: A resolution of the Wharton City Council approving the dissolution of the City of Wharton Housing Finance Corporation; authorizing the preparation and execution of all documents necessary to dissolve the corporation; and authorizing the Mayor of the City of Wharton to execute all documents related to the dissolution.
<p>The City Council, by resolution, created the Wharton Housing Finance Corporation on April 23, 2018, to assist with financing the cost of residential ownership and development that would provide decent safe and sanitary housing that are functionally related to any affordable housing project, at affordable prices for residents of the City.</p> <p>The Corporation has not been able to provide any financial assistance to date and the City is pending development of three (3) affordable multifamily housing projects and several housing development projects coming into the City.</p> <p>It has been difficult to keep the members engaged and meetings have not been held regularly due to lack of items of business. The Corporation has had vacant positions for over a year that have not been able to be filled.</p> <p>It is the City Staff's recommendation, that per the Article of Incorporation of the Wharton Housing Finance Corporation (attached), that the City Council by written resolution may authorize and direct the dissolution of the Corporation.</p> <p>Attached is the draft resolution for the dissolution of the Wharton Housing Finance Corporation.</p> <p>Director of Planning & Development, Gwyn Teves, will be present to answer any questions.</p>			
City Manager: Joseph R. Pace		Date: Thursday, June 23, 2022	
Approval: 			
Mayor: Tim Barker			



City of Wharton

120 E. Caney • Wharton, TX 77488
Phone (979) 532-2491 • Fax (979) 532-0181

MEMORANDUM

DATE: June 21, 2022

FROM: Gwyneth Teves, Director of Planning & Development (Executive Director of WHFC)

TO: Honorable Mayor and City Council

SUBJECT: Recommendation for termination of the Wharton Housing Finance Corporation (WHFC)

The City Council by resolution created the Wharton Housing Finance Corporation on April 23rd, 2018, to assist with financing the cost of residential ownership and development that will provide decent safe and sanitary housing that are functionally related to any affordable housing project, at affordable prices for residents of the City.

The Corporation has not been able to provide any financial assistance to date and the City is pending development of 3 affordable multifamily housing projects and several housing development projects coming into the city.

It has been difficult to keep the members engaged and meetings have not been held regularly due to lack of items of business. We have had vacant positions for over a year that have not been able to be filled.

It is my recommendation that per the Article of Incorporation of the Wharton Housing Finance Corporation (attached) that the City Council by written resolution may authorize and direct the dissolution of the Corporation.

Attached is the draft resolution for the dissolution of the Wharton Housing Finance Corporation.

If you should have any questions, please contact me at 979-532-2491 ext. 238. Thank You.

**ARTICLES OF INCORPORATION
OF
CITY OF WHARTON
HOUSING FINANCE CORPORATION**

We, the undersigned natural persons, each of whom is at least eighteen (18) years of age or more, and a resident and qualified voter of the City of Wharton, Texas (the *City*) and a citizen of the State of Texas (the *State*), acting as incorporators of a nonprofit corporation under the provisions of Chapter 394, as amended, Texas Local Government Code (the *Act*), do hereby adopt the following articles of incorporation for such corporation (the *Articles of Incorporation*):

ARTICLE I

The name of the corporation is CITY OF WHARTON HOUSING FINANCE CORPORATION (the *Corporation*).

ARTICLE II

The Corporation is a public, nonprofit corporation.

ARTICLE III

Subject to the provisions of Article XVII, the period of duration of the Corporation shall be perpetual.

ARTICLE IV

The Corporation is organized solely to carry out the purposes of the Act and, specifically, aiding, assisting, and acting on behalf of and for the benefit of the City in the performance of its governmental functions, including providing a means for financing the cost of residential ownership and development that will provide decent, safe, and sanitary housing, including non-housing facilities that are an integral part of or are functionally related to any affordable housing project, at affordable prices for residents of the City.

The Corporation is formed pursuant to the provisions of the Act as it now or may hereafter be amended, which authorizes the Corporation to assist and act on behalf of the City and to engage in activities in furtherance of the purpose for its creation.

The Corporation shall have all powers incidental to or necessary for the performance of the powers prescribed by Subchapter D of the Act, as now or hereafter provided, and may exercise other powers necessary or appropriate to carry out the purposes for which the Corporation is organized. To the extent necessary to carry out its purposes, the Corporation shall also have and exercise all of the rights, powers, privileges, authority, and functions given by the general laws of the State to nonprofit corporation incorporated under the Act. The Corporation shall have all other powers of a like or different nature not prohibited by law which are available to non-profit corporations in the State and which are necessary or useful to enable the Corporation to perform the purposes for which it is created.

The Corporation is created as a housing finance corporation pursuant to the Act and shall constitute a public instrumentality and a nonprofit corporation under the name stated herein. The

Corporation does not constitute a municipality, county, or other political corporation or subdivision of the State of Texas (the *State*). The Corporation shall not exercise the powers of sovereignty of the City, including the power to tax, eminent domain power, or police power.

ARTICLE V

The Corporation shall have no members and shall have no stock.

ARTICLE VI

All powers of the Corporation shall be vested in a board of directors (the Board) consisting of seven (7) directors and who shall be, from time to time, nominated by members of the City of Wharton city council (the City Council). Each City Council member will nominate one member of the Board for consideration and approval by the City Council. Each Board member must reside within the district boundaries of the City Council member nominating him/her to the Board. A director nominated by the mayor or a City Council at-large position must reside within the city limits of the City of Wharton. The Director Positions are identified in Article XIV hereof and will serve staggered two (2) year terms. Terms begin on July 1st and expire on June 30th two years thereafter.

The terms for the Directors originally appointed to Director Positions 1, 3, and 5 will expire on June 30, 2019, and the Directors subsequently appointed to these positions will thereafter serve two (2) year terms. The terms for the Directors originally appointed to Director Positions 2, 4, 6, and 7 will expire on June 20, 2020, and the Directors subsequently appointed to these positions will thereafter serve two (2) year terms.

In the event of a Board vacancy, the City Council member for the corresponding district will nominate a replacement for consideration and approval by the City Council. In the event the corresponding City Council seat is also vacant, then the Mayor will nominate a replacement for consideration and approval of the City Council. A Board director may be removed from office for cause or at will as provided by the bylaws of the Corporation.

ARTICLE VII

In the exercise of the powers of the Corporation, the Corporation may enter into any loan, lease, trust, operating, or other agreements, and may lend money for its corporate purposes, as authorized by the Act that are necessary and appropriate to the fulfillment of the Corporation's purpose as set forth in Article IV hereof.

ARTICLE VIII

The City Council has, by resolution adopted on the 23rd day of April, 2018, authorized the creation of the Corporation and approved the Corporation's Articles of Incorporation as a housing finance corporation pursuant to the Act.

To the extent necessary to carry out its purposes, the Corporation shall have and exercise all of the rights, powers, privileges, authority, and functions given under the Act and under the general laws of the State, together with all powers incidental thereto or necessary therefor.

The Corporation is a constituted authority and a public instrumentality within the meaning of the regulations of the United States Treasury Department and the rulings of the Internal Revenue Service prescribed and promulgated pursuant to section 103 of the Internal Revenue Code of 1986, as amended (the *Code*) and the Corporation is authorized to act on behalf of the City as provided in these Articles of

Incorporation. However, the Corporation is not a political subdivision or political corporation of the State within the meaning of the State constitution and laws, including, without limitation, Article III, Section 52 of the State Constitution, and no agreements, bonds, debts, or obligations of the Corporation are or shall ever be deemed to be the agreements, bonds, debts, or obligations, or the lending of credit, or a grant of public money or thing of value, of or by the City, except as provided by State law, or any other political corporation, subdivision, or agency of the State, or a pledge of the faith and credit of any of them.

ARTICLE IX

The Corporation shall be subject to the Open Meetings Act, as amended, Tex. Gov't Code § 551.001 et seq. and the Open Records Act, as amended, Tex. Gov't Code § 552.001 et seq., in the same manner as if the Corporation were a political subdivision.

ARTICLE X

The initial Bylaws of the Corporation shall be adopted by the Board and shall, together with these Articles of Incorporation, govern the initial affairs of the Corporation until and unless amended in accordance with the provisions of the Act and these Articles of Incorporation.

ARTICLE XI

All powers of the Corporation shall be vested in the Board, which shall consist of seven (7) persons (each of whom shall at all times have the qualifications set forth within these Articles of Incorporation). The initial directors of the Corporation (the *Director* or *Directors*) shall be those seven (7) persons named in Article XIV hereof.

The initial President of the Board shall be David Voulgaris.

ARTICLE XII

All other matters pertaining to the internal affairs of the Corporation shall be governed by the Bylaws of the Corporation, so long as such Bylaws are not inconsistent with these Articles of Incorporation or the laws of the State.

ARTICLE XIII

The street address of the initial registered office of the Corporation is 120 East Caney Street Wharton, Texas 77488, and the name of the initial registered agent at such address is 120 East Caney Street Wharton, Texas 77488.

ARTICLE XIV

The number of Directors initially constituting the Board is seven (7). The names, addresses, and City Council district nominating the director are listed below:

dissolution of the Corporation, after the payment or satisfaction of all debts, liabilities and obligations, all assets will be turned over to the City, or its successor, unless the City Council shall otherwise direct.

ARTICLE XVIII

To the fullest extent permitted by law, the Corporation, without the affirmative vote of the entire Board, shall not (a) institute any proceedings to adjudicate the Corporation as bankrupt or insolvent, (b) consent to the institution of bankruptcy or insolvency proceedings against the Corporation, (c) file a petition seeking or consenting to reorganization or relief under any applicable federal or state law relating to the bankruptcy with respect to the Corporation, (d) consent to the appointment of a receiver, liquidator, assignee, trustee, sequestrator (or other similar official) of the Corporation or a substantial part of its property, (e) make any assignment for the benefit of the Corporation's creditors, (t) cause the Corporation to admit in writing its inability to pay its debts generally as they become due; or (g) take any action, or cause the Corporation to take any action, in furtherance of any of the foregoing (any of the above foregoing actions, a *Bankruptcy Action*). No Director or officer of the Corporation shall (to the extent permitted by applicable law) be liable to the Corporation on account of such Director's or officer's good faith reliance on the provisions of this Article XVIII and the Corporation shall not have any claim for breach of fiduciary duty or otherwise against any Director or officer for failing to take any Bankruptcy Action.

ARTICLE XIX

A. The City Council, by written resolution (and in addition to the right of the Board to direct the Corporation's dissolution as provided in Article XVII), may authorize and direct the dissolution of the Corporation. However, the Corporation shall not be dissolved or liquidated, and its business shall not be terminated, by act of the City Council or otherwise, so long as the Corporation shall be obligated to pay any bonds, notes, or other obligations, and the Corporation, in such circumstances, shall remain valid and in effect in accordance with its terms.

B. No action shall be taken pursuant to Paragraph A of this Article, in any manner or at any time that would impair any contract, lease, right, or other obligation theretofore executed, granted, or incurred by the Corporation.

ARTICLE XX

The Corporation may indemnify any director, officer, agent or former director, officer or agent of the Corporation for expenses and costs, including attorney's fees, actually or necessarily incurred by the person in connection with any claim asserted against the person, by action in court or other forum, by reason of such person having been a director, officer or other agent.

ARTICLE XXI

These Articles of Incorporation may not be changed or amended unless approved by the City Council.

* * *

IN WITNESS WHEREOF, I have hereunto set our hands this 23rd day of April 2018.

CVJ

Incorporator-Chris Voulgaris

Tonya Machann

Incorporator-Tonya Machann

D Voulgaris

Incorporator-David Voulgaris

State of Texas §

County of Wharton §

Sworn to and subscribed before me on the 23rd day of April 2018 by Chris Voulgaris, Tonya Machann, and David Voulgaris respectively.



Brandi N. Jimenez

Notary Public

**CITY OF WHARTON
RESOLUTION NO. 2022-XX**

A RESOLUTION OF THE WHARTON CITY COUNCIL APPROVING THE DISSOLUTION OF THE CITY OF WHARTON HOUSING FINANCE CORPORATION; AUTHORIZING THE PREPARATION AND EXECUTION OF ALL DOCUMENTS NECESSARY TO DISSOLVE THE CORPORATION; AND AUTHORIZING THE MAYOR OF THE CITY OF WHARTON TO EXECUTE ALL DOCUMENTS RELATED TO THE DISSOLUTION.

WHEREAS, The Wharton City Council no longer sees a need for a City of Wharton Housing Finance Corporation in the City of Wharton; and,

WHEREAS, The Wharton City Council wishes to dissolve the City of Wharton Housing Finance Corporation as written in the Article of Incorporation; and,

WHEREAS, The Wharton City Council wishes to authorize the City Staff to prepare all documents necessary to effectively terminate the Corporation, including, but not limited to a certificate of termination; and,

NOW, THEREFORE, BE IT RESOLVED BY THE CITY COUNCIL OF THE CITY OF WHARTON, TEXAS as follows:

Section I. That the Wharton City Council hereby dissolves the City of Wharton Housing Finance Corporation.

Section II. The Wharton City Council hereby authorizes the City Staff to prepare all documents necessary to effectively terminate the Corporation, including, but not limited to a certificate of termination.

Section III. All assets, if any, of the Corporation shall be distributed to the City of Wharton, Texas.

Section IV. The Wharton City Council authorizes the Mayor of the City of Wharton to execute all documents related to the dissolution of the Corporation.

Section X. That this resolution shall become effective immediately upon its passage.

Passed, Approved, and Adopted this 27th day of June 2022.

CITY OF WHARTON, TEXAS

By: _____
TIM BARKER
Mayor

Attest: _____
PAULA FAVORS
City Secretary

City of Wharton
 120 E. Caney Street
 Wharton, TX 77488

CITY COUNCIL COMMUNICATION

Meeting Date:	6/27/2022	Agenda Item:	Update of City of Wharton Grant Programs.
<p>Attached is a copy of a memorandum from Director of Planning & Development, Gwyn Teves, providing an update on the City of Wharton Grant Programs.</p>			
City Manager: Joseph R. Pace		Date: Thursday, June 23, 2022	
Approval: 			
Mayor: Tim Barker			



MEMORANDUM

Date: June 22, 2022
From: Gwyneth Teves, Director of Planning & Development
To: Honorable Mayor and City Councilmembers
Paul Webb, City Attorney
Subject: Status of City of Wharton Grant Projects Report No. 2022-06

Below, I have outlined a report on the status of the City of Wharton Grant Projects:

I. GRANT PROJECTS

Infrastructure/Construction :

1. 2021 TxCDBG DRP/MS – Downtown Sidewalk Improvements

City staff in conjunction with GrantWorks, Inc. and KSA Engineering submitted an application of up to \$350,000 for downtown sidewalk renovations/additions. Contract execution with Texas Department of Agriculture (TDA) has been completed and pending project kick off meeting.

2. Santa Fe Channel Outfall Improvements

City staff has been working with USACE for emergency repairs and funding to make repairs to the outfall channel. **Construction to begin week of June 27th.**

3. CDBG-DR – Infrastructure

Method of Distribution approved by GLO and HUD. City has received an award of \$1,650,172.00 for infrastructure projects related to Hurricane Harvey. Jones & Carter has completed surveys and staff is currently working on easement acquisition and project budget. Staff is currently submitting a 2-year project extension request and is working with GrantWorks to complete an environmental delineation study and environmental clearance to proceed with acquisition and construction.

4. 2019-2020 CDBG – South East Ave. Sanitary Sewer Repairs

City has received funding and has finalized agreement and completed kick-off meeting with Tx Dept. of Agriculture. Project has been awarded and contractors mobilizing late May.

5. City of Wharton Flood Reduction Project – The Lower Colorado River Basin Phase I, Texas WHARTON FLOOD RISK MANAGEMENT PROJECT

The City of Wharton was notified that the Flood Reduction Project was funded in the early part of 2018. HDR was selected by the City Council on 06/14/19 for acquisition services.

Phase 2 currently under design.

Acquisitions for Phase 1 have been completed.

Phase 1 construction has been awarded and demo and construction anticipated early August 2022. City utility relocations are finishing early July 2022.

6. TxDOT – Safe Routes to School

The City staff was notified of award for this project April 30, 2021. Kickoff meeting with TxDOT occurred June 29th. 100% design provided to TxDOT for review and property owners notified of the project. Project to be let for construction September 2022.

7. 2023 TWDB Clean Water State Revolving Fund (CWSRF) – Mayfair/Linwood Waterline Replacement

The City has a history of high water loss and frequent leaks/outages in a number of areas that still have old 2" waterlines. These lines are also too small to provide any fire protection or allow the City to place fire hydrants in these older subdivisions. After completion of planning, environmental, and design the City intends to replace the 2" steel waterlines with 8" PVC waterlines improving water quality, reducing leaks/outages, and providing fire protection. Project Information Form submitted March 3, 2022.

8. 2023 TWDB Drinking Water State Revolving Fund (DWSRF) - Waste Water Treatment Plant 1 (WWTP 1) Replacement & Rehabilitation

Replacement and rehabilitation of components of WWTP 1 that have exceeded design service life to avoid possible eventual contamination of the Colorado River. Project Information Form submitted March 3, 2022.

9. LCRA Community Development Partnership Program (CDPP)

Facility renovations of the Wharton Civic Center improving the space as a conference/lecture and event rental space that would be able to meet the needs of multiple group sizes. City staff was notified on October 5th, 2021 that the City was awarded \$50,000 in grant funds to complete the renovations to the Civic Center. Construction has started on the project and is progressing as scheduled.

Housing:

10. CDBG-DR – Buyouts/Acquisitions

Method of Distribution approved by GLO and HUD. City has received an award of \$1,693,784.00 for buyout/acquisition projects related to Hurricane Harvey. The guidelines have been approved by the GLO and no public comment was received during the required posting period. Intake meetings continue with property owners and GrantWorks. Acquisition is under process with HDR, who was selected by City Council.

11. 2016 CDBG-DR – Housing Elevation/Reconstruction

Notification of \$2,000,000 funding was received February 4, 2019. 3 applications have been approved and are in home build selection phase. City issued notice of grant in utility billing, resulting in 12 new inquiries and a new total of 5 applicants, with 2 overall program applicant withdrawals. Construction completed on 2 homes May 2021 with 1 to begin December 2021. City staff received a 1-year extension on the

funding in order to complete construction and allow any additional possible applications to expend the funds. At the close of the last application period, 50 new applications were received. 23 were not in the city limits or not qualified due to income or flood status. 18 are still being processed and 9 have been completed and submitted for approval by the GLO.

Disaster Recovery (non-infrastructure or housing):

12. HMGP – Critical Facility Generators

The City received notification of award by TDEM 02/18/2020. Kick-off meeting conducted with TEDM on August 6th, 2020. **Preconstruction meeting to be held early July.**

13. 2021 American Rescue Plan - Coronavirus State and Local Fiscal Recovery Funds

Local governments will receive funds in two tranches, with 50% provided beginning in May 2021 and the balance delivered approximately 12 months later. States that have experienced a net increase in the unemployment rate of more than 2 percentage points from February 2020 to the latest available data as of the date of certification will receive their full allocation of funds in a single payment; other states will receive funds in two equal tranches. Governments of U.S. territories will receive a single payment. Tribal governments will receive two payments, with the first payment available in May and the second payment, based on employment data, to be delivered in June 2021. Public Management was contracted to administer the funds and required reporting.

II. STUDIES:

14. TWDB – Internal Drainage Study and Drainage Improvements

Application submitted under the TWDB Flood Infrastructure Fund to study flood risks inside the City Limits and ETJ and move forward with the most critical projects in Phase 1. The application is being reviewed by TWDB and one RFI has been completed. The project was approved by TWDB on July 7th, 2021, for funding. City Council has procured Langford Community Management Services for Administration and Jones & Carter Engineering to complete the project. A kickoff meeting was held on March 10, 2022.

III. OTHER PROJECTS & EVENTS:

15. FM 1301 Extension

All parcels have been acquired and City staff is currently working with the City attorney to voluntarily annex the property. City staff is also working with TxDOT to coordinate the transfer of ROW and construction of the roadway. Utilities are currently being relocated to make the ROW clear for construction letting anticipated to be performed in **October 2022.**

City of Wharton
120 E. Caney Street
Wharton, TX 77488

CITY COUNCIL COMMUNICATION

Meeting Date:	6/27/2022	Agenda Item:	Update of City of Wharton on-going Projects.
<p>Attached is a copy of my memorandum providing an update on the City of Wharton current projects as of May 31, 2022.</p>			
City Manager: Joseph R. Pace		Date: Thursday, June 23, 2022	
Approval: 			
Mayor: Tim Barker			



City of Wharton

120 E. Caney Street ° Wharton, TX 77488
Phone (979) 532-2491 ° Fax (979) 532-0181

Item-16.

MEMORANDUM

Date: June 22, 2022
From: Joseph R. Pace, City Manager
To: Honorable Mayor and City Councilmembers
City Attorney, Paul Webb
Subject: Status of City of Wharton Projects
Report No. 2022-05

Below, I have outlined a report on the status of the City of Wharton Projects:

FLOOD REDUCTION (LEVEE) PROJECT:

The U.S. Army Corp of Engineers (USACE) Lower Colorado River Phase I Report - City of Wharton Flood Prevention Project and Recommended report is located at the Wharton County Library and the office of the City of Wharton City Secretary for viewing or the report may be viewed on line at <http://www.cityofwharton.com/information-a-notices/lcrb-feasibility-study>. The Project Participation Agreement (PPA) has been executed. The City has hired HDR for Right-of-Way Acquisition and Jones & Carter for City and private company utility relocations. The City has acquired all properties for the project. Utility relocations for City utilities is near completion and all private utilities have been relocated or abandoned. All asbestos abatement has been completed. Phase 1 construction award Completed May 27th and contract being finalized with the contractor. Demo and construction anticipated to start early August 2022.

DRAINAGE:

1. Stavena Addition Drainage Project.

The design and construction plans are complete. The project is one of the construction projects to be funded with the Texas Water Development Board (TWDB) Flood Infrastructure Fund Program for partial assistance.

2. Ahldag Ditch Improvement.

The project was approved by the City Council. The ditch improvements were proposed under the Texas General Land Office (GLO) Infrastructure Grant Program. The staff is currently working with an appraiser for ROW acquisition. The project is also listed as one of the construction projects to be funded with the Texas Water Development Board (TWDB) Flood Infrastructure Fund Program for partial assistance. Project has currently been delayed due to environmental concerns with USACE permitting for jurisdictional waters.

3. On-going Drainage and Maintenance Program.

The Public Works Department has continued working on cleaning residential drainage ditches that have experienced poor drainage.

4. Pecan Acres (Mahan, Kinkaid, Delmas) Drainage Project.

Installation of the drainage pipes was completed. The City Public Works Department will be

regrading ditches to improve the drainage in the area. The project is listed as one of the construction projects to be funded with the Texas Water Development Board (TWDB) Flood Infrastructure Fund Program for partial assistance.

WATER/SEWER IMPROVEMENTS:

1. On-going Water and Sewer Maintenance Program.

Water leaks and sewer failures are still being seen in the month of May.

2. Water Well and Water Plant Project – CR 222 (Halford).

Monthly progress meetings are being held. Well drilling complete and pump being installed and set in August pending delivery. Ground storage tank construction complete. Plant construction still in progress.

STREET IMPROVEMENTS:

1. FM 1301 Extension and Overpass Project Progress Report.

IDC Inc. has submitted to TxDOT Yoakum District Office all required plans for the project. ROW is in process of being turned over to TxDOT for construction letting in October 2022.

2. I-69 Project.

The City submitted the comments as approved by the City Council to TxDOT. TxDOT has informed the City that CivilCorp engineering has begun design and the City is involved in regular coordination meetings. City staff is coordinating with Jones & Carter Engineering on utility relocations of water and sewer lines along I-69 that will be impacted by the expansion.

3. NanYa Exit Ramp Project.

TxDOT has been coordinating with NanYa and JM Eagle on the exit design. As of last coordination meeting the ramp has been implemented in the design with a turn around under the FM 102 overpass to allow for easy access to the retail area on the alternate side of the Interstate.

City of Wharton
120 E. Caney Street
Wharton, TX 77488

CITY COUNCIL COMMUNICATION

Meeting Date:	6/27/2022	Agenda Item:	Appointments, Resignations and Vacancies to the City of Wharton Boards, Commissions and Committees: <ul style="list-style-type: none"> A. Appointments. B. Resignations. C. Vacancies.
<p>Attached you will find the list of persons serving on the various City Boards, Commissions and Committees. There are still vacancies that also need to be filled.</p> <p><u>Appointments:</u></p> <ol style="list-style-type: none"> 1. Wharton Regional Airport Board: Larry David, Jimmy Zissa and Glenn Erdelt (Re-Appointments). 2. Beautification Commission: Rachel Roberson (Re-Appointment) and Nancy Mata. 3. Building Standards Commission: Howard Singleton (Re-Appointment). 4. Electrical Board: Philip Hamlin and Milton Barbee (Re-Appointments). 5. Holiday Light Decorating Chairman: Mayor Tim Barker (Re-Appointment). 6. Mayor's Committee on People with Disabilities: Johnnie Gonzalez, Faye Evans and Rebekah Kirschke (Re-Appointments). 7. Health Officer: Dr. Jeff Gubbels (Re-Appointment). 8. Veterinarian: Dr. Cody Pohler (Re-Appointment). 9. Planning Commission: Adraylle Watson, Marshall Francis and Michael Wootton (Re-Appointments). 10. Plumbing and Mechanical Board: A.J. Rath (Re-Appointment). 11. Housing Finance Corporation: <p><u>Resignations:</u></p> <ol style="list-style-type: none"> 1. Beautification Commission : Tammie Janik and Debbie Newlin. <p><u>Vacancies:</u></p> <ol style="list-style-type: none"> 1. Beautification Commission: 1 vacancy. 2. Building Standards: 3 vacancies. 3. Planning Commission: 1 vacancy. 4. Plumbing and Mechanical Board: 2 vacancies. 			
City Manager: Joseph R. Pace		Date: Thursday, June 23, 2022	
Approval: 			
Mayor: Tim Barker			

**CITY OF WHARTON
BOARDS, COMMISSIONS AND COMMITTEES**

WHARTON REGIONAL AIRPORT BOARD	TWO YEAR TERM	Reappointment
Jimmy Gardner	June 30, 2023	
Randy Rodriguez	June 30, 2023	
Bill Kingrey	June 30, 2023	
Larry David	June 30, 2022	Yes
Jimmy Zissa	June 30, 2022	Yes
Glenn Erdelt	June 30, 2022	Yes

BEAUTIFICATION COMMISSION	TWO YEAR TERM	Reappointment
Tammie Janik	June 30, 2022	No
Debbie Newlin	June 30, 2022	No
Rachel Roberson	June 30, 2022	Yes
Stephanie Konvicka	June 30, 2023	
Adrayelle Watson	June 30, 2023	
Debbie Folks	June 30, 2023	
Kenneth Dimmick	June 30, 2023	

BUILDING STANDARDS COMMISSION	TWO YEAR TERM	Reappointment
Leonard Morales	June 30, 2023	
Burnell Neal	June 30, 2023	
Vacant	June 30, 2023	
Paul Shannon	June 30, 2023	
Vacant	June 30, 2022	
Howard Singleton	June 30, 2022	Yes
Vacant	June 30, 2022	
Ronnie Bollom, Building Official - ExOfficio		
Jeff Gubbels - Health Officer-ExOfficio		
Hector Hernandez-Fire Marshall-ExOfficio		

ELECTRICAL BOARD	TWO YEAR TERM	Reappointment
Councilmember Clifford Jackson	June 30, 2023	
Zac Henson	June 30, 2023	
Philip Hamlin	June 30, 2022	Yes
Milton Barbee	June 30, 2022	Yes
Hector Hernandez- Fire Marshal		

HOLIDAY LIGHT DECORATING CHAIRMAN	TWO YEAR TERM	Reappointment
Tim Barker	June 30, 2022	Yes

MAYOR'S COMMITTEE ON PEOPLE WITH DISABILITIES	TWO YEAR TERM	Reappointment
Johnnie Gonzalez	June 30, 2022	Yes

Faye Evans	June 30, 2022	Yes
Rebekah Kirschke	June 30, 2022	Yes
Adraylle Watson	June 30, 2023	
Marilyn Sebesta	June 30, 2023	
Sandy Wilkins	June 30, 2023	
Cheryl Lavergne	June 30, 2023	
Mayor Tim Barker- Ex Officio		

HEALTH OFFICER	TWO YEAR TERM	Reappointment
Dr. Jeff Gubbels, MD	June 30, 2022	Yes

VETERINARIAN	TWO YEAR TERM	Reappointment
Dr. Cody Poler, DVM	June 30, 2022	Yes

MUNICIPAL COURT JUDGE	TWO YEAR TERM	Reappointment
Jared Cullar	June 30, 2023	

PLANNING COMMISSION	TWO YEAR TERM	Reappointment
Burnell Neal	June 30, 2023	
Rob Kolacny	June 30, 2023	
Michael Quinn	June 30, 2023	
Marshall Francis	June 30, 2022	Yes
Adraylle Watson	June 30, 2022	Yes
Michael Wootton	June 30, 2022	Yes
Russell Cenko	June 30, 2022	No

PLUMBING AND MECHANICAL BOARD	TWO YEAR TERM	Reappointment
A. J. Rath	June 30, 2022	Yes
Tom Faust	June 30, 2023	
Vacant	June 30, 2022	
Robert Sanchez	June 30, 2023	
Vacant	June 30, 2022	

Ronnie Bollom, Building Official - ExOfficio
Public Works Director Anthony Arcidiacono- Ex Officio
Mayor Tim Barker - Ex Officio

WHARTON ECONOMIC DEVELOPMENT CORPORATION	TWO YEAR TERM	Reappointment
Michael Wootton	September 30, 2022	
David Schroeder	September 30, 2022	
Freddie Pekar	September 30, 2022	
Clifford Jackson (Councilmember)	September 30, 2022	
Russell Machann- (Councilmember)	September 30, 2023	
Andrew Armour	September 30, 2023	
Michael Roberson	September 30, 2023	

HOUSING FINANCE CORPORATION	TWO YEAR TERM	Reappointment
Position 1 District 1-Curtis Edwards	June 30, 2023	
Position 2 District 2-Worthy Carpenter	June 30, 2022	
Position 3 District 3-Morris Dean	June 30, 2023	
Position 4 District 4-Vacant	June 30, 2022	
Position 5 District 5-At Large-Gary Nunez	June 30, 2023	
Position 6 District 6-At Large-Tonya Machann	June 30, 2022	
Position 7 Mayor-At Large-Morrow Lou Sims	June 30, 2022	

CITY COUNCIL COMMITTEES - Renew June 30th of Each Year

ANNEXATION COMMITTEE

Tim Barker
 Russell Machann
 Don Mueller

FINANCE COMMITTEE

Russell Machann
 Larry Pittman
 Tim Barker

HOUSING COMMITTEE

Terry Freese
 Russell Machann
 Clifford Jackson

INTERGOVERNMENTAL RELATIONS COMMITTEE

Terry Freese
 Tim Barker
 Larry Pittman

LEGISLATIVE COMMITTEE

Tim Barker
 Larry Pittman
 Steven Schneider

PUBLIC HEALTH COMMITTEE

Terry Freese
 Larry Pittman
 Russell Machann

PUBLIC SAFETY COMMITTEE

Larry Pittman
 Terry Freese
 Don Mueller

PUBLIC WORKS COMMITTEE

Terry Freese
 Don Mueller
 Clifford Jackson

TELECOMMUNICATIONS COMMITTEE

Clifford Jackson
 Terry Freese
 Don Mueller

WHARTON ECONOMIC DEVELOPMENT CORP BOARD OF DIRECTORS SELECTION COMMITTEE

Tim Barker
 Steven Schneider
 Clifford Jackson

ECONOMIC DEVELOPMENT COMMITTEE

Tim Barker
 Clifford Jackson
 Russell Machann

PARKS AND RECREATION COMMITTEE

Steven Schneider
 Russell Machann
 Terry Freese



City of Wharton

120 E. Caney Street ° Wharton, TX 77488
Phone (979) 532-2491° Fax (979) 532-0181

MEMORANDUM

Date: 6/14/2022

From: Dwayne Pospisil, Airport

To: Joseph R. Pace, City Manager

Subject: Airport Board Members renew

The following airport board members will be renewing their terms.

Larry David

Jimmy Zissa

Glenn Erdelt



City of Wharton

120 E. Caney • Wharton, TX 77488
Phone (979) 532-2491 • Fax (979) 532-0181

MEMORANDUM

DATE: June 7, 2022
FROM: Krystal Hasselmeier, Planning & Development Specialist
TO: Honorable Mayor and City Council
SUBJECT: Beautification Commission Membership

Beautification Commission currently has two expiring terms. The two members with expiring terms are relinquishing their seats. One new request for consideration of appoint to the Beautification Commission has been received at this time.

Expiring Positions:

Tammie Janik
Deborah Newlin
Rachel Roberson

Renewal Request(s):

Rachel Roberson

New Request(s):

Nancy Mata

If you should have any questions, please contact me at 979-532-2491 ext. 239. Thank You.

From: Deborah Newlin <debkn2023@gmail.com>
Sent: Monday, February 14, 2022 10:43 AM
To: khasselmeier@cityofwharton.com
Subject: Position on Committee

Good Morning Krystal,

With this email I want you to know that I will not be requesting renewal for my seat on the committee. I am retiring this year as you know and I have many personal projects coming up. I will not be able to give 100% to this board and that is what is needed.

I am sending this now since I know there are others interested in the position.

Thank you Krystal for all you do!! This board/committee would be hopelessly lost without your knowledge and input.

Debbie
Cell 979.533.2058

From: Tammie Janik <tammie.janik@gmail.com>
Sent: Wednesday, February 23, 2022 3:36 PM
To: khasselmeier@cityofwharton.com
Subject: Re: Packet Submission Reminder

Hello!

Let this be notification that I would like to rotate off the commission in June.

Thanks,
Tammie

khasselmeier@cityofwharton.com

From: Nancy Mata <ngm7772@gmail.com>
Sent: Monday, May 16, 2022 7:06 PM
To: Khasselmeier@cityofwharton.com
Subject: WBC Applicant

Krystal,

My name is Nancy Mata, I have been employed with WISD for 24 years as a teacher at Sivells Elementary School. For the past month, I have been involved with the Wharton Beautifcan Committee, helping with their booth at Farmers Market and their annual seed shaker event. I am a long time citizen at Wharton and will remain, and would love for the opportunity to be part of the commission. I care about my community deeply and want to serve and help keep Wharton Beautiful!

Thank you in advance for your time and consideration.

Nancy Mata
519 S Caney Dr, Wharton, TX 77488
9792577697



City of Wharton

120 E. Caney Street ° Wharton, TX 77488
Phone (979) 532-2491° Fax (979) 532-0181

MEMORANDUM

Date: June 7, 2022
From: Jimmy F. Nickolyn
To: Brandi Jimenez
Subject: Building Standard Commission Members

As of today, there are only three members on the City of Wharton Building Standards Commission. They are Howard Singleton (Vice Chairman) whose term comes due on June 22, 2022, and on May 11, 2022, he requested that he **wanted to remain** on the Building Standards Commission. The other two members are, Mr. Leonard Morales; his term on the Building Standards Commission does not end until June 30, 2023 and Mr. Paul Shannon whose term also doesn't end until June 30, 2023

The other remaining members, Chester Houston (Chairman), Damon Parker (Secretary), and Shaun Stockwell, all now reside outside of Wharton city limits which make the ineligible to remain on the City of Wharton Building Standards Commission. Mr. I.O. Coleman, who was on the Building Standards Commission passed away this year therefore leaving at the moment only two (3) viable commission members.



City of Wharton
120 E. Caney Street ° Wharton, TX 77488
Phone (979) 532-2491 °(979) 532-0181 FAX

Date: June 9, 2022
From: Claudia Velasquez, Building Official Assistant
To: Electrical Board
Subject: Renewal of Term

Board Member Philip Hamlin has expressed a willingness to renew his term on the Electrical Board effective June 30, 2022.

If you have any questions, please contact me at City Hall (979) 532-4811, Ext. 232.



City of Wharton
120 E. Caney Street ° Wharton, TX 77488
Phone (979) 532-2491 °(979) 532-0181 FAX

Date: June 9, 2022
From: Claudia Velasquez, Building Official Assistant
To: Electrical Board
Subject: Renewal of Term

Board Member Milton Barbee has expressed a willingness to renew his term on the Electrical Board effective June 30, 2022.

If you have any questions, please contact me at City Hall (979) 532-4811, Ext. 232.



City of Wharton
120 E. Caney Street ° Wharton, TX 77488
Phone (979) 532-2491 °(979) 532-0181 FAX

Date: May 11, 2022
From: Claudia Velasquez, Building Official Assistant
To: Mayor's Committee on People with Disabilities
Subject: Renewal of Term

Committee Member Johnny Gonzales has expressed a willingness to renew his term on the Mayor's Committee on People with Disabilities effective June 30, 2022.

If you have any questions, please contact me at City Hall (979) 532-4811, Ext. 232.



City of Wharton
120 E. Caney Street ° Wharton, TX 77488
Phone (979) 532-2491 °(979) 532-0181 FAX

Date: May 11, 2022
From: Claudia Velasquez, Building Official Assistant
To: Mayor's Committee on People with Disabilities
Subject: Renewal of Term

Committee Member Faye Evans has expressed a willingness to renew her term on the Mayor's Committee on People with Disabilities effective June 30, 2022.

If you have any questions, please contact me at City Hall (979) 532-4811, Ext. 232.



City of Wharton
120 E. Caney Street ° Wharton, TX 77488
Phone (979) 532-2491 °(979) 532-0181 FAX

Date: May 16, 2022
From: Claudia Velasquez, Building Official Assistant
To: Mayor's Committee on People with Disabilities
Subject: Renewal of Term

Committee Member Rebekah Kirschke has expressed a willingness to renew her term on the Mayor's Committee on People with Disabilities effective June 30, 2022.

If you have any questions, please contact me at City Hall (979) 532-4811, Ext. 232.

City of Wharton
 120 E. Caney Street
 Wharton, TX 77488

CITY COUNCIL COMMUNICATION

Meeting Date:	6/27/2022	Agenda Item:	City Council Boards, Commissions and Committee Reports: A. Finance Committee meeting held June 13, 2022.
Attached you will find the reports from the above-mentioned Committees.			
City Manager: Joseph R. Pace		Date: Thursday, June 23, 2022	
Approval: 			
Mayor: Tim Barker			



City of Wharton

120 E. Caney Street ° Wharton, TX
77488

Phone (979) 532-2491° Fax (979) 532-
0181

MEMORANDUM

Date: June 14, 2022

From: City Council Finance Committee

To: Mayor & City Council

Subject: Report/Recommendations from the meeting held June 13, 2022

At the June 13, 2022, City Council Finance Committee Meeting, the Committee met and discussed the following items:

1. Review & Consider: Minutes from the meeting held May 16, 2022.
2. Review & Consider: Resolution: A resolution of the Wharton City Council approving the Interlocal Agreement with the Texas Municipal League Health Benefits Pool (TML Health Benefits Pool) for medical, long-term disability, life, accidental death & dismemberment, for flexible spending account, health reimbursement account and voluntary vision plans for City employees for the October 1, 2022 to September 30, 2023 Fiscal Year; and Sun Life Financial for voluntary dental coverage for City employees; authorizing the Mayor of the City of Wharton to execute all documents relating to said contracts. The Committee voted to recommend this item to the City Council for consideration.
3. Review & Consider: Request for Privileged Liens Amnesty. The Committee voted to recommend this item to the City Council for consideration.

Adjournment.

City of Wharton
 120 E. Caney Street
 Wharton, TX 77488

CITY COUNCIL COMMUNICATION

Meeting Date:	6/27/2022	Agenda Item:	City Manager’s Reports: A. City Secretary/Personnel. B. Code Enforcement. C. Community Services Department/Civic Center. D. Emergency Management. E. E. M. S. Department. F. Facilities Maintenance Department/Wharton Municipal Pool. G. Fire Department. H. Fire Marshal. I. Legal Department. J. Municipal Court. K. Police Department. L. Public Works Department. M. Water/Sewer Department. N. Weedy Lots/Sign Ordinance. O. Wharton Regional Airport.
City Manager: Joseph R. Pace		Date: Thursday, June 23, 2022	
Approval: 			
Mayor: Tim Barker			



City of Wharton
120 E. Caney Street ° Wharton, TX 77488
Phone (979) 532-2491° Fax (979) 532-0181

MEMORANDUM

Date: June 7, 2022
From: Paula Favors, TRMC, City Secretary
To: Joseph R. Pace, City Manager
Subject: May 2022 Monthly Personnel Report

HIRED

There were not any new hires in the month of May 2022.

PROMOTION

There were not any promotions in the month of May 2022.

TERMINATION

Brandon McNeal separated from employment in the month of May 2022.
Tamara Lee Meyen separated from employment in the month of May 2022.

INCREASE IN WAGES

There were not any increases in wages in the month of May 2022.

If you have any questions, please contact me at City Hall. Thank you.



City of Wharton
120 E. Caney Street ° Wharton, TX 77488
Phone (979) 532-2491 °(979) 532-0181 FAX

Date: June 2, 2022
From: Ronnie Bollom, Building Official
To: Joseph Pace, City Manager
Subject: Permit Report for May 2022

Please see the following for your review; Project Valuation and Fee Report from the Permitting/Code Enforcement Department for the month of May 2022.

If you should have any questions, please contact me at City Hall at 979-532-2491. Thank you.

PROJECTS: 0 -ZZZZZZZZZZ

APPLIED DATES: 5/01/2022 THRU 5/31/2022

ISSUED DATES: 0/00/0000 THRU 99/99/9999 USE SEGMENT DATES

EXPIRE DATES: 0/00/0000 THRU 99/99/9999

STATUS: ALL

Item-19.

PROJECT SEGMENT	ISSUE DATE SEGMENT DT	NAME DESCRIPTION	LOCATION BUILDING CODE	CONTRACTOR SEG. CONT.	DESCRIPTION VALUATION	PROJ TYPE FEE
2200430 BPC	5/02/2022 5/02/2022	DOBBINS & SHEEK BUILDING COMM. PERMIT	300 W BURLESON 331 - CONCRETE APPLICATIONS	BTOTAL BTOTAL	8X4 CONCRETE RAMP 800.00	BPC 30.00
2200431 BLD-ER	5/02/2022 5/02/2022	RAYBON, GARY BUILDING (E) RESIDENTIAL	1520 KELVING WAY 300 - BUILDING-ELECTRICAL	EBARBEE EBARBEE	REPLACE DAMAGED METER CAN 0.00	BLD-ER 35.00
2200432 PLB	5/02/2022 5/02/2022	CENSEO HOMES PLUMBING PERMIT	803 N SPANISH CAMP 900 - PLUMBING PERMITS	PKAISER PKAISER	AE:NEW PLUMBING FOR RESID. 6,800.00	PLB 95.00
2200433 MOW	5/02/2022 5/02/2022	BATAINEH, AUTUMN M MOWING	101 KELLY	OWNER OWNER	WEEDY LOT 0.00	MOW 0.00
2200434 MEC	5/03/2022 5/03/2022	HOUSE, W S MECHANICAL PERMIT	1625 KELVING WAY 800 - MECHANICAL PERMITS	MROBERSON MROBERSON	5TON 14 SEER AC-NO DUCT 9,670.00	MEC 100.00
2200435 PLB	5/03/2022 5/03/2022	BURKE'S OUTLET STORES PLUMBING PERMIT	301 E BOLING HWY 900 - PLUMBING PERMITS	PHACKETT PHACKETT	INTERIOR PLUMBING REMODEL 0.00	PLB 80.00
2200436 BPR	5/04/2022 5/04/2022	STAVENA, LAMBERT BUILDING RESID. PERMIT	2320 OLD LANE CITY 439 - ROOFING	BEDI HERR BEDI HERR	REROOF W/COMP. SHINGLES 0.00	BPR 47.50
2200437 PLNC	5/04/2022 5/04/2022	BAIRD, RUSSELL PLAN REVIEW COMMERCIAL	102 N POLK PLAN - PLAN REVIEW	BACCESS CO BACCESS CO	REAR BALCONY + STAIRS 23,000.00	PLNREV 46.00
2200438 MEC	5/04/2022 5/04/2022	CERVANTES, EMILIO MECHANICAL PERMIT	604 MAPLE 800 - MECHANICAL PERMITS	MTAYLORM MTAYLORM	AE:3TON COND, GAS FURN.+DUC 5,800.00	MEC 80.00
2200439 BPR	5/05/2022 5/05/2022	JUSTICE, BRENDA BUILDING RESID. PERMIT	325 N RICHMOND 439 - ROOFING	BROCKY G BROCKY G	REROOF WITH 27 SQ OF 25 YR 0.00	BPR 67.50
2200440 DEM	5/05/2022 5/05/2022	BAIRD, RUSSELL DEMOLITIONS PERMIT	313 W MILAM 600 - DEMOLITIONS AND RAZIN	BSAM CORTE BSAM CORTE	DEMOLITION INTERIOR 27' OF 1,200.00	DEM 50.00
2200441 BPR	5/05/2022 5/05/2022	CRUZ, JOHNNY BUILDING RESID. PERMIT	400 AVENUE C 442 - NONRESIDENTIAL ACCESS	BGENERAL BGENERAL	24' X 40' METAL CARPORT 0.00	BPR 160.00
2200442 BPC	5/05/2022 5/05/2022	DUECK, EUGENE BUILDING COMM. PERMIT	1506 N ALABAMA C 435A - COMMERCIAL REMODELS	BJOSE EST BJOSE EST	12X40' WALL DIVIDER 8,900.00	BPC 86.00
2200443 BPR	5/05/2022 5/05/2022	CLEMENTS, RICHARD BUILDING RESID. PERMIT	621 N RUSK 439 - ROOFING	BDC CONST BDC CONST	REMOVE/REPLACE ROOF 0.00	BPR 110.00
2200444 BLD-EC	5/06/2022 5/06/2022	HOBBS, HALEY BUILDING (E) COMMERCIAL	129 S FULTON 300 - BUILDING-ELECTRICAL	EGULF EGULF	INTERIOR ELECTRICAL REMODEL 25,000.00	BLD-EC 198.00
2200445 BLD-ER	5/05/2022 5/05/2022	BSR CONSTRUCTION LLC BUILDING (E) RESIDENTIAL	1432 LA DELLE 300 - BUILDING-ELECTRICAL	ELANDMARK ELANDMARK	NEW ELECT. FOR RESID. 7,950.00	BLD-ER 175.00

PROJECTS: 0 -ZZZZZZZZZZ

APPLIED DATES: 5/01/2022 THRU 5/31/2022

ISSUED DATES: 0/00/0000 THRU 99/99/9999 USE SEGMENT DATES

EXPIRE DATES: 0/00/0000 THRU 99/99/9999

STATUS: ALL

Item-19.

PROJECT SEGMENT	ISSUE DATE SEGMENT DT	NAME DESCRIPTION	LOCATION BUILDING CODE	CONTRACTOR SEG. CONT.	DESCRIPTION VALUATION	PROJ TYPE FEE
2200446 MEC	5/04/2022 5/04/2022	BSR CONSTRUCTION LLC MECHANICAL PERMIT	1512 LA DELLE 800 - MECHANICAL PERMITS	MLUCKS MLUCKS	2.5TON HVAC SYSTEM + DUCT 8,850.00	MEC 95.00
2200447 MEC	5/04/2022 5/04/2022	BSR CONSTRUCTION LLC MECHANICAL PERMIT	1510 LA DELLE 800 - MECHANICAL PERMITS	MLUCKS MLUCKS	2.5TON HVAC SYSTEM + DUCT 8,850.00	MEC 95.00
2200448 MEC	5/04/2022 5/04/2022	BSR CONSTRUCTION LLC MECHANICAL PERMIT	1508 LA DELLE 800 - MECHANICAL PERMITS	MLUCKS MLUCKS	2.5TON HVAC SYSTEM + DUCT 8,850.00	MEC 95.00
2200449 MEC	5/04/2022 5/04/2022	BSR CONSTRUCTION LLC MECHANICAL PERMIT	1506 LA DELLE 800 - MECHANICAL PERMITS	MLUCKS OWNER	2.5TON HVAC SYSTEM + DUCT 8,850.00	MEC 95.00
2200450 MEC	5/04/2022 5/04/2022	BSR CONSTRUCTION LLC MECHANICAL PERMIT	1436 LA DELLE 800 - MECHANICAL PERMITS	MLUCKS MLUCKS	2.5TON HVAC SYSTEM + DUCT 8,850.00	MEC 95.00
2200451 MEC	5/04/2022 5/04/2022	BSR CONSTRUCTION LLC MECHANICAL PERMIT	1432 LA DELLE 800 - MECHANICAL PERMITS	MLUCKS MLUCKS	2.5TON HVAC SYSTEM + DUCT 8,850.00	MEC 95.00
2200452 MEC	5/04/2022 5/04/2022	BSR CONSTRUCTION LLC MECHANICAL PERMIT	1430 LA DELLE 800 - MECHANICAL PERMITS	MLUCKS MLUCKS	2.5TON HVAC SYSTEM + DUCT 8,850.00	MEC 95.00
2200453 MEC	5/04/2022 5/04/2022	BSR CONSTRUCTION LLC MECHANICAL PERMIT	1428 LA DELLE 800 - MECHANICAL PERMITS	MLUCKS MLUCKS	2.5TON HVAC SYSTEM + DUCT 8,850.00	MEC 95.00
2200454 MEC	5/04/2022 5/04/2022	BSR CONSTRUCTION LLC MECHANICAL PERMIT	1426 LA DELLE 800 - MECHANICAL PERMITS	MLUCKS MLUCKS	2.5TON HVAC SYSTEM + DUCT 8,850.00	MEC 95.00
2200455 MEC	5/04/2022 5/04/2022	BSR CONSTRUCTION LLC MECHANICAL PERMIT	1513 LA DELLE 800 - MECHANICAL PERMITS	MLUCKS MLUCKS	2.5TON HVAC SYSTEM + DUCT 8,850.00	MEC 95.00
2200456 MEC	5/04/2022 5/04/2022	BSR CONSTRUCTION LLC MECHANICAL PERMIT	1511 LA DELLE 800 - MECHANICAL PERMITS	MLUCKS MLUCKS	2.5TON HVAC SYSTEM + DUCT 8,850.00	MEC 95.00
2200457 MEC	5/04/2022 5/04/2022	BSR CONSTRUCTION LLC MECHANICAL PERMIT	1509 LA DELLE 800 - MECHANICAL PERMITS	MLUCKS MLUCKS	2.5TON HVAC SYSTEM + DUCT 8,850.00	MEC 95.00
2200458 MEC	5/04/2022 5/04/2022	BSR CONSTRUCTION LLC MECHANICAL PERMIT	1507 LA DELLE 800 - MECHANICAL PERMITS	MLUCKS MLUCKS	2.5TON HVAC SYSTEM + DUCT 8,850.00	MEC 95.00
2200459 MEC	5/04/2022 5/04/2022	BSR CONSTRUCTION LLC MECHANICAL PERMIT	1437 LA DELLE 800 - MECHANICAL PERMITS	MLUCKS MLUCKS	2.5TON HVAC SYSTEM + DUCT 8,850.00	MEC 95.00
2200460 MEC	5/04/2022 5/04/2022	BSR CONSTRUCTION LLC MECHANICAL PERMIT	1433 LA DELLE 800 - MECHANICAL PERMITS	MLUCKS MLUCKS	2.5TON HVAC SYSTEM + DUCT 8,850.00	MEC 95.00
2200461 MEC	5/04/2022 5/04/2022	BSR CONSTRUCTION LLC MECHANICAL PERMIT	1431 LA DELLE 800 - MECHANICAL PERMITS	MLUCKS MLUCKS	2.5TON HVAC SYSTEM + DUCT 8,850.00	MEC 95.00

PROJECTS: 0 -ZZZZZZZZZZ

APPLIED DATES: 5/01/2022 THRU 5/31/2022

ISSUED DATES: 0/00/0000 THRU 99/99/9999 USE SEGMENT DATES

EXPIRE DATES: 0/00/0000 THRU 99/99/9999

STATUS: ALL

Item-19.

PROJECT SEGMENT	ISSUE DATE SEGMENT DT	NAME DESCRIPTION	LOCATION BUILDING CODE	CONTRACTOR SEG. CONT.	DESCRIPTION VALUATION	PROJ TYPE FEE
2200462 MEC	5/04/2022 5/04/2022	BSR CONSTRUCTION LLC MECHANICAL PERMIT	1429 LA DELLE 800 - MECHANICAL PERMITS	MLUCKS MLUCKS	2.5TON HVAC SYSTEM + DUCT 8,850.00	MEC 95.00
2200463 MEC	5/04/2022 5/04/2022	BSR CONSTRUCTION LLC MECHANICAL PERMIT	1427 LA DELLE 800 - MECHANICAL PERMITS	MLUCKS MLUCKS	2.5TON HVAC SYSTEM + DUCT 8,850.00	MEC 95.00
2200464 PLB	5/09/2022 5/09/2022	PERRY, JUDD & LAUREN PLUMBING PERMIT	1212 PECAN 900 - PLUMBING PERMITS	PTIME PTIME	WATER LINE METER TO HOUSE 0.00	PLB 35.00
2200465 BPR	5/09/2022 5/09/2022	IRBY, MATTHEW BUILDING RESID. PERMIT	916 BREEZY LANE 436 - NONRESIDENTIAL ADDITI	BBW FENCE BBW FENCE	6FT PRIVACY WOOD FENCE 279. 0.00	BPR 97.83
2200466 PLNR	5/09/2022 5/09/2022	EXUMA CONSTRUCTION & DEV. L PLAN REVIEW RESIDENTIAL	119 N RESIDENT PLAN - PLAN REVIEW	OWNER OWNER	PLAN REVIEW 0.00	PLNREV 319.28
2200467 BPR	5/09/2022 5/09/2022	GOMEZ, ROXANE BUILDING RESID. PERMIT	331 CROOM 442 - NONRESIDENTIAL ACCESS	OWNER OWNER	12'X15' METAL CARPORT 0.00	BPR 50.00
2200468 PLB	5/05/2022 5/05/2022	VASQUEZ, ALBERTO PLUMBING PERMIT	532 E ELM 900 - PLUMBING PERMITS	PBRAZOS PBRAZOS	AE:NEW PLUMBING FOR RESID. 1,500.00	PLB 85.00
2200469 PLB	5/10/2022 5/10/2022	TAYLOR, SHEILA PLUMBING PERMIT	1224 KINGSTON 900 - PLUMBING PERMITS	POVERALL POVERALL	W/H 0.00	PLB 30.00
2200470 BPR	5/10/2022 5/10/2022	MOHR, BRUCE BUILDING RESID. PERMIT	1822 CHAPEL HEIGHTS 439 - ROOFING	BPRIORITYR BPRIORITYR	REROOF 30YR SHINGLES 20SQ 0.00	BPR 50.00
2200471 PLB	5/11/2022 5/11/2022	COCHRAN, JOHN PLUMBING PERMIT	1827 N RICHMOND 900 - PLUMBING PERMITS	PSEAMANPLU PSEAMANPLU	2 FIXTURES & WATER LN 0.00	PLB 45.00
2200472 MOW	5/11/2022 5/11/2022	GARCIA, ANGEL MOWING	1214 W MILAM	OWNER OWNER	WEEDY LOT 0.00	MOW 0.00
2200473 PLB	5/11/2022 5/11/2022	CERVANTES, EMILIO PLUMBING PERMIT	604 MAPLE 900 - PLUMBING PERMITS	PSPEEDWAY PSPEEDWAY	AE:NEW PLUMBING FOR RESID 0.00	PLB 105.00
2200474 BLD-EC	5/11/2022 5/11/2022	HARRISON BROTHERS PROPERTIE BUILDING (E) COMMERCIAL	200 W MILAM 300 - BUILDING-ELECTRICAL	EBARBEE EBARBEE	3-PHASE PANEL FOR BUILDING 3,000.00	BLD-EC 44.00
2200475 PLB	5/10/2022 5/10/2022	BSR CONSTRUCTION LLC PLUMBING PERMIT	1427 LA DELLE 900 - PLUMBING PERMITS	PKAISER PKAISER	NEW PLUMBING FOR RESID. 6,800.00	PLB 100.00
2200476 PLB	5/10/2022 5/10/2022	BSR CONSTRUCTION LLC PLUMBING PERMIT	1429 LA DELLE 900 - PLUMBING PERMITS	PKAISER PKAISER	NEW PLUMBING FOR RESID. 6,800.00	PLB 100.00
2200477 PLB	5/10/2022 5/10/2022	BSR CONSTRUCTION LLC PLUMBING PERMIT	1426 LA DELLE 900 - PLUMBING PERMITS	PKAISER PKAISER	NEW PLUMBING FOR RESID. 6,800.00	PLB 100.00

PROJECTS: 0 -ZZZZZZZZZZ

APPLIED DATES: 5/01/2022 THRU 5/31/2022

ISSUED DATES: 0/00/0000 THRU 99/99/9999 USE SEGMENT DATES

EXPIRE DATES: 0/00/0000 THRU 99/99/9999

STATUS: ALL

Item-19.

PROJECT SEGMENT	ISSUE DATE SEGMENT DT	NAME DESCRIPTION	LOCATION BUILDING CODE	CONTRACTOR SEG. CONT.	DESCRIPTION VALUATION	PROJ TYPE FEE
2200478 PLB	5/10/2022 5/10/2022	BSR CONSTRUCTION LLC PLUMBING PERMIT	1428 LA DELLE 900 - PLUMBING PERMITS	PKAISER PKAISER	NEW PLUMBING FOR RESID. 6,800.00	PLB 100.00
2200479 BPR	5/11/2022 5/11/2022	28 PALM DEVELOPMENT GROUP BUILDING RESID. PERMIT	2404 N FULTON 435 - RESIDENTIAL REMODELS	BUCASA BUCASA	AE:REMODEL + 432SQFT ADDITI 0.00	BPR 466.54
2200480 DEV	5/11/2022 5/11/2022	28 PALM DEVELOPMENT GROUP DEVELOPMENT PERMIT	2404 N FULTON DEV - DEVELOPMENT PERMIT	BUCASA BUCASA	REMODEL + 432SQFT ADDITION 0.00	DEV 50.00
2200481 PLB	5/12/2022 5/12/2022	SODERSTROM, DOUG PLUMBING PERMIT	1212 BRIAR LANE 900 - PLUMBING PERMITS	PMASON PMASON	GAS TEST 0.00	PLB 35.00
2200482 MOW	5/12/2022 5/12/2022	LANDTRUST USA INC MOWING	000.1 S SHEPPARD	OWNER OWNER	WEEDY LOT 0.00	MOW 0.00
2200485 BLD-EC	5/16/2022 5/16/2022	WHARTON ISD - HIGH SCHOOL G BUILDING (E) COMMERCIAL	1 TIGER AVENUE 300 - BUILDING-ELECTRICAL	EPENNER EPENNER	GYM: ELECTRICAL LIGHTS/AC O 115,000.00	BLD-EC 764.00
2200486 BLD-EC	5/16/2022 5/16/2022	WCJC PEACE BUILDING BUILDING (E) COMMERCIAL	911 E BOLING HWY 9-PEA 300 - BUILDING-ELECTRICAL	EBARBEE EBARBEE	LIGHTS & EXIT SIGNS 21,611.00	BLD-EC 174.28
2200487 BPC	5/16/2022 5/16/2022	ST THOMAS EPISCOPAL CHURCH BUILDING COMM. PERMIT	207 BOB O LINK 435A - COMMERCIAL REMODELS	BSTOCKWELL BSTOCKWELL	EXTERIOR:FASCIA/SIDING/DOOR 13,000.00	BPC 114.00
2200488 BPR	5/16/2022 5/16/2022	CERRILLO, SUSAN BUILDING RESID. PERMIT	422 MOCKINGBIRD LANE 331 - CONCRETE APPLICATIONS	BTOTAL BTOTAL	CONC. SLAB AROUND POOL 0.00	BPR 79.00
2200489 SIG	5/16/2022 5/16/2022	JETSTREAM COMMUNITIES LLC SIGN PERMIT	2601 N RICHMOND 330 - SIGNS	SHARDMANN SHARDMANN	SIGN ON RV PARK 3,000.00	SIG 55.00
2200490 PLB	5/16/2022 5/16/2022	MIDDLEBROOK, DON PLUMBING PERMIT	410 LILY LANE 900 - PLUMBING PERMITS	PSEAMANPLU PSEAMANPLU	REPLACE WATER HEATER, ELECT 0.00	PLB 30.00
2200491 DEV	5/16/2022 5/16/2022	CUEVAS, ANGEL DEVELOPMENT PERMIT	616 ABELL DEV - DEVELOPMENT PERMIT	BWHARTON P BWHARTON P	8X12 STORAGE BUILDING 0.00	DEV 50.00
2200492 BPC	5/16/2022 5/16/2022	BAIRD, RUSSELL BUILDING COMM. PERMIT	102 N POLK 435A - COMMERCIAL REMODELS	BACCESS CO BACCESS CO	REAR EXTERIOR BALCONY & STA 23,000.00	BPC 184.00
2200493 PLB	5/16/2022 5/16/2022	COATS, KRISTEN PLUMBING PERMIT	704 N FULTON 900 - PLUMBING PERMITS	PBRITTON PBRITTON	REPIPE INTERIOR OF HOUSE/WA 0.00	PLB 35.00
2200494 BLD-ER	5/17/2022 5/17/2022	PRUETTE, PAM BUILDING (E) RESIDENTIAL	1302 BRIAR LANE 300 - BUILDING-ELECTRICAL	EGAB ELECT EGAB ELECT	REWIRE INTERIOR,BREAKER PAN 0.00	BLD-ER 95.00
2200496 BPR	5/17/2022 5/17/2022	VELASQUEZ, GUILLERMO BUILDING RESID. PERMIT	1807 FOOTE 439 - ROOFING	BWEATHER BWEATHER	REROOF W/NEW SYNTH. 30YR SH 7,533.00	BPR 57.00

PROJECTS: 0 -ZZZZZZZZZZ
 APPLIED DATES: 5/01/2022 THRU 5/31/2022
 ISSUED DATES: 0/00/0000 THRU 99/99/9999 USE SEGMENT DATES
 EXPIRE DATES: 0/00/0000 THRU 99/99/9999
 STATUS: ALL

Item-19.

PROJECT SEGMENT	ISSUE DATE SEGMENT DT	NAME DESCRIPTION	LOCATION BUILDING CODE	CONTRACTOR SEG. CONT.	DESCRIPTION VALUATION	PROJ TYPE FEE
2200497 BPR	5/17/2022 5/17/2022	MARTINEZ, JR, ANTONIO BUILDING RESID. PERMIT	620 MOUTRAY 436 - NONRESIDENTIAL ADDITI	OWNER OWNER	AE:REAR 24'X30' PATIO/STORA 0.00	BPR 263.00
2200498 DEV	5/17/2022 5/17/2022	MARTINEZ, JR, ANTONIO DEVELOPMENT PERMIT	620 MOUTRAY DEV - DEVELOPMENT PERMIT	OWNER OWNER	24'X30' REAR PATIO/STORAGE 0.00	DEV 50.00
2200499 DEM	5/17/2022 5/17/2022	BAIRD, RUSSELL DEMOLITIONS PERMIT	102 N POLK 435A - COMMERCIAL REMODELS	BSAM CORTE BSAM CORTE	DEMO DROP CEILING & WALLS 0.00	BPC 50.00
2200500 PLB	5/17/2022 5/17/2022	KUBESCH, RAY PLUMBING PERMIT	1321 KELVING WAY 900 - PLUMBING PERMITS	PBIGSTATE PBIGSTATE	GAS TEST/METER REMOVED 0.00	PLB 35.00
2200501 MOW	5/17/2022 5/17/2022	J KROSS CO INC MOWING	630 N RUSK	OWNER OWNER	WEEDY LOT 0.00	MOW 0.00
2200502 SIG	5/18/2022 5/18/2022	BURKE'S OUTLET STORES SIGN PERMIT	301 E BOLING HWY 330 - SIGNS	SAPACHE SAPACHE	SINEW WALL SIGN/FACE CHANGE 3,350.00	SIG 63.75
2200503 MEC	5/18/2022 5/18/2022	CAMPOS, ROBERT C MECHANICAL PERMIT	2104 GRAYSON 800 - MECHANICAL PERMITS	MHUNTER'S MHUNTER'S	3TON GAS FURNANCE COND. UNI 6,500.00	MEC 85.00
2200504 BPC	5/18/2022 5/18/2022	PROSPERITY BANK BUILDING COMM. PERMIT	143 W BURLESON 331 - CONCRETE APPLICATIONS	BBRANCH BBRANCH	CONCRETE REPAIR AT BANK 2,975.00	BPC 0.00
2200505 BPC	5/18/2022 5/18/2022	CITY OF WHARTON BUILDING COMM. PERMIT	S POLK/W BURLESON 331 - CONCRETE APPLICATIONS	BBRANCH BBRANCH	HANDICAP RAMP REPAIR 4,420.00	BPC 0.00
2200506 BPC	5/19/2022 5/19/2022	HESED HOUSE OF WHARTON BUILDING COMM. PERMIT	421 COLORADO A 436 - NONRESIDENTIAL ADDITI	BGULF C BGULF C	45'X64' PERGOLA 30,000.00	BPC 0.00
2200507 BPR	5/19/2022 5/19/2022	TAYLOR, DORIS BUILDING RESID. PERMIT	223 LINN 435 - RESIDENTIAL REMODELS	BSERVPROF BSERVPROF	INTERIOR REPAIRS DUE TO FIR 0.00	BPR 776.00
2200508 BLD-EC	5/19/2022 5/19/2022	JETSTREAM COMMUNITIES LLC BUILDING (E) COMMERCIAL	2601 N RICHMOND 300 - BUILDING-ELECTRICAL	EVR ELECTR EVR ELECTR	ELECT. RV SPACES - SITE WOR 250,000.00	BLD-EC 1,475.00
2200509 BPC	5/19/2022 5/19/2022	ZIPPS LIQUOR #38 BUILDING COMM. PERMIT	323 E BOLING HWY 435A - COMMERCIAL REMODELS	BLUIS HERN BLUIS HERN	DUMPSTER ENCLOSURE/3 LITE P 16,000.00	BPC 135.00
2200510 BLD-ER	5/20/2022 5/20/2022	HACIENDA SERVICES DBA CENSE BUILDING (E) RESIDENTIAL	3618 CLINE 300 - BUILDING-ELECTRICAL	EAMERICANE EAMERICANE	ELECTRICAL FOR NEW HOME 0.00	BLD-ER 110.00
2200511 BLD-ER	5/20/2022 5/20/2022	HACIENDA SERVICES DBA CENSE BUILDING (E) RESIDENTIAL	3614 CLINE 300 - BUILDING-ELECTRICAL	EAMERICANE EAMERICANE	ELECTRICAL FOR NEW HOME 0.00	BLD-ER 110.00
2200512 BLD-ER	5/20/2022 5/20/2022	HACIENDA SERVICES DBA CENSE BUILDING (E) RESIDENTIAL	3610 CLINE 300 - BUILDING-ELECTRICAL	EAMERICANE EAMERICANE	ELECTRICAL FOR NEW HOME 0.00	BLD-ER 110.00

PROJECTS: 0 -ZZZZZZZZZZ

APPLIED DATES: 5/01/2022 THRU 5/31/2022

ISSUED DATES: 0/00/0000 THRU 99/99/9999 USE SEGMENT DATES

EXPIRE DATES: 0/00/0000 THRU 99/99/9999

STATUS: ALL

Item-19.

PROJECT SEGMENT	ISSUE DATE SEGMENT DT	NAME DESCRIPTION	LOCATION BUILDING CODE	CONTRACTOR SEG. CONT.	DESCRIPTION VALUATION	PROJ TYPE FEE
2200513 BPR	5/20/2022 5/20/2022	CHAPEL CREEK INVESTMENTS LL BUILDING RESID. PERMIT	1113 COLLEGE 101 - NEW RESIDENTIAL CONST	BA2J HOLD BA2J HOLD	4792SQFT 3-STORY RESIDENCE 0.00	BPR 0.00
2200514 MEC	5/20/2022 5/20/2022	RAMIREZ, JASON MECHANICAL PERMIT	724 COTTONWOOD DR 800 - MECHANICAL PERMITS	MTOTALCOM MTOTALCOM	3TON COND., FURNANCE + DUCT 4,500.00	MEC 75.00
2200515 BPR	5/23/2022 5/23/2022	KOLACNY, ROBERT WADE BUILDING RESID. PERMIT	3515 FAIRWAY 432 - LEVELING	LATLAS LATLAS	FOUNDATION:6 INTERIOR PILIN 0.00	BPR 58.00
2200516 DEM	5/23/2022 5/23/2022	CROUCH, JUSTIN & KRISTI DEMOLITIONS PERMIT	317 W MILAM 435A - COMMERCIAL REMODELS	OWNER OWNER	DEMO:FRONT EXTERIOR OF BLDG 0.00	BPC 50.00
2200517 BPC	5/23/2022 5/23/2022	ZIPPS LIQUOR #38 BUILDING COMM. PERMIT	323 E BOLING HWY 331 - CONCRETE APPLICATIONS	BLUIS HERN BLUIS HERN	CONC. PLOT ENTRANCE 2,500.00	BPC 44.00
2200518 PLNC	5/24/2022 5/24/2022	EMERSON HEIGHTS LLC PLAN REVIEW COMMERCIAL	201 W AHL DAG PLAN - PLAN REVIEW	OWNER OWNER	PLAN REVIEW CIVIL + STRUCTU 562,900.00	PLNREV 3,306.00
2200519 PLNC	5/24/2022 5/24/2022	EMERSON HEIGHTS LLC PLAN REVIEW COMMERCIAL	522 W MILAM PLAN - PLAN REVIEW	OWNER OWNER	PLAN REVIEW CIVIL + STRUCTU 3,676,000.00	PLNREV 15,802.00
2200520 PLNC	5/24/2022 5/24/2022	EMERSON HEIGHTS LLC PLAN REVIEW COMMERCIAL	521 W MILAM PLAN - PLAN REVIEW	OWNER OWNER	PLAN REVIEW CIVIL + STRUCTU 4,450,000.00	PLNREV 18,898.00
2200521 DEM	5/24/2022 5/24/2022	SMITH, DANNIE DEMOLITIONS PERMIT	113 S RUSK 435A - COMMERCIAL REMODELS	OWNER OWNER	DEMO EXT./INT. OF BLDG 0.00	DEM 50.00
2200522 BPR	5/24/2022 5/24/2022	LULE, MARIA BUILDING RESID. PERMIT	509 SUNSET DRIVE 331 - CONCRETE APPLICATIONS	BPRO CONST BPRO CONST	CONCRETE 30 FT BY 18 FT DR 0.00	BPR 189.00
2200523 PLB	5/25/2022 5/25/2022	WHARTON ISD JR HIGH PLUMBING PERMIT	1120 N RUSK 900 - PLUMBING PERMITS	PPHIL'S PPHIL'S	PLUMBING FOR ADD./RENOVATIO 0.00	PLB 1,190.00
2200524 BPR	5/25/2022 5/25/2022	ULLMAN, LINDA BUILDING RESID. PERMIT	415 E CANEY B 439 - ROOFING	BWEATHER BWEATHER	REROOF 3,780.00	BPC 25.00
2200525 MOW	5/25/2022 5/25/2022	AVILA ETUX GLOR, ISAIS MOWING	307 N FORD	OWNER OWNER	WEEDY LOT 0.00	MOW 0.00
2200526 BPR	5/25/2022 5/25/2022	FRAUGHTON, AUSTIN BUILDING RESID. PERMIT	517 KINKAID 436 - NONRESIDENTIAL ADDITI	OWNER OWNER	240LNFT 6FT PRIVACY FENCE 0.00	BPR 72.00
2200527 PLB	5/26/2022 5/26/2022	WHARTON COUNTY SHERIFF DEPT PLUMBING PERMIT	315 E ELM 900 - PLUMBING PERMITS	PMASON PMASON	GAS TEST FOR GENERATOR 0.00	PLB 35.00
2200528 BLD-ER	5/26/2022 5/26/2022	MARTIN, THURMAN BUILDING (E) RESIDENTIAL	302 S FORD 300 - BUILDING-ELECTRICAL	EBARBEE EBARBEE	METER LOOP REPAIR DUE STORM 0.00	BLD-ER 35.00

PROJECTS: 0 -ZZZZZZZZZZ
 APPLIED DATES: 5/01/2022 THRU 5/31/2022
 ISSUED DATES: 0/00/0000 THRU 99/99/9999 USE SEGMENT DATES
 EXPIRE DATES: 0/00/0000 THRU 99/99/9999
 STATUS: ALL

Item-19.

PROJECT SEGMENT	ISSUE DATE SEGMENT DT	NAME DESCRIPTION	LOCATION BUILDING CODE	CONTRACTOR SEG. CONT.	DESCRIPTION VALUATION	PROJ TYPE FEE
2200529 BPR	5/27/2022 5/27/2022	ABBEY, CHAD BUILDING RESID. PERMIT	701 KOEHL 432 - LEVELING	OWNER OWNER	LEVEL 30 PIERS (BLOCKS) 0.00	BPR 60.00
2200530 MEC	5/31/2022 5/31/2022	WELCH, WILLIE/SUSAN MECHANICAL PERMIT	509 LAKE SHORE DRIVE 800 - MECHANICAL PERMITS	MHUNTER'S MHUNTER'S	4TON GAS SYSTEM + DUCT WORK 10,500.00	MEC 105.00
2200531 BPC	5/31/2022 5/31/2022	WHARTON ISD - HIGH SCHOOL G BUILDING COMM. PERMIT	1 TIGER AVENUE 350 - FIRE ALARM SYSTEMS	FIRETRON FIRETRON	GYM RENOVATION:FIRE ALARM 25,000.00	ALM 247.50
2200532 MEC	5/31/2022 5/31/2022	CANEY CREEK CHURCH MECHANICAL PERMIT	118 W MILAM 800 - MECHANICAL PERMITS	MSTRONG MSTRONG	(2) 5-TON ELECT. SYS.+DUCT 17,000.00	MEC 135.00
2200533 DEM	5/31/2022 5/31/2022	WISNIESKI, SAMMY DEMOLITIONS PERMIT	1511 E BOLING HWY 645 - RESIDENTIAL STRUCTURE	DPETROSKY DPETROSKY	DEMOLITION 2-STORY RESIDENC 0.00	DEM 50.00
*** TOTALS ***		NUMBER OF PROJECTS: 101		VALUATION:	9,528,689.00 FEES:	50,209.18

PROJECTS: 0 -ZZZZZZZZZZ
 APPLIED DATES: 5/01/2022 THRU 5/31/2022
 ISSUED DATES: 0/00/0000 THRU 99/99/9999 USE SEGMENT DATES
 EXPIRE DATES: 0/00/0000 THRU 99/99/9999
 STATUS: ALL

Item-19.

*** SEGMENT RECAP ***

PROJECT SEGMENT - DESCRIPTION	# OF SEGMENTS	VALUATION	FEE
BLD-EC - BUILDING (E) COMMERCIAL	5	414,611.00	2,655.28
BLD-ER - BUILDING (E) RESIDENTIAL	7	7,950.00	670.00
BPC - BUILDING COMM. PERMIT AL	10	126,595.00	840.50
BPR - BUILDING RESID. PERMIT AL	18	11,313.00	2,628.37
DEM - DEMOLITIONS PERMIT AL	5	1,200.00	250.00
DEV - DEVELOPMENT PERMIT AL	3	0.00	150.00
MEC - MECHANICAL PERMIT AL	24	213,270.00	2,290.00
MOW - MOWING AL	5	0.00	0.00
PLB - PLUMBING PERMIT AL	17	35,500.00	2,235.00
PLNC - PLAN REVIEW COMMERCIAL L	4	8,711,900.00	38,052.00
PLNR - PLAN REVIEW RESIDENTIAL L	1	0.00	319.28
SIG - SIGN PERMIT L	2	6,350.00	118.75
*** TOTALS ***	101	9,528,689.00	50,209.18

PROJECTS: 0 -ZZZZZZZZZZ
 APPLIED DATES: 5/01/2022 THRU 5/31/2022
 ISSUED DATES: 0/00/0000 THRU 99/99/9999 USE SEGMENT DATES
 EXPIRE DATES: 0/00/0000 THRU 99/99/9999
 STATUS: ALL

Item-19.

*** BUILDING CODE RECAP ***

BUILDING CODE - DESCRIPTION	# OF PROJECTS	# OF SEGMENTS	VALUATION	FEES
BLANK - *BLANK*	5	5	0.00	0.00
101 - NEW RESIDENTIAL CONSTRUCTION	1	1	0.00	0.00
300 - BUILDING-ELECTRICAL	12	12	422,561.00	3,325.28
330 - SIGNS	2	2	6,350.00	118.75
331 - CONCRETE APPLICATIONS	6	6	10,695.00	342.00
350 - FIRE ALARM SYSTEMS	1	1	25,000.00	247.50
432 - LEVELING	2	2	0.00	118.00
435 - RESIDENTIAL REMODELS	2	2	0.00	1,242.54
435A - COMMERCIAL REMODELS	7	7	60,900.00	669.00
436 - NONRESIDENTIAL ADDITIONS	4	4	30,000.00	432.83
439 - ROOFING	6	6	11,313.00	357.00
442 - NONRESIDENTIAL ACCESSORY BUILDINGS	2	2	0.00	210.00
600 - DEMOLITIONS AND RAZING OF BUILDINGS	1	1	1,200.00	50.00
645 - RESIDENTIAL STRUCTURE DEMOLITION	1	1	0.00	50.00
800 - MECHANICAL PERMITS	24	24	213,270.00	2,290.00
900 - PLUMBING PERMITS	17	17	35,500.00	2,235.00
DEV - DEVELOPMENT PERMIT	3	3	0.00	150.00
PLAN - PLAN REVIEW	5	5	8,711,900.00	38,371.28
*** TOTALS ***	101	101	9,528,689.00	50,209.18

**Monthly Report
May-22**

Room	Rentals	Amount	YTD
Main Hall	6	\$ 5,165.00	\$ 24,324.00
Pre-Function		\$ -	\$ 640.00
O'Quinn	11	\$ 860.00	\$ 5,709.00
MTG A	1	\$ 75.00	\$ 1,100.00
MTG B	0	\$ -	\$ -
Duncan	4	\$ 355.00	\$ 2,535.00
Total	22	\$ 6,455.00	\$ 34,308.00

Room Rentals

Date	Room	Organization	Fee
5/1/2022	Main Hall	Gita Hajari	\$ 500.00
5/3/2022	Duncan	Pilot Club	\$ 75.00
5/4/2022	O'Quinn	Rotary	\$ 120.00
5/7/2022	Main Hall	Shadavia Woodard	\$ 1,000.00
5/7/2022	O'Quinn	Leah King	\$ 160.00
5/10/2022	Duncan	Pilot Club	\$ -
5/10/2022	Main Hall	Awards Banquet	\$ 775.00
5/11/2022	O'Quinn	Rotary	\$ -
5/14/2022	Main Hall	Regina Fernandez	\$ 1,000.00
5/14/2022	Duncan	Wharton Little League	\$ 140.00
5/17/2022	O'Quinn	Accent Health	\$ 135.00
5/18/2022	O'Quinn	Rotary	\$ -
5/19/2022	MTGA	DNA	\$ 75.00
5/20/2022	Main Hall	Pro Grad WISD	\$ 700.00
5/21/2022	O'Quinn	Lori Mata	\$ 160.00
5/21/2022	Duncan	Marilyn Johnson	\$ 140.00
5/23/2022	O'Quinn	Historical Commission	\$ 50.00
5/24/2022	O'Quinn	Pilot Club	\$ -
5/25/2022	O'Quinn	Rotary	\$ -
5/26/2022	O'Quinn	El Campo Memorial Seniors Pro.	\$ 75.00
5/28/2022	Main Hall	Marly Diaz	\$ 1,190.00
5/28/2022	O'Quinn	Chanell Bryant	\$ 160.00
			\$ 6,455.00



City of Wharton

Office of Emergency Management

1407 N. Richmond Rd., Wharton, TX 77488

Phone (979) 532-4811 x 502 Fax (979)532-1800

Date: April 27, 2022

To: Mr. Joseph Pace

Projects for May:

Continuing to work on updating NIMS training for all city employees (Police all done, still needing EMS 5, Fire 10, Public Works 15, City Hall 1 part time)

Still waiting on re-scheduled date for ICS NIMS 400. Waiting to hear from Instructors Rodney Grimmer and Gregory Babst from Ft Bend OEM.

Restoration City from Hungerford, has reached out and wanting to schedule an Active Shooter Presentation in May. Received great feedback from WCJC Dorm Students on the Active Shooter Presentation on the 19th.

Created an IAP for the 4th Annual Cops & Rodders Car Show on April 30, 2022 at the Civic Center.

Coordinated with the Monterey Square Business Association and created an IAP (Logistics and a traffic plan) for their 1st Annual Jam Festival on the square May 14, 2022 3pm to 7pm.

Submitted monthly reports to TxDot for the yearlong Comprehensive Traffic Grant for March.

Also completed and submitted to TX Dot the yearlong Comprehensive Traffic Grant for, 2023.

Submitted to TX Dot the Click It or Ticket Step Grant (May 23, 2022 - June 5, 2022, Memorial Day Holidays)

Always tracking and monitoring possible severe weather information from the National Weather Service.

Have scheduled a meeting with Paul Stevens with Texas Division of Emergency Management Regional Disaster Finance Coordinator for Region 2 on April 29th.

Have scheduled a meeting with Robert Saunders with Texas Division of Emergency Management Preparedness Coordinator/Planner for Region 2 on May 3rd.

Coordinating with Wharton County OEM to program all of the Police, Fire and EMS new Mobile and Portable radios, (waiting to hear back from Harris County Radio for the Code Plugs)

Attended the Mid Coast Hurricane & Disaster Conference in Victoria, Tx. last month (19 Named storms, 9 Hurricanes, 4 Major Hurricanes).

Completed ICS 2200 training and registered to attend the ICS 2300 class in Rosenberg on May 23, 24 and 25.

Have registered to attend the 2022 TDEM Conference in San Antonio May 31 thru June 3, 2022.

Plans for setting up the EOC room with city personnel on May 26, 2022 at 1pm. (to make sure SOPS are updated and everything is functional).

Bailiff duties for Wharton Municipal Court on May 11, 18 and 20 starting at 2pm.

Lt. Ben Guanajuato

**CITY OF WHARTON
ESD 3 RESPONSE REPORT
FISCAL YEAR 2020-21 COMPARED WITH 2021-22**

Month of Service	Resp Per mon	Emerg Resp	Non Emerg	No Loads	Transfers	911 OUCH	911 OBW	Flights	
Oct-20	258	165	0	93	1	60	100	3	1-ATV/2-MVA
Nov-20	247	137	0	110	1	49	77	4	1-c/1cva/2mva
Dec-20	336	193	0	143	0	62	116	10	1-c/1cva/8mva
Jan-21	308	179	0	129	1	46	120	3	1cva/2mva
Feb-21	246	165	0	81	0	41	112	6	2cardiac/1seizures/ams/IB/Resp
Mar-21	295	163	0	132	0	38	122	2	1-MVA/1-Seizure
Apr-21	269	136	1	132	3	37	94	0	
May-21	244	136	0	108	3	49	76	4	CVA/GSW/AMS/RespDistress
Jun-21	267	158	0	109	0	57	97	2	HeadTrauma/Resp.Failure
Jul-21	274	156	0	118	0	36	115	1	MVA
Aug-21	347	202	1	144	1	49	135	7	1-CVA/3-MVA/2-TRAUMA/1-MEDICAL
Sep-21	319	184	0	135	0	46	127	4	2-MVA/1-CVA/1-AMS
Totals	3410	1974	2	1434	10	570	1291	46	

Month of Service	Resp Per mon	Emerg Resp	Non Emerg	No Loads	Transfers	911 OUCH	911 OBW	Flights	
Oct-21	315	176	0	137	2	41	126	3	2-MVA/1-GSW
Nov-21	246	141	0	105	0	33	100	2	Head Injury/Gun Shot
Dec-21	239	142	0	97	2	27	87	1	MVA
Jan-22	322	172	0	146	4	49	95	5	2MVA/2CVA/1GSW
Feb-22	281	176	0	105	2	38	129	6	GSW/MVA/ASSAULT/CVA/2TRAUMA
Mar-22	308	203	0	105	1	53	137	7	*See comment below
Apr-22	270	154	0	116	0	56	81	6	GSW/2AMS/2CVA/2FALLS
May-22	282	153	0	129	0	52	86	10	*See comment below
Jun-22									
Jul-22									
Aug-22									
Sep-22									
Totals	2263	1317	0	940	11	349	841	40	

38 more calls than last year. 17 more emergent responses: last year 3 less no loads

MAR-22: 2 MVA/2 CARDIAC/1 FALL/1 CRUSH INJURY/1 SUICIDE ATTEMPT

*MAY-22: 1TRAUMA/2MVA/2CVA/2AM/S2CARDIAC/1SHOCK

Yearly Totals Mon. Avg. Mon. Avg.

2000/01	2760	230	2011/2012	3364	280
2001/02	2491	207	2012-2013	3253	271
2002/03	2688	224	2013-2014	3326	277
2003/04	2784	232	2014-2015	3770	314
2004/05	2444	203	2015-2016	3545	295
2005/06	2874	239	2016-2017	3490	291
2006/07	2928	244	2017-2018	3248	270
2007/08	3309	275	2018-2019	3244	270
2008/09	3425	285	2019-2020	3211	268
2009/2010	3205	267	2020-2021	3410	284
2010/2011	3208	267	2021-2022	2263	283

bjimenez@cityofwharton.com

From: Robert Baker <rbaker@cityofwharton.com>
Sent: Wednesday, June 22, 2022 4:54 PM
To: Brandi
Subject: June report

Council Report
June 2022

Routine Maintenance of City Parks
Routine Maintenance of City swimming Pool
Cleared courtyard at Civic Center
Removed trees, shrubs, etc.
Cleared overgrowth at Civic Center corner of University and Fulton
Removed sign post shrubs, electrical service, and tree from corner of City Hall (E. Caney at Fulton) and planted grass
Replaced rusted, leaking pipe and faucet at River Front Park pavilion
Repaired water leak in Civic Center wash room
Trimmed low limbs at City Pool walking trail
Sprayed all parks and City facilities with herbicide

Bob Baker

MAY 2022

Incident Reports By Incident Type, Summary

Page 1 of 1

Incident Type	Total Incidents:
111 Building fire	5
143 Grass fire	3
150 Outside rubbish fire, other	1
151 Outside rubbish, trash or waste fire	2
154 Dumpster or other outside trash receptacle fire	1
322 Vehicle accident with injuries	4
324 Motor vehicle accident with no injuries	7
400 Hazardous condition, other	1
411 Gasoline or other flammable liquid spill	1
444 Power line down	7
445 Arcing, shorted electrical equipment	3
551 Assist police or other governmental agency	1
561 Unauthorized burning	1
611 Dispatched & canceled en route	6
650 Steam, other gas mistaken for smoke, other	1
651 Smoke scare, odor of smoke	3
652 Steam, vapor, fog or dust thought to be smoke	1
745 Alarm system sounded, no fire - unintentional	1
746 Carbon monoxide detector activation, no CO	1
Total Number of Incidents:	50
Total Number of Incident Types:	19

Print Date: 6/3/2022



City of Wharton

120 E. Caney • Wharton, TX 77488
Phone (979) 532-2491 • Fax (979) 532-0181

MEMORANDUM

DATE: June 6, 2021
FROM: Hector Hernandez, Fire Inspector
SUBJECT: Fire Inspections for May

The Code Enforcement Department conducted the following fire inspections, plan reviews, responses, and citizen contacts in the month of April within the City of Wharton:

May:

05-03-22	New Business Walk Through	720 E Milam (1hr)
05-03-22	Zipps Liquor	323 E Boling (New Business Inspection 1hr)
05-03-22	Cyber Security Training	.5 hrs
05-03-22	Fire Call	1506 N Alabama (1hr)
05-03-22	Rescue Call	Vehicle Accident with extrication (2hr)
05-03-22	Sissy Lou's	606 N Richmond RD #A (New Business 1hr)
05-03-22	Office	work on monthly report (1hr)
05-04-22	Office	work on Open records request (.5)
05-04-22	H243	243 W Milam (Annual Inspection .5hr)
05-04-22	Beltone Hearing	241 W Milam (Annual Inspection .5hr)
05-04-22	Kapeesh Marketing	247 W Milam (Annual Inspection .5hr)
05-10-22	Civic Center	Meeting with Ms Monroe about gun show (1hr)
05-10-22	Fire wall inspection	202 E Boling Hwy (1hr)
05-10-22	Office	Prepare inspections for next duty day (1.5 hr)
05-10-22	Rescue Call	MVA (1hr)
05-10-22	Hazmat Call	Gas Leak (1.5hr)
05-12-22	Office	Phone calls (1.5 hrs)
05-12-22	Hair on the Square	212 W Milam (Annual inspection .5hr)
05-12-22	Razzmatazz	224 W Milam (Annual inspection .5hr)
05-12-22	Mattress Discounters	204 W Milam (Annual inspection .5hr)
05-12-22	Bremser Insurance	211 W Milam (Annual inspection .5hr)
05-12-22	Texas Chick	238 W Milam (New business Walk through .75hr)
05-12-22	Rescue Call	MVA (1hr)
05-12-22	Fire Call	Fire Alarm (1.5hr)
05-12-22	Fire Call	Smoke Scare (1.75hr)
05-13-22	Texas Chick	238 W Milam (CO Inspection .5hr)
05-13-22	J&T Antiques	232 W Milam (pre inspection .5hr)
05-13-22	Plan Review	Start Plan Review (Alamo Lumber .5hr)
05-13-22	Plaza Theater	120 S Houston (Walk through .5hrs)
05-26-22	Plan Review	Complete Plan Review (Alamo Lumber 1.5hr)
05-26-22	Plan Review	Started Fire Alarm Plan Review (WHS G

05-26-22

WHS

Walk through construction site (WHS Gym

Item-19.

05-26-22

Plan Review

Completed plan review (WHS Gym 1hr)

05-26-22

Post Incident

1930 Briar Ln (Post Incident Inspection .5hr)

PAUL WEBB, P.C.
 ATTORNEYS AT LAW
 221 NORTH HOUSTON STREET
 WHARTON, TEXAS 77488

PAUL WEBB
 VINCENT L. MARABLE III
 AMY ROD *

TELEPHONE: 532-5331
 AREA CODE 979
 FACSIMILE: 532-2902

* BOARD CERTIFIED - FAMILY LAW
 TEXAS BOARD OF LEGAL SPECIALIZATION

May 31, 2022

City of Wharton
 120 E. Caney
 Wharton, Texas 77488

CenterPoint Energy / Rate Increase

05/16 Three e-mails from Al Herrera and review of same;

City Council

05/09 Four e-mails of the agenda and review of same; Trip to City Hall and attend Council meeting;
 05/12 Four e-mails of 05/16/22 meeting and review of same;
 05/16 One e-mail from Paula Favors; One e-mail to Paula Favors; Trip to City Hall and attend Council meeting;
 05/18 Letter to Councilman Larry Pittman; Telephone conference with Brandi Jimenez;
 05/19 Four e-mails of Agenda for the 23rd meeting and review of same;
 05/23 Review of Agenda; Trip to City Hall and attend Council meeting;

Code Enforcement

05/02 Review letter regarding suspension of permit;

Compute North

05/02 Telephone conference with Tom Ferry;
 05/03 Telephone conference with County Judge; Telephone conference with Tom Ferry; One e-mail to Joseph Pace and Joan Anandel;
 05/04 Telephone conference with Joan Anandel; One e-mail from City Manager;
 05/10 Telephone conference with Joan Anandel; Telephone conference with Tom Ferry with Compute North; Conference with City Manager; Telephone conference with Finance Director;
 05/11 Conference with Chief Appraiser at Wharton CAD; Office conference with Compute North attorney; Telephone conference with Joan Anandel;

Haywood Ross

05/02 Pleadings filed by Plaintiff and review of same;
 05/17 Telephone conference with Paula Favors;
 05/19 Telephone conference with Paula Favors;
 05/24 Five e-mails of Dismissal and review of same;

RECEIVED
 JUN 02 2022

BY: *Bp*

Housing

05/23 One e-mail to Joe Pace, City Manager; One e-mail from Joe Pace; Trip to City Hall for housing meeting;

Liens & Tax Sales

05/04 Telephone conference with Sandra Kachmar at Mid-Coast Title regarding Ad Valorem tax lien sales;
05/18 Conference with Sandra Kachmar at Mid-Coast Title regarding liens and tax sales and results of those sales on the liens;

Municipal Court

05/04 Telephone conference with Kimberly Mahew;
05/10 Attend city pre-trials;
05/11 Review docket; Sign dismissals; Conference regarding dismissal of tickets; Conduct city trials;
05/16 E-mail regarding defendant Chaz Hayes;
05/17 E-mail regarding Chaz Hayes; E-mail regarding Kimberly Mahew; E-mail regarding Robert Walker;

Russell Baird / Water

05/16 One e-mail to Russ Baird;

Wilson / Tree

05/10 Trip to City Hall; Conference with City Manager and Public Works Director; Letter to Philip Hundl with copy to City Manager;
05/18 Review of Anthony's outline of problems and moving forward;

Attorney Fees

(1)	Amy Rod	5.25	hrs. @ \$175.00 per hour =	918.75
(2)	Paul Webb	15.00	hrs. @ \$175.00 per hour =	2,625.00
(3)	Tripp Marable		hrs. @ \$175.00 per hour =	-0-
(4)	Audra Smith		hrs. @ \$175.00 per hour =	-0-
Total Attorneys Fees				3,543.75

Expenses:

Facsimile	pages @ .75 each	
Xerox	copies @ .10 each	
E-Mail	26 pages @ .25 each	6.50
Total Expenses		6.50

Previous Balance 2,891.25
Payment Received - 05/16/22 -2,891.25

TOTAL INVOICE DUE 3,550.25



City of Wharton

120 E. Caney Street ° Wharton, TX 77488
Phone (979) 532-2491° Fax (979) 532-0181

MEMORANDUM

Date: June 2, 2022
From: Paula Favors, City Secretary
To: Joseph R. Pace, City Manager
Subject: Wharton Municipal Court Monthly Report

Please find attached the monthly report for Wharton Municipal Court for the month of May 2022.

If you have any questions, please contact Paula Favors at (979) 532-2491 Ext. 225. Thank you.

City of Wharton Municipal Court Monthly Report

Item-19.

Description	Code	Amount	G/L Acct	Oct-21	Nov-21	Dec-21	Jan-22	Feb-22	Mar-22	Apr-22	May-22
Administration Fee	AF	\$10.00	3462	\$ 20.00	\$ 40.00		\$ 10.00	\$ 30.00	\$ 50.00	\$ 80.00	\$ 60.00
Arrest Fee	AR	\$5.00	3466	\$ 420.64	\$ 608.29	\$ 670.46	\$ 617.65	\$ 638.29	\$ 976.97	\$ 718.43	\$ 755.87
Administration Fee	AF2	\$20.00	3462	\$ 140.00	\$ 140.00	\$ 340.00	\$ 240.00	\$ 320.00	\$ 400.00	\$ 420.00	\$ 260.00
Court Technology Fund	CTF	\$4.00	13 3850	\$ 142.08	\$ 76.00	\$ 64.62	\$ 63.49	\$ 182.79	\$ 183.10	\$ 60.36	\$ 92.00
Driving Safety Course Administrative Fee	DSC	\$10.00	3453	\$ 60.00	\$ 160.00	\$ 290.00	\$ 140.00	\$ 180.00	\$ 280.00	\$ 150.00	\$ 250.00
Indigent Defense Fee	IDF	\$2.00	2050	\$ 58.22	\$ 30.00	\$ 28.30	\$ 27.75	\$ 67.39	\$ 76.53	\$ 23.61	\$ 32.00
State Traffic Fee & STF 19	STF - 5% SF	\$30.00	2050	\$ 2,056.44	\$ 3,372.31	\$ 3,710.73	\$ 2,938.53	\$ 3,122.43	\$ 5,360.93	\$ 3,800.27	\$ 3,895.64
School Crossing Guard Program	CS	\$20.00	3467								
Traffic Fee City	TFC	\$3.00	3471	\$ 132.61	\$ 205.94	\$ 228.40	\$ 186.99	\$ 199.34	\$ 343.53	\$ 232.24	\$ 244.52
Child Safety	CS-2	\$25.00	3467	\$ 106.76	\$ 148.90	\$ 75.00	\$ 75.00	\$ 93.87	\$ 281.49	\$ 100.00	\$ 180.19
Fine	FINE		3450	\$ 10,772.65	\$ 13,752.75	\$ 13,293.25	\$ 11,341.17	\$ 12,981.70	\$ 18,488.98	\$ 15,776.33	\$ 15,702.35
Judicial Fee City	JFCI	\$0.60	3462	\$ 17.47	\$ 9.00	\$ 8.50	\$ 8.32	\$ 20.22	\$ 22.96	\$ 7.08	\$ 9.60
Municipal Court Building Security	MCBS	\$3.00	19 3850	\$ 87.32	\$ 45.00	\$ 42.47	\$ 41.62	\$ 101.10	\$ 114.81	\$ 35.41	\$ 48.00
State Jury Fee	SJRF	\$4.00	2050	\$ 116.43	\$ 60.00	\$ 56.62	\$ 55.49	\$ 134.79	\$ 153.09	\$ 47.21	\$ 64.00
Time Payment Plan Local	TP-L	\$10.00	3448	\$ 20.00	\$ 10.00	\$ 40.00	\$ 10.00		\$ 40.00	\$ 10.00	\$ 10.00
Time Payment Plan State	TP-S	\$12.50	2050	\$ 25.00	\$ 12.50	\$ 50.00	\$ 12.50		\$ 50.00	\$ 12.50	\$ 12.50
Administration Fee	ADMIN	\$10.00	3462	\$ 970.40	\$ 2.00	\$ 1,471.40	\$ 1,078.60	\$ 258.80	\$ 1,755.30	\$ 646.60	\$ 1,028.60
Consolidated Costs	CC04	\$40.00	2050	\$ 1,164.25	\$ 600.00	\$ 566.14	\$ 554.86	\$ 1,347.90	\$ 1,530.81	\$ 472.14	\$ 640.00
Judicial Fee State	JFCT2	\$5.40	2050	\$ 157.18	\$ 81.00	\$ 76.43	\$ 74.91	\$ 181.97	\$ 206.66	\$ 63.74	\$ 86.40
Time Payment Fee Local	TP-L-E	\$2.50	3449	\$ 5.00	\$ 2.50	\$ 10.00	\$ 2.50		\$ 10.00	\$ 2.50	\$ 2.50
Warrant Fee	WRNTFE	\$50.00	3462	\$ 1,345.06	\$ 926.79	\$ 1,837.38	\$ 861.46	\$ 2,388.34	\$ 3,672.86	\$ 1,901.02	\$ 1,832.32
Over Payment	OV		3462								\$ 0.03
Collection Agency Fee	COLAGY		2058	\$ 1,944.74	\$ 895.31	\$ 1,519.34	\$ 978.21	\$ 3,386.66	\$ 4,243.46	\$ 1,805.29	\$ 1,956.79
Judicial Fee State	JFCT	\$3.40	2050								
State Jury Fee	FEE	\$4.00	2050								
State Indigent Fee	ST-IDF	\$2.00	2050								
Corrections Management Inst.	CMI	\$0.50	2053								
Comp to Victims of Crime Fund	CVC	\$15.00	2050								
Juvenile Delinquency	JCD2	\$0.50	2050								
Consolidated Court Costs	CCC	\$17.00	2050								
Judicial Training	JCPT2	\$2.00	2050								
Civil Justice Fee State - MVF	CJFS	\$0.09	2050	\$ 0.54	\$ 0.45	\$ 0.39	\$ 0.54	\$ 0.69	\$ 1.59	\$ 0.09	\$ 0.18
Civil Justice Fee Court - MVF	CJFC	\$0.01	462 - 2050	\$ 0.06	\$ 0.05	\$ 0.04	\$ 0.06	\$ 0.08	\$ 0.17	\$ 0.01	\$ 0.02
Fugitive Apprehension	FA	\$5.00	2050								
Child Safety Seat	CSS	\$0.15	2050								
Texas Seat Belt - Children	TXSBLT	50%	2055	\$ 151.35	\$ 50.45				\$ 252.25	\$ 150.90	
Truancy Prevention Fund	TPF	\$2.00		\$ 58.22	\$ 26.00	\$ 24.30	\$ 27.75	\$ 57.38	\$ 74.10	\$ 19.63	\$ 24.00
Restitution	RST										
FTA Program - State	TLFTA1	\$20.00	10 2050	\$ 140.00	\$ 200.00	\$ 140.00	\$ 180.00	\$ 460.00	\$ 380.00	\$ 140	00
FTA Program - Vendor	TLFTA2	\$6.00	10 2059	\$ 66.00	\$ 114.00	\$ 108.00	\$ 124.74	\$ 192.00	\$ 276.00	\$ 198	00

City of Wharton Municipal Court Monthly Report

Description	Code	Amount	G/L Acct	Oct-21	Nov-21	Dec-21	Jan-22	Feb-22	Mar-22	Apr-22	May-22
FTA Program - City	TLFTA3	\$4.00	10 3451	\$ 44.00	\$ 76.00	\$ 72.00	\$ 83.16	\$ 128.00	\$ 184.00	\$ 132.00	\$ 80.00
Local Municipal Jury Fund	LMJF	\$0.10	2049	\$ 5.51	\$ 10.68	\$ 12.01	\$ 10.94	\$ 9.40	\$ 15.69	\$ 13.20	\$ 13.73
Time Payment Reimbursement Fee	TPRF	\$15.00	3448	\$ 360.00	\$ 45.00	\$ 135.00	\$ 105.00	\$ 185.64	\$ 127.55	\$ 165.00	\$ 174.36
CCC 2020	CCC20	\$62.00	2050	\$ 3,411.11	\$ 6,612.93	\$ 7,436.14	\$ 6,799.12	\$ 5,825.77	\$ 9,741.57	\$ 8,176.53	\$ 8,380.59
Local Court Technology Fund	LMCTF	\$4.00	13 3850	\$ 220.06	\$ 426.63	\$ 479.76	\$ 438.68	\$ 375.85	\$ 628.48	\$ 527.51	\$ 548.69
Local Truancy Prevention Fund	LTPDF	\$5.00	10 2050	\$ 275.11	\$ 533.29	\$ 599.70	\$ 548.29	\$ 469.80	\$ 785.62	\$ 659.41	\$ 685.87
Local Building Security Fund	LMCBSF	\$4.90	13 3851	\$ 269.59	\$ 522.63	\$ 587.69	\$ 537.34	\$ 460.43	\$ 769.88	\$ 646.20	\$ 672.14
Total				\$ 24,763.80	\$ 29,796.40	\$ 33,974.07	\$ 28,174.67	\$ 33,800.63	\$ 51,478.38	\$ 37,193.21	\$ 37,982.89
State Revenue				\$ 7,187.45	\$ 10,995.24	\$ 12,089.09	\$ 10,671.51	\$ 11,198.40	\$ 17,575.45	\$ 12,755.73	\$ 13,255.33
Less Service Fee				\$ 239.34	\$ 239.27	\$ 251.49	\$ 211.60	\$ 316.01	\$ 447.27	\$ 245.63	\$ 271.20
Total State Revenue				\$ 6,948.11	\$ 10,755.97	\$ 11,837.60	\$ 10,459.91	\$ 10,882.39	\$ 17,128.18	\$ 12,510.10	\$ 12,984.13
Monthly Separate Report											
Child Safety Seat	CSS	\$0.15	2050	\$ -	\$ -	\$ -	\$ -	\$ -	\$ -	\$ -	\$ -
Annual Separate Report											
Texas Seat Belt - Children	TXSBLT	50%	2055	\$ 151.35	\$ 50.45	\$ -	\$ -	\$ -	\$ 252.25	\$ 150.90	\$ -
City Revenue				\$ 15,414.26	\$ 17,741.40	\$ 20,257.64	\$ 16,400.21	\$ 19,023.57	\$ 29,131.22	\$ 22,283.29	\$ 22,650.77
Collection Agency - Linebargar				\$ 1,944.74	\$ 895.31	\$ 1,519.34	\$ 978.21	\$ 3,386.66	\$ 4,243.46	\$ 1,805.29	\$ 1,956.79
FTA Program - Vendor				\$ 66.00	\$ 114.00	\$ 108.00	\$ 124.74	\$ 192.00	\$ 276.00	\$ 198.00	\$ 120.00
Grand Total				\$ 24,763.80	\$ 29,796.40	\$ 33,974.07	\$ 28,174.67	\$ 33,800.63	\$ 51,478.38	\$ 37,193.21	\$ 37,982.89
Traffic Non-Parking				119	209	170	156	214	294	219	225
Parking				0	0	0	0	1	2	0	1
Non-Traffic State Law				43	21	9	62	31	76	30	24
City Ordinance				6	3	7	5	5	14	2	7
Dispositions prior to Trial				25	10	14	13	17	36	14	37
Fined				23	10	14	13	17	36	14	21
Cases Dismissed				2	0	0	0	0	0	0	0
Dispositions dismissed by Prosecution				2	0	0	0	0	0	0	16
Dispositions at Trial				311	115	125	188	120	181	139	221
Finding of Guilty				96	113	106	114	88	168	120	137
Dismissed at Trial by Prosecution				215	2	19	74	32	13	19	84
Dismissed After Driver Safety Course				13	14	16	10	12	20	9	18
Dismissed After Deferred Disposition				30	4	0	5	4	6	3	2
Dismissed After Proof of Financial Responsibility				0	1	5	2	2	0	0	0
Dismissed Compliance				9	9	19	13	18	27		0
Community Service Ordered/Completed				0	0	0	0	0	0		19

City of Wharton Municipal Court Monthly Report

Item-19.

Description	Code	Amount	G/L Acct	Oct-21	Nov-21	Dec-21	Jan-22	Feb-22	Mar-22	Apr-22	May-22
Cases Appealed				1	0	1	0	0	0	1	1
Juvenile/Minor Transportation Code Cases Filed				2	2	1	2	3	7	4	4
Juvenile/Alcoholic Beverage Code				0	0	0	0	0	0	0	0
Juvenile - Non-Traffic				0	0	0	1	0	2	0	1
Search Warrants				0	0	0	0	0	0	39	1
Arrest Warrants Issued - Class C				94	0	0	161	83	195	39	0
Arrest Warrants Issued - Felonies, Class A & B				4	6	4	6	10	14	17	8
Magistrate - Class A & B & C				0	0	0	0	0	0	0	36
Magistrate - Felonies				0	0	0	0	0	0	0	43
Magistrate - Orders for Emergency Protection				0	0	0	0	0	0	0	2

Memorandum

To: Joseph R. Pace
From: Chief Terry David Lynch
Date: 6/7/2022
Re: City Council Monthly Reports

Mr. Pace,

The attached report for the Wharton Police Department is for the month of May, for inclusion in the City Council packet.

Please contact me if you have any questions.

CONFIDENTIAL

WHARTON PD YR 2022

CATEGORY	JAN	FEB	MAR	APR	MAY	JUN	JUL	AUG	SEP	OCT	NOV	DEC	YR END TOTAL	AVERAGE PER DAY
CITATIONS	163	155	225	107	159								809	5.36
WARNINGS	177	235	208	182	156								958	6.34
CRASH REPORTS	35	21	26	26	28								136	0.90
CRIMINAL REPORTS	112	82	117	133	149								593	3.93
PATROL SECURITY CHECKS	3,968	3,381	3,066	3,928	4,466								18,809	124.56
POLICE CALLS FOR SERVICE	1,101	1,339	1,736	1,368	1,292								6,836	45.27
WEMS CALLS FOR SERVICE	183	274	286	258	272								1,273	8.43
WVFD CALLS FOR SERVICE	58	40	56	50	56								260	1.72
TOTAL CALLS FOR SERVICE-PD/FD/EMS	5,310	5,034	5,144	5,604	6,369								27,461	181.86
VICTIM ASSISTANCE CONTACTS	41	0	0	83	41								165	1.09
OPEN RECORDS REQUESTS	12	9	16	15	15								67	0.44
VISITOR LOG IN	62	43	63	45	44								257	1.70
911 CALL INTAKE	810	710	725	734	697								3,676	24.34
ANIMAL CONTROL CALLS	153	174	151	157	156								791	5.24
TAGGED JUNK VEHICLES	4	2	8	1	5								20	0.13

911 calls for May '22 were answered by WPD Telecommunicators under 10 seconds 91.54 % of the time.



City of Wharton
Public Works Department
1005 E. Milam Street ° Wharton, TX 77488
Phone (979) 532-2491 ext. 801 ° Fax (979) 531-1744

MEMORANDUM

Date: June 20, 2022
To: Joseph R. Pace, City Manager
From: Anthony Arcidiacono, Public Works Director
Subject: Public Works Monthly Report

The monthly report for the Public Works Department for May 20, 2022 through June 20, 2022 is as follows:

Streets

Asphalt all City streets
Maintenance all equipment; Completed inspections for equipment\vehicles due for the month
Mow and weed-eat all City right of ways
Street sweeper swept all City streets
Repair/Replace street and stop signs
Clean signs
Mowed at the Airport
Mowed Hwy 59 south and north
Mowed Santa Fe Ditch
Mowed Levee lots
Fleet inspections
Added more limestone to 2112 Old Lane City Rd
Mow and trim back limbs in the Milam easement between Richmond Rd and Cloud St
Delivered and spread 4 yds of limestone at 707 E. Milam
Cut back fallen tree on Camellia and Outlar
Cleaned vegetation build up on next to 305 N. Ford
Driveway inspection at 1426, 1427, 1428 and 1429 LaDelle
Cut back fallen tree at 2005 Willowbend

Drainage

Cleaned catch basins during heavy rain
Dug out ditch on Cline Drive to release dammed up water caused by contractor
Cut back ditch on Reed to improve drainage
Installed 32 ft of 15 in culvert and covered with 6 yds of limestone AT 625 Boling Green
Installing extension on culvert on Stafford to improve drainage
Installed 20 ft of 18 in culvert and covered with 4 yds of limestone at 119 Mahan
Begin construction on the driveway approach for entrance next to Santa Fe Ditch Outfall

If you have any questions, please contact me at 979-532-2491 Ext. 800. Thank you.



City of Wharton

120 E. Caney Street ° Wharton, TX 77488
Phone (979) 532-2491° Fax (979) 532-0181

MEMORANDUM

Date: June 13, 2022
From: Selena Rios, Customer Service Clerk
To: Mr. Joseph R. Pace, City Manager

Subject: May 2022 Monthly Water / Sewer Report

SEWER TREATED

Plant # 1 (S. East Ave.)	0.550	Million Gallons per Day Capacity 1.5 MGD
Plant # 2 (Highway 59)	0.240	Million Gallons per Day Capacity 0.5 MGD

DRINKING WATER PUMPED

Well # 1 (Alabama Road)	11.093	Million Gallons
Well # 2 (Cloud Street)	13.174	Million Gallons
Well # 3 (Alabama Road)	6.449	Million Gallons
Well # 4 (Valhalla Street)	10.878	Million Gallons

Re-Read & Check for Leak	11
Miscellaneous	4
Turn off for no deposit	0
OCC Chg-Read & Leave on	14
Turn off service	25
Turn on service	17
Reconnection	51
Check sewer backup	10
Water leak	8
Locate Lines	1
Meter Maintenance	5
Turn off for repairs	9
Check for leak @ meter	4
New Meter	0
Take off vacation	0
Put on vacation	1
Water/sewer taps	0
Pull Meter	0
Get reading - curr billing	5
Check for water pressure	2
Public Work Service Requests	12

Meter Information	0
Read Check after Billing	0
GRAND TOTALS	179



City of Wharton

120 E. Caney Street ° Wharton, TX 77488
Phone (979) 532-2491° Fax (979) 532-0181

MEMORANDUM

Date: June 22, 2022
From: Jimmy F. Nickolyn
To: City Manager, Joseph Pace.
Subject: Weedy Lot Report for the month of May 2022

There were 19 weedy lot letters mailed out. 12 memos were sent to mow during this time period. 31 lots were addressed during this time period.



City of Wharton

120 E. Caney Street ° Wharton, TX 77488
 Phone (979) 532-2491° Fax (979) 532-0181

MEMORANDUM

Date: June 1, 2022

From: Dwayne Pospisil, Airport

To: Joseph R. Pace, City Manager

Subject: Wharton Regional Airport Fuel Report / Fuel Inventory May 2022.

	10OLL B	10OLL T	JetA B	JetA T	Total
1	26.75				26.75
2			510		510
3		20	300	670	990
4	25				25
5		113.51	200		313.51
6		19.01	400	43	462.01
7	165.83	95.31		194.21	455.35
8	60.92	46.73			107.65
9		60	600		660
10		63.47		452	515.47
11	47.07	16.45			63.52
12	10.2	18.77	516	500	1044.97
13	45.1	18.97	540		604.07
14	128.6	134.58	240		503.18
15		25.64			25.64
16	76.86	271.61	4	73	425.47
17	50.07	73.72		119	242.79
18	39.41	19.55	98	137.3	294.26
19	19.52		351	100	470.52
20				54	54
21	35.15				35.15
22	51.54	21.47	50		123.01
23	15.94			200	215.94
24	49.18			840	889.18
25	58.02	118.42		500	676.44
26	44.66	19.64			64.3
27	12.8		300		312.8
28	44.72	17.06			61.78
29	88.91				88.91
30	23.05	25.12			48.17
31					0
Total	1119.3	1199.03	4109	3882.51	10309.84
10OLL	5,468G				
JetA	4,614G				
Truck Usage	3,262G				

City of Wharton
120 E. Caney Street
Wharton, TX 77488

CITY COUNCIL COMMUNICATION

Meeting Date:	6/27/2022	Agenda Item:	City Council may adjourn into an Executive Session in accordance with Sections 551.074 of the Local Government Code, Revised Civil Statutes of Texas. Final action, decision or vote, if any with regard to any matter considered in Executive Session shall be made in Open Meeting. Discussion: A. City Managers Evaluation.
City Manager: Joseph R. Pace		Date: Thursday, June 23, 2022	
Approval: 			
Mayor: Tim Barker			

City of Wharton
120 E. Caney Street
Wharton, TX 77488

CITY COUNCIL COMMUNICATION

Meeting Date:	6/27/2022	Agenda Item:	Action on items discussed in Executive Session: A. City Managers Evaluation.
City Manager: Joseph R. Pace		Date: Thursday, June 23, 2022	
Approval: 			
Mayor: Tim Barker			